

Revised and updated from
California State Parks Accessibility Guidelines, 2009

California State Parks

Accessibility Guidelines

2015 Edition



Accessibility Section
Acquisition and Development



Revised and updated from
California State Parks Accessibility Guidelines, 2009

California State Parks

Accessibility

Guidelines

2015 Edition



Accessibility Section
Acquisition and Development



The *Accessibility Guidelines* are intended as a reference manual and department policy on accessible design and shall be utilized in planning and implementing regular maintenance activities, construction projects, and in the development of presentations, publications, exhibits, new programs, and special events. The guidelines are not a comprehensive set of requirements for all situations, but rather a summary of information from many sources which provide guidance for common uses in the State Park System. The Accessibility Guidelines are authorized for use throughout California State Parks, including the Off Highway Motor Vehicle Recreation Division, the Division of Boating and Waterways, concessionaires, cooperating associations, and locally operated parks.

These guidelines are not a substitute for legal advice. Any specific legal issues or problems should be referred to legal counsel.

California State Parks takes **NO RESPONSIBILITY** for reliance upon these guidelines by any person or entity. All persons and entities should independently confirm standards, recommendations, laws, and regulations related to accessibility.

This publication is available in digital format at www.parks.ca.gov. To request an alternate format, please contact the Accessibility Section at (916) 445-8949. (711, TTY Relay Service)

Table of Contents

Introduction	Page i
Department Policy and Practices	Page v
Building Blocks for an Accessible Park	Page ix
Project Review Process	Page xiii
Section 0.1 Accessibility Basics	Page 1
Section 1 Alarm Systems	Page 13
Section 2 Assistive Listening Systems	Page 15
Section 3 Audiovisual Programs	Page 17
Section 4 Bathing Facilities	Page 25
Section 5 Beaches and Shores	Page 39
Section 6 Boating	Page 45
Section 7 Buildings	Page 53
Section 8 Campfire Centers & Assembly Areas	Page 61
Section 9 Camping	Page 67
Section 10 Concessions	Page 79
Section 11 Curb Ramps	Page 81
Section 12 Dining & Banquet Areas	Page 87
Section 13 Doors and Gates	Page 91

Table of Contents

Section 14	Dormitories, Hotels & Seasonal Housing -----	Page 97
Section 15	Dressing Rooms -----	Page 101
Section 16	Drinking Fountains -----	Page 105
Section 17	Equestrian Facilities -----	Page 109
Section 18	Exhibits -----	Page 111
Section 19	Fishing-----	Page 125
Section 20	Fixed Benches -----	Page 131
Section 21	Guided & Self-Guided Programs and Tours-	Page 133
Section 22	Handrails-----	Page 135
Section 23	Historic Sites-----	Page 141
Section 24	Kitchens-----	Page 149
Section 25	Lifts -----	Page 153
Section 26	Parking -----	Page 155
Section 27	Picnic Sites-----	Page 169
Section 28	Play Areas-----	Page 171
Section 29	Portable Toilets -----	Page 179
Section 30	Public Telephones-----	Page 181
Section 31	Publications -----	Page 185
Section 32	Ramps-----	Page 193
Section 33	Restrooms-----	Page 199

Table of Contents

Section 34 Routes of Travel -----	Page 211
Section 35 Service Machines -----	Page 217
Section 36 Signage -----	Page 221
Section 37 Sinks -----	Page 233
Section 38 Special Events -----	Page 235
Section 39 Stairs -----	Page 237
Section 40 Storage Areas & Lockers -----	Page 241
Section 41 Swimming Pools -----	Page 243
Section 42 Trails -----	Page 249
Section 43 Visitor Information & Sales Areas -----	Page 255
Section 44 Vista Points & Overlooks -----	Page 257
Section 45 Work Areas -----	Page 261
Glossary -----	Page 263

Appendix

Checklist for Audiovisual Programs-----	Page 277
Checklist for Exhibits -----	Page 281
Checklist for Publications-----	Page 285
Checklist for Special Events -----	Page 287

CALIFORNIA STATE PARKS ACCESSIBILITY SECTION

Guidelines for accessible design are continually changing as the Federal Access Board incorporates new and revised standards into the Americans With Disabilities Act of 1990 (ADA). California State Parks' Accessibility Section maintains these guidelines and performs review of construction projects to ensure compliance with all applicable standards. One of the primary goals of the section is to stay abreast of all laws, guidelines, and changes that affect our state parks.

To accomplish this goal, the Accessibility Section has developed the following vision and mission:

VISION

Universal accessibility is integrated into the Department's culture and embodied in its programs, providing visitors, regardless of their abilities, with high quality recreational opportunities while preserving the integrity of park resources.

MISSION

To provide direction, leadership, encouragement, and facilitation toward universal accessibility to maximize park visitor opportunities.

Introduction

The California State Parks Accessibility Guidelines (Guidelines) presents principles for providing accessibility in State Park settings. The Guidelines are intended for practical use throughout California State Parks in regular maintenance duties, construction projects, and to understand and review the work of outside contractors. Towards this end, this document is designed as a reference manual that can be used with flexibility to accommodate unique situations and settings.

The Guidelines embody a compilation of accessibility standards, recommendations, and regulations for compliance with accessibility laws. California State Parks began the process of developing the California State Park Accessibility Guidelines in the late 1980s. The first edition was published as “Access to Parks Guidelines” in 1994 and subsequent revisions have incorporated more comprehensive and up-to-date material.

Many sections of the Guidelines relate to the physical environment and serve as a resource for planners, designers, contractors, and maintenance staff. There are also sections that apply to programs and presentations that serve to inform rangers, interpreters, and volunteers. The Guidelines are the

primary tool provided by the California State Parks Accessibility Section to accomplish its mission of providing guidance in creating universal access to California State Parks.

PARK ACCESSIBILITY

Natural settings are different than urban settings. The urban environment is mostly built and can be “controlled” by design, while parks are both built and nature-based. In fact, people come to State Parks primarily to experience nature. Consequently, the built settings in the parks must be designed to fit into a natural environment without destroying the experience people come to enjoy. For this reason it is not always desirable to create settings that appear too over-built or over-designed.

The challenge for park professionals is to consider the abilities of all visitors without compromising the qualities of natural or cultural resources. The concept of individual choice based on the desired degree of challenge must also be addressed. For example, a trail through a redwood grove may be the desired experience. Some people may want a very challenging hike through the redwoods, while others just want to stroll through a beautiful natural

Introduction

setting. Therefore, unlike an urban pathway the trail is not merely a means of access to a place or activity; it is the place and type of experience visitors have that creates the “program” of that place.

Accessibility, as used throughout these guidelines, is defined as the combination of various elements in a building or outdoor area, which allows access, circulation, and full use of the building, facilities, and programs by person with disabilities. (CBC 2-202) While accessibility is a defined, prescriptive set of standards and measurements that do not change in content from setting to setting, the design challenge in park settings remains. More specifically, basic services and experiences must be accessible to visitors of all abilities, while maintaining the intrinsic qualities of the park.

PROGRAMS AND FACILITIES

The Guidelines are intended to ensure that all programs and facilities available to the public are accessible for the use and enjoyment of persons with disabilities. In the California State Parks system this shall include, but not be limited to:

- Amphitheaters & Gathering Places
- Audiovisual Programs
- Beaches & Shores

- Boating Facilities
- Cabins & Lodgings
- Camping & Picnicking
- Concessions
- Drinking Fountains
- Equestrian Facilities
- First Aid Stations
- Fishing
- Food & Dining Facilities
- Entrance Stations
- Historic Sites & Facilities
- Information Stations
- Interpretive Programs
- Living History Programs
- Marinas
- Museums
- Offices, Kiosks & Parking
- Paths & Trails
- Play Areas
- Public Transportation
- Restrooms & Bathing Facilities
- Shops & Stores
- Special Events
- Swimming Pools
- Telephones
- Visitor Centers
- Volunteer & Docent Programs

SOURCE MATERIALS

The guidelines are, in essence, a summary of the Federal and State accessibility regulations set forth by the Americans with Disabilities Act and California’s Title 24 building codes. If questions or clarifications are required beyond this document, refer to the primary source documents listed

Introduction

below, or ☎ contact the California State Parks Accessibility Section.

The four primary sources for the guidelines are:

- 2013 California Building Code (CBC) California Code of Regulations (CCR), Title 24, Part 2
- 2010 Department of Justice (DOJ) ADA Standards for Accessible Design (ADASAD)
- 2013 US Access Board (ABA) Accessibility Guidelines for Outdoor Developed Areas, 36 CFR Part 1191 (AGODA) including:
 - 1999 Regulatory Negotiation Committee on Accessibility Guidelines for Outdoor Developed Areas (99 AG)
- Section 508 of the 1973 Rehabilitation Act, amended 1998, 29 U.S.C. 794d

DEVIATION FROM GUIDELINES

These guidelines are a summary of the most current regulations and represent the accessibility standards prescribed by the Accessibility Section of California State Parks. For more information on a particular guideline or standard, the source material documents may be consulted.

California State Parks' Accessibility Section recognizes that deviations from standards may be necessary from time to time due to the environmental conditions and unique constraints of a particular site. In these cases, the Accessibility Section should be ☎ contacted for guidance and direction. For more detailed information about the project review process, refer to the Project Review Process Section on page xiii.

UPDATES

The Accessibility Section will periodically update these guidelines as regulations change. All users should send written corrections, suggested changes and additional comments to:

California State Parks
Accessibility Section
One Capitol Mall, Suite 410
Sacramento, CA 95814

The Accessibility Section is available to answer specific questions and provide technical assistance regarding issues at individual sites.

For accessibility questions or to receive this publication in an alternate format, ☎ contact the Accessibility Section at (916) 445-8949, 711, TTY RELAY SERVICE, or by email at: access@parks.ca.gov.

Department Policy and Practices

California State Parks has many policies and practices that are mandated to ensure that all citizens have access to park facilities and programs. Chapter 2600 of the Department Operations Manual provides the basis and authority for these guidelines which are intended to provide technical standards for the provision of accessible programs and facilities. For further information about the policies summarized below consult the corresponding Departmental Notice or DOM Chapter Section.

The Department's accessibility policies include:

ACCESSIBILITY POLICIES	DESCRIPTION
<p>Accessibility Program Policy DOM 2600, DN 1995-32</p>	<p>It is the policy of the Department to meet the recreational needs of all the people of California and to provide an accessible environment in which all visitors to the State Park system units are given the opportunity to understand, appreciate and participate in the State's cultural, historical and natural heritage.</p>
<p>Accessible Campsite Policy DOM 2607.8, DN 2006-05</p>	<p>It is the policy of the Department to establish consistent and uniform statewide guidelines that all park units will follow to ensure that accessible campsites are available for park visitors with disabilities, while maximizing campground occupancy.</p>
<p>Use of Qualified Sign Language Interpreters DOM 2607.5, DN 2004-07</p>	<p>It is the policy of the Department to make available appropriate auxiliary aids and services, such as a qualified sign language interpreter, when requested.</p>

Department Policy and Practices

ACCESSIBILITY POLICIES	DESCRIPTION
<p>Accessibility and Historic Properties Policy DN 2005-03</p>	<p>This Departmental Notice establishes a policy to ensure that the public access to the Department's historic properties complies with the law. Further, this notice provides standards, guidelines and the process to follow throughout the Department in order to provide compliant access while preserving historic fabric.</p>
<p>Accessibility and Publications Policy DOM 2607.3</p>	<p>It is the policy of the Department that all new or reprinted Department publications shall be prepared using the standards specified in the Department's Accessibility Guidelines.</p>
<p>Accessibility Comment / Complaint Policy DOM 2607.7, DN 2001-07</p>	<p>This policy of California State Parks is to ensure that people with disabilities are treated with dignity and respect and are free from discrimination while visiting California State Parks. The Department has established procedures to give persons with disabilities the opportunity to make comments or file discriminatory complaints against State Park System units that have not complied with the ADA.</p>
<p>Special Events Accessibility Policy DOM 2607.6</p>	<p>It is the policy of the Department that events beyond the normal scope of activities and operations be accessible to all visitors, and shall follow the standards specified in the Department's Accessibility Guidelines.</p>

Department Policy and Practices

ACCESSIBILITY POLICIES	DESCRIPTION
Service Animals Policy DOM 2607.9	It is the policy of the Department that service animals be allowed into all areas that are open to the public. Service animals are animals that are individually trained to perform tasks for persons who have qualifying disabilities under the ADA.
Beach Wheelchair Policy DOM 2607.10	It is the policy of the Department to provide beach wheelchairs in some locations free of charge for people who use wheelchairs or have other mobility disabilities. Beach wheelchairs provide access to soft sandy surfaces for people who use wheelchairs or who have other mobility disabilities.
Other Power Driven Mobility Device (OPDMD) Policy DOM 2607.11	It is the policy of the Department to permit the use of certain specified OPDMD's by persons with mobility disabilities. An OPDMD is any mobility device powered by batteries, fuel, or other engines that is used by individuals with mobility disabilities for the purpose of locomotion.
Construction Project Accessibility Review Policy DOM 2608.1	Projects that will result in physical changes to public or employee use areas shall be reviewed for compliance by the Accessibility Section. See the Project Review Process section on page xiii.

Department Policy and Practices

Following are suggested accessibility references, other than the Guidelines, that can be consulted when needed. Professional designers should consult source materials such as the most current version of the California Building Code and applicable federal standards and guidelines.

DEPARTMENTAL REFERENCES

- “All Visitors Welcome – Accessibility in Interpretive Programs and Facilities.” California State Parks.

SUGGESTED REFERENCES

- “CalDAG – California Disabled Access Guidelines” Most Recent Edition. Michael P. Gibbons.
- “2013 CBC Advisory Manual” State of California, Division of the State Architect.
- “California Historical Building Code” Most Recent Edition. California Building Standards Commission.
- “Everyone’s Welcome” American Association of Museums, 1998.
- Lighthouse International – www.lighthouse.org/accessibility.

- “Means ADA Compliance Pricing Guide” Most recent edition. Adaptive Environments Center, Inc. R.S. Means Engineering Staff.
- “Preserving the Past and Making it Accessible for People with Disabilities.” National Park Service, Cultural Resources Preservation Assistance Division, 1992.
- “Smithsonian Guidelines for Accessible Exhibition Design.” Smithsonian Institution, Office of the Provost, Accessibility Program, most recent edition.
- “Universal Access to Outdoor Recreation – A Design Guide.” PLAE, Inc., Berkeley, CA and U.S.F.S., 1993.
- “2010 ADA Standards Excerpts for Recreational Boating Facilities.” California Department of Boating and Waterways, 2013. http://dbw.parks.ca.gov/PDF/Reports/DBW_2010_ADA_Booklet-Dec_2012.pdf.

Building Blocks for an Accessible Park

The California State Parks Accessibility Guidelines cover standards for particular features in the park environment. These park features should be integrated into an overall park site plan and be considered as part of a larger planning process for accessibility. Site planning is important to the process of providing access to all programs and services that the park offers. Each site shall be planned as a whole to form a well-integrated, accessible network of facilities and programs.

The goal is to provide all visitors optimum experiences through individual choice. For example, if camping or picnic areas provide some sites in the sun, some in the shade, and some over-looking a lake, then accessible sites should be developed in each location rather than offering a limited selection. Partial accessibility does not provide for optimum experiences through individual choice.

It is Department policy (DN 95-32) that all public use facilities, furnishings, and equipment (i.e., picnic tables, fire rings, drinking fountains, chemical toilets, etc.) when purchased, leased, or rented by the Department must be of the accessible variety. In addition, new development, including modifications

to existing facilities, **MUST** be designed in accordance with these guidelines.

In the event that a park program or facility is not, or cannot be made physically accessible, parks staff must make reasonable modifications in policies, practices, and/or procedures when necessary to ensure that people with disabilities are afforded an equal opportunity to benefit from the program or activities provided.

CIRCULATION

No program or facility can function independent of its linkage to the natural, social and physical environment to which it belongs. Similarly, no program or facility can be accessible by itself. If a park provides major programs in different areas, accessible circulation must be provided to connect each of these areas, facilities and activities, rather than restricting visitors with disabilities to using only selected areas and programs.

There are three types of circulation that can provide accessibility and each must begin at a point of arrival be it a parking space, a transit stop, or pedestrian entry from the park boundary.

Building Blocks for an Accessible Park

1. Exterior Route of Travel and Accessible Route of Travel: These general terms describe a continuous, unobstructed path connecting accessible elements and spaces in a building or between exterior elements of a facility. Exterior and accessible routes are safe and usable by persons with disabilities, including pedestrians and visitors requiring the use of mobility devices. These paths or routes may include walks, sidewalks, ramps, corridors, and other such improved areas.
 - a. Exterior accessible routes may include: parking access aisles, curb ramps, crosswalks at vehicular ways, walks, ramps, and lifts.
 - b. Interior accessible routes may include: corridors, floors, ramps, elevators, lifts, and clear floor space at fixtures.
 - c. An accessible circulation path may include an exterior or interior way of passage from one place to another for pedestrians, including, but not limited to, walks, hallways, courtyards, stairways, and stair landing.
2. Outdoor Recreation Access Route: Paths that connect and provide access to elements within a picnic area, camping area, or designated trailhead.
3. Trails: Paths that provide access to a site's remote settings or that are constructed primarily for outdoor recreational purposes. Trails enhance the visitor's experience of natural and cultural features of a site, allowing varied levels of accessibility without negatively impacting the recreational activity or resources.

Parks must provide accessible circulation that connects accessible features within a park so that a visitor with a disability can enter the park, get to and utilize restrooms and facilities, and take part in the programs available (visitor center, picnic area, campgrounds, etc.).

The basic dimensions and specifications required for accessibility are provided within these Guidelines.

SPACE ALLOWANCES

When designing for all people, the spatial requirements are different from those historically used in design. Universal design takes into account the fact that people come in a variety of shapes, sizes, abilities, and ages. Therefore, when planning and designing, it is important to utilize widths, lengths, and dimensions that accommodate a wide range of people and ensure access to recreational facilities and programs for all visitors.

Building Blocks for an Accessible Park

The basic spatial dimensions necessary to accommodate people who use wheelchairs, mobility aids, or who have visual impairments form the basis of these guidelines.

Typical space allowances for accessibility that you will find throughout these guidelines include clear ground or floor space, the minimum dimensions required for an adult using a wheelchair, and the passing widths and turning requirements for that person.

REACH RANGES

The “reach range” refers to the maximum and minimum heights that a person in a wheelchair can reach in the forward and side directions. Objects that can be reached (such as exhibit buttons, telephones, Braille signs, grills, hose bibs, etc.) need to be positioned within the appropriate reach range to be accessible to people in wheelchairs. The two types of reach ranges are in the “forward” and “side” directions. In general, where reaches are required over an obstruction, such as a shelf or desktop, clear floor space must be provided under the obstruction or reach depths shall be limited to ensure access compliance.

OBSTACLES, HAZARDS, AND CLEARANCE

In recreational settings it is often desirable to retain the natural features and character of a place through aesthetically appropriate design. This must be done in a way that also provides safe maneuvering and access. To maximize clearances and minimize hazards, projections, protrusions, and gratings or openings in the clear ground or floor space need to be carefully considered.

COMMUNICATION

Physical access is only one form of access to parks. Making park programs accessible requires making communications accessible. Parks that offer visitors physical access to programs and facilities cannot be considered fully accessible unless the staff can effectively communicate with visitors with disabilities. Interpretive programs, nature walks, campfire talks, films, and other special programs should also be made available to everyone through alternative formats such as sign language, Braille, oral description, and captioning. These are described in the guidelines that follow.

Building Blocks for an Accessible Park

For additional detailed information about how to make communication accessible refer to the California State Parks document, “All Visitors Welcome – Accessibility in Interpretive Programs & Facilities” and the Department’s Qualified Sign Language Interpreters policy.

These basic building blocks for accessibility appear throughout the Guidelines and must be considered when designing or maintaining State Park settings. The sections in the Guidelines outline requirements for specific park features.

Project Review Process

The Department must incorporate accessible features when it undertakes projects that potentially alter use areas or facilities within State Parks. The Department is also mandated to track accessibility improvements. The Accessibility Section is responsible for ensuring compliance with these mandates by reviewing all projects and should be involved in the planning stages of projects that affect employee or visitor use areas to ensure that access is adequately integrated. Accessibility Section project review will also ensure that California State Parks continues to provide all visitors, regardless of their abilities, with high quality recreational opportunities, while preserving the integrity of park resources.

Consequently, all Project Evaluation Forms (PEFs) SHALL be routed to the Accessibility Section for review and approval regardless of the anticipated CEQA compliance determination. In order to ensure an accurate project description on your PEF and to avoid repetitive reviews, it is highly recommended that the accessibility review occur prior to review by other specialists. Do not assume there are no access issues involved in a project unless the Accessibility Section has exempted it because an oversight of access may cause significant delays. If your project does not require a PEF

for CEQA purposes, it may still require an accessibility review if it has the potential to alter a facility or use area.

Upon submission of the PEF, the Accessibility Section will provide the project manager with a Review and Comment Sheet, (DPR 727) which will indicate accessibility features that must be incorporated into the project. In some cases, the comment sheet will indicate that the project is exempt from accessibility requirements. The Accessibility Section makes every attempt to conduct its review and provide the comment sheet within 10 business days. Copies of the review and Comment Sheet should be kept in the official project files. PEFs can be emailed to the Accessibility Section at access@parks.ca.gov, or hard copies sent to the Section at:

California State Parks
Accessibility Section
One Capitol Mall, Suite 410
Sacramento, CA 95814

It is your responsibility to  contact the Accessibility Section when you begin work on any project, including design, planning, interpretive, engineering, trail, or construction projects. When you do, Accessibility Section Specialists will help you address legally mandated access compliance issues.

Project Review Process

ACCESSIBILITY SECTION PROJECT REVIEW PROCESS

I. PROJECT PLANNING

Planning for access for people with disabilities needs to take place at the very early stages of a project. When Project Evaluation Forms (PEF) and Concept Papers are initially drafted, that is the appropriate phase at which to have the project reviewed by the Accessibility Section. A ☎ phone call to discuss the project will allow the Accessibility Section to log the project into its database and help project managers determine the specific components that should be included in the project. The more information about the project and existing site conditions that you provide, the better the Accessibility Section specialists will be able to assist you. Site drawings, topographic maps, and photographs are quite valuable in helping to impart the details of your project, and often these same documents can be used as part of the final PEF. Early review will determine if the access features in the project have been adequately addressed and/or if subsequent reviews will be necessary.

This stage of review will also identify all issues with physical alterations required for access compliance often associated with qualified historical

properties and outdoor environments, and will prevent access issues from being overlooked or applied improperly.

II. PRELIMINARY DESIGN AND CONSTRUCTION DOCUMENTS

In addition to conceptual reviews, projects for which plans and specifications are developed will need to be reviewed at the stages of preliminary plan design, design development, and construction document preparation stages. The complexity of the project and schedule will vary. As a result, the level of completeness for the intermediate stages of preliminary plan design review submittal will vary. In general, design review submittals should take place at each of the following steps:

- 1) Schematic/preliminary design,
- 2) Design development / 30% construction documents, and
- 3) 70% completed construction documents.

III. FINAL PLAN REVIEW AND CERTIFICATION

Pursuant to the Government Code, contracted construction projects cannot

Project Review Process

be put out to bid until the plans and specifications have been certified by Accessibility Section Architects. Approved and certified construction documents must demonstrate that the project will comply with current accessibility codes, regulations, and guidelines. To that end, the Accessibility Section of California State Parks must review all final plans and specifications to ensure compliance. All approved plans will receive a certification stamp, dated and signed by a Certified Access Specialist (CAsp).

IV. POST CONSTRUCTION

An "Accessibility Verified Report" form (DPR 339) must be submitted at the completion of all construction projects. This form documents that park staff or contractors have completed the project pursuant to accessible standards. At the completion of a public works project, the project manager should notify the Accessibility Section so that a verified report can be completed and certified. District Staff can utilize the Accessibility Guidelines as a reference to prepare the verified report for small, district-led projects. Project managers shall submit a copy of the verified report to the Accessibility Section, and retain a copy in the project file.

V. TRAIL PLANNING

When planning trail projects, the following steps should be completed in order to coordinate review by the Accessibility Section and ensure compliance with current regulations and integration into the statewide accessible trail program.

- 1) ☎ Contact the Accessibility Section Trail Specialists to discuss the trail project, determine the potential level of accessibility, and evaluate the trails inclusion in the statewide accessible trail's program.
- 2) Submit a draft PEF to the Accessibility Section with a detailed project description, maps showing connections to other trails and to trailheads, and photographs.
- 3) If the Accessibility Section Trail Specialist determines that the trail qualifies for a departure from the current guidelines, a detailed explanation of the reason for this departure from the guidelines is required. Photographs and topographic maps would be helpful in supporting the reason for departure.
- 4) Trail accessibility recommendations, departures, and exceptions must be documented and kept on record as evidence of accessibility review in the project files.

Project Review Process

VI. EXHIBIT DESIGN

When new interpretive exhibits are constructed, or when existing exhibits are altered or modified, an accessibility review is required to verify that the exhibit is, or will be physically accessible. This may include but is not limited to: verifying exhibit location along an accessible route, exhibit mounting height, and to verify that buttons or controls are within proper reach ranges. Exhibit artwork, graphics, and text must conform to the requirements contained in the exhibits section of this publication but are not subject to review by the Accessibility Section.

It is important to initiate the review process prior to the completion of the exhibit design, otherwise additional design costs and delays may occur. Staff should ☎ contact the Accessibility section during the initial design planning stage.

Accessibility Basics

I. CONCEPT

- A. This Section contains criteria for what are considered “building blocks” of accessibility as established by the 2010 ADA Standards for Accessible Design (ADASAD). Included are requirements for ground and floor surfaces, changes in level, wheelchair turning space, clear floor space, knee and toe clearances, protruding objects, reach ranges, and operable parts.

II. FLOOR AND GROUND SURFACES - ADASAD 302

- A. Accessible floor and ground surfaces are stable, firm, and slip resistant.
1. A stable surface is one that remains unchanged by contaminants or applied force, so that when the contaminant or force is removed, the surface returns to its original condition.
 2. A firm surface resists deformation by either indentations or particles moving on its surface.
 3. A slip-resistant surface provides sufficient frictional counterforce to the forces exerted in walking to permit safe ambulation.
- B. Carpet or carpet tile must be securely attached and have a firm cushion, pad, or backing, or have no cushion or pad. Accessible carpet or carpet tile has a level loop, textured loop, level cut pile, or level cut/uncut pile texture. Pile height must be no more than 1/2". Exposed edges of carpet must be fastened to floor surfaces and have trim on the entire length of the exposed edge. Carpet edge trim must comply with Part III, Changes in Level below.

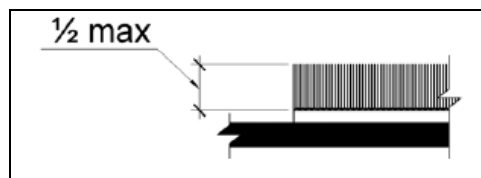

Figure 0-1 Carpet Pile Height

Section 0.1 - Accessibility Basics

- C. Openings in floor or ground surfaces must not allow passage of a sphere more than 1/2" in diameter. Elongated openings are to be placed so that the long dimension is perpendicular to the dominant direction of travel.

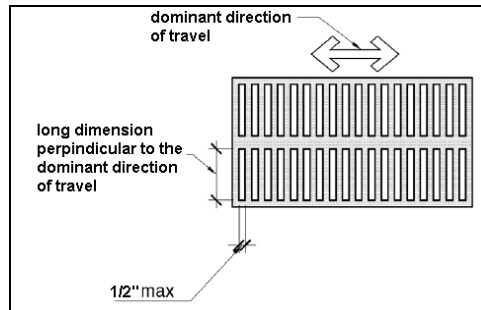

Figure 0-2 Elongated Openings in Floor or Ground Surfaces

III. CHANGES IN LEVEL - ADASAD 303

- A. Changes in ground or floor level must not exceed 1/2". Any change in level exceeding 1/2" must comply with the requirements for a ramp.
★ Refer to Section 31 - Ramps.
- B. Vertical changes in level must not exceed 1/4".

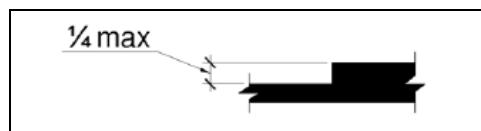

Figure 0-3 Vertical Change in Level

- C. Changes in level between 1/4" high minimum and 1/2" inch high maximum are to be beveled with a slope not steeper than 1:2.

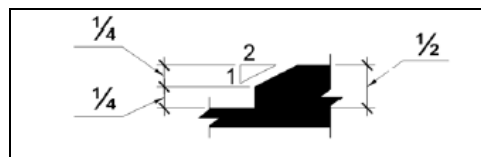

Figure 0-4 Beveled Change in Level

- D. Abrupt changes in level exceeding 4" in a vertical dimension between walks, sidewalks, or other pedestrian ways and adjacent surfaces or features shall be

Section 0.1 - Accessibility Basics

identified by warning curbs at least 6" in height above the walk or sidewalk surface.

CBC 11B-303.5

EXCEPTIONS: (1) A warning curb is not required between a walk or sidewalk and an adjacent street or driveway. (2) A warning curb is not required when a guard or handrail is provided with a guide rail centered 2" minimum and 4" maximum above the surface of the walk or sidewalk.

★ Refer to Section 22 - Handrails.

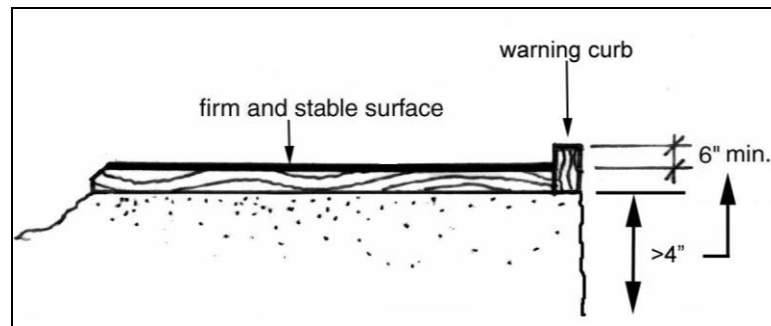

Figure 0-5 Warning Curb Height

IV. TURNING SPACE - ADASAD 304

- A. At accessible turning spaces, there must be a clear space measuring 60" in diameter or a T-intersection with aisles at least 36" wide and 60" long for turning a wheelchair around.

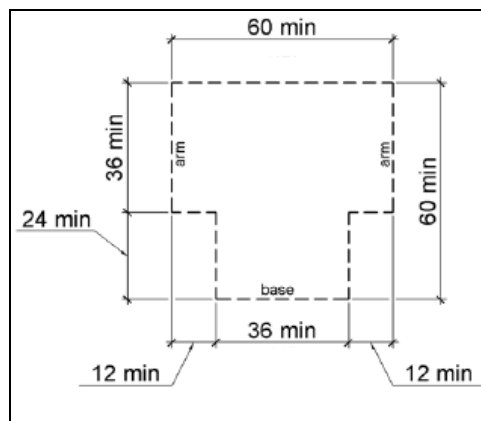

Figure 0-6 T-Shaped Turning Space

Section 0.1 - Accessibility Basics

- B. These clear spaces must be free of obstructions but may include knee and toe clearances as shown in Part VI, Knee and Toe Clearance (at the T-shaped space this is permitted only at the end of either the base or one arm).
- C. Doors are permitted to swing into these spaces.

V. CLEAR FLOOR OR GROUND SPACE - ADASAD 305

- A. Clear floor and/ground spaces are required at many accessible elements (e.g. plumbing features, counters, exhibits, etc.).
- B. Floor or ground surfaces of a clear floor or ground space must comply with Part VI, Floor and Ground Surfaces. Changes in level are not permitted. Slopes must not exceed 2%.
- C. Clear floor or ground surfaces are 30" minimum by 48" minimum.

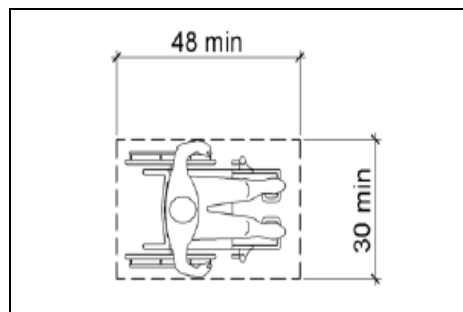

Figure 0-7 Clear Floor or Ground Space

- D. Unless otherwise specified, clear floor or ground space shall be permitted to include knee and toe clearance complying Part VI, Knee and Toe Clearance.
- E. Unless otherwise specified, clear floor or ground space shall be positioned for either forward or parallel approach to an element.

Section 0.1 - Accessibility Basics

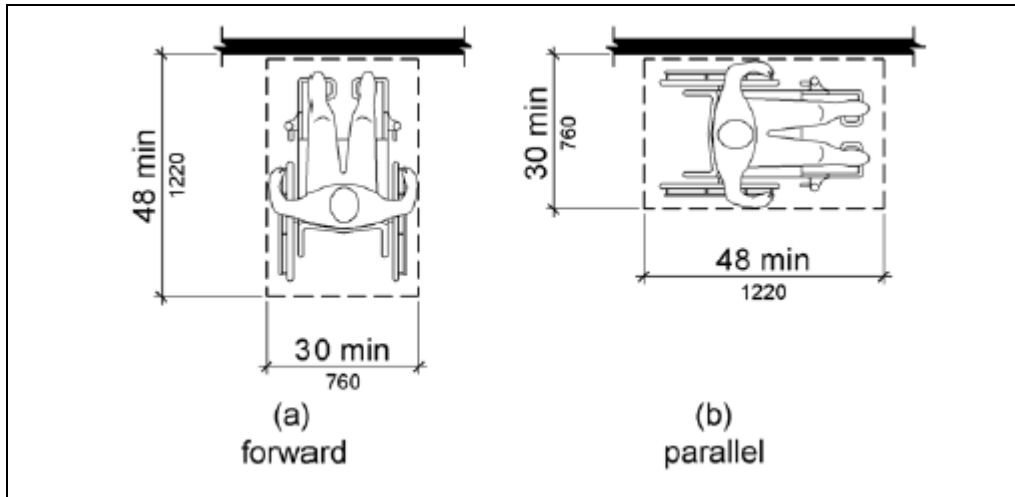

Figure 0-8 Position of Clear Floor or Ground Space

- F. One full unobstructed side of the clear floor or ground space must adjoin an accessible route or adjoin another clear floor or ground space.
- G. Where a clear floor or ground space is located in an alcove or otherwise confined on all or part of three sides, additional maneuvering clearance must be provided as follow:
 1. For a forward approach, alcoves must be 36" wide minimum when the depth exceeds 24".

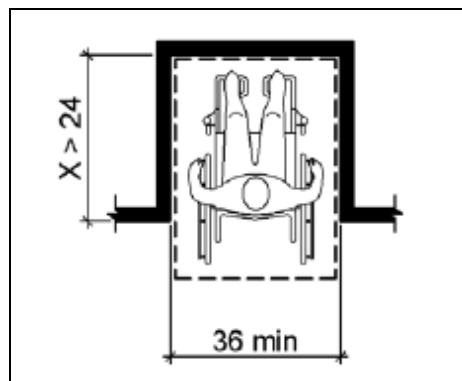

Figure 0-9 Maneuvering Clearance in an Alcove, Forward Approach

2. At a parallel approach, alcoves must be 60" wide minimum where the depth exceeds 15".

Section 0.1 - Accessibility Basics

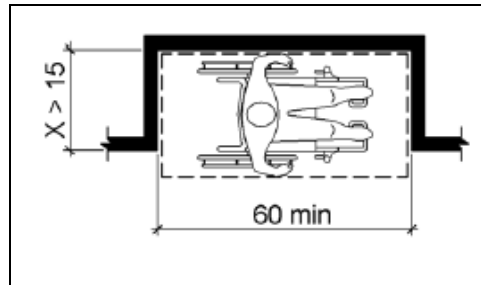

Figure 0-10 Maneuvering Clearance in an Alcove, Parallel Approach

VI. Knee and Toe Clearance - ADASAD 306

- A. Where clear floor spaces are required or permitted beneath elements, knee and toe clearance apply.
- B. Space under an element between the finish floor or ground and 9" above the finish floor or ground are considered toe clearance and comply with the following:
 1. Where toe clearance is required at an element as part of a clear floor space, the toe clearance shall extend 17" minimum under the element.

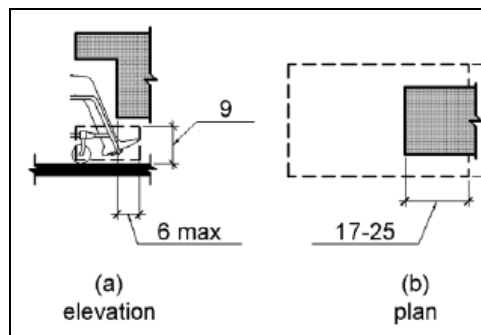

Figure 0-11 Toe Clearance

2. Space extending greater than 6" beyond the available knee clearance at 9" above the finish floor or ground is not to be considered toe clearance.
 3. The width of toe clearance is 30" wide minimum.
- C. Space under an element between 9" and 27" above the finish floor or ground are considered knee clearance and comply with the following:

Section 0.1 - Accessibility Basics

1. Where knee clearance is required at an element as part of a clear floor space, the knee clearance shall extend 11" deep minimum at 9" above the finish floor or ground, and 8" deep minimum at 27" above the finish floor or ground.

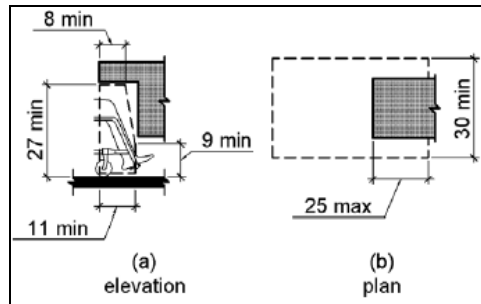

Figure 0-12 Knee Clearance

2. The width of knee clearance is 30" wide minimum.

VII. Protruding Objects - ADASAD 307

- A. Objects with leading edges more than 27" and less than 80" above the finish floor or ground cannot protrude more than 4" horizontally into the circulation path. Note: Handrails are permitted to protrude 4½" maximum.

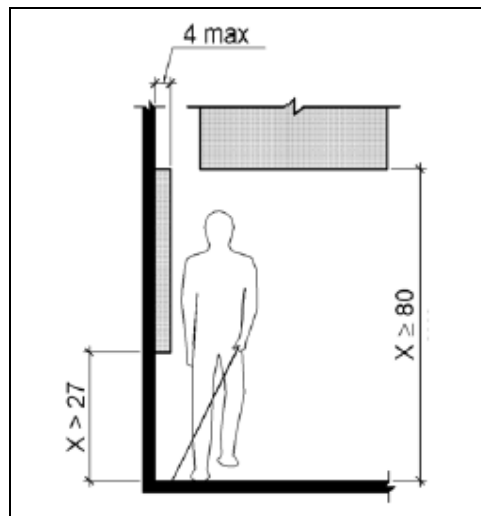

Figure 0-13 Limits of Protruding Objects

- B. Free-standing objects mounted on posts or pylons cannot overhang circulation paths more than 12" when located between 27" and 80" above the finish floor

Section 0.1 - Accessibility Basics

or ground. Where a sign or other obstruction is mounted between posts or pylons and the clear distance between the posts or pylons is greater than 12", the lowest edge of such sign or obstruction must be 27" maximum or 80" minimum above the finish floor or ground.

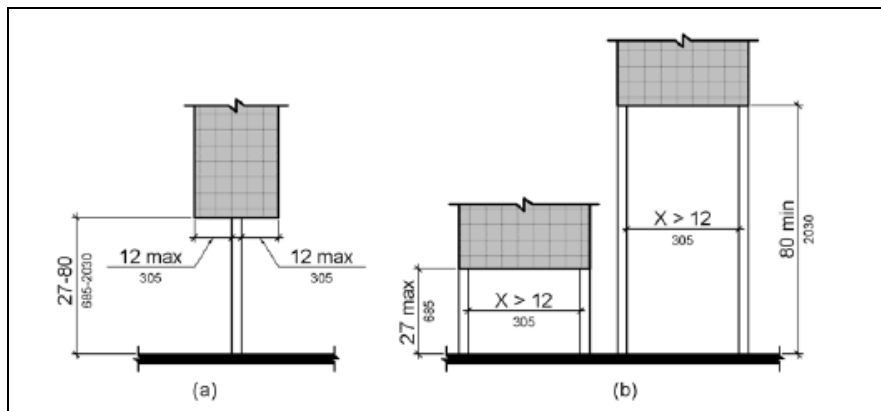

Figure 0-14 Post-Mounted Protruding Objects

- C. If there is less than 80" of clear headroom next to an accessible route, there must be a cane detectable barrier within 27" of the floor. Note: Door closers and door stops are permitted to be 78" minimum above the finish floor or ground.

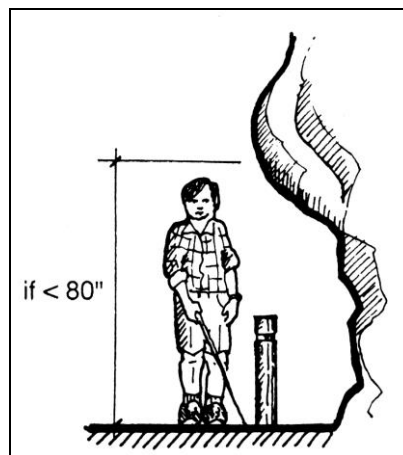

Figure 0-15 Cane Detectable Barrier

- D. Protruding objects must not reduce the clear width required for accessible routes.

Section 0.1 - Accessibility Basics

VIII. REACH RANGE - ADASAD 308

A. Forward reach ranges:

1. Where a forward reach is unobstructed, the high forward reach is 48" maximum and the low forward reach is 15" minimum above the finish floor or ground.

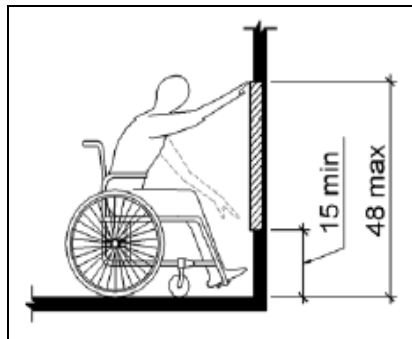

Figure 0-16 Unobstructed Forward Reach

2. Where a high forward reach is over an obstruction, the clear floor space shall extend beneath the element for a distance not less than the required reach depth over the obstruction. The high forward reach must be 48" maximum where the reach depth is 20" maximum. Where the reach depth exceeds 20", the high forward reach can be no more than 44" over a maximum depth of 25".

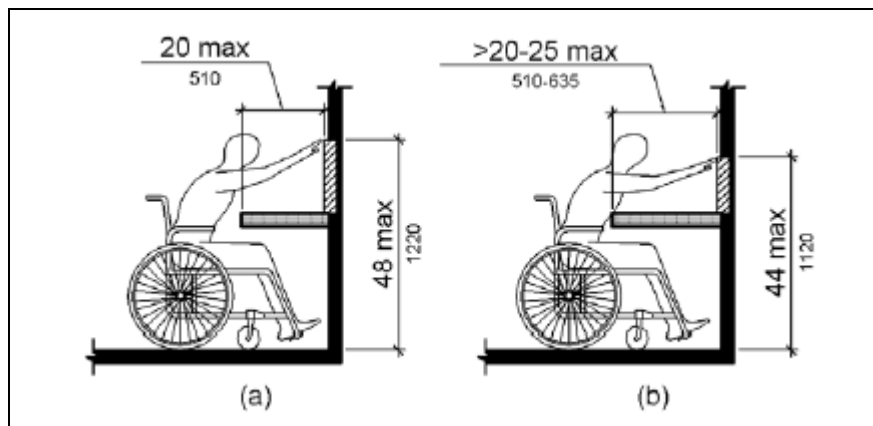

Figure 0-17 Obstructed High Forward Reach

Section 0.1 - Accessibility Basics

B. Side reach ranges:

1. Where a side reach is unobstructed, the high side reach is 48" maximum and the low side reach is 15" minimum above the finish floor or ground.

Note: An obstruction is permitted between the clear floor or ground space and the element where the depth of the obstruction is no more than 10".

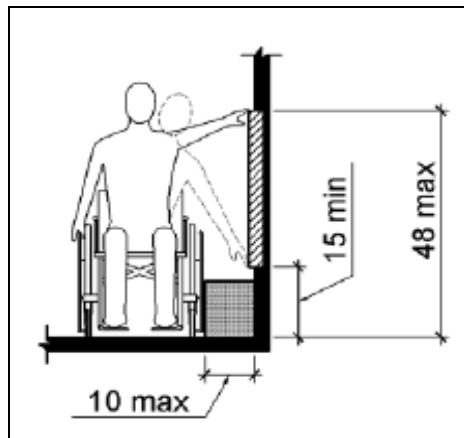

Figure 0-18 Unobstructed Side Reach

2. Where a clear floor or ground space allows a parallel approach to an element and the high side reach is over an obstruction, the height of the obstruction can be 34" maximum and the depth of the obstruction can be 24" maximum. The high side reach can be 48" maximum for a reach depth of 10" maximum. Where the reach depth exceeds 10", the high side reach can only be 46" maximum for a reach depth not to exceed 24".

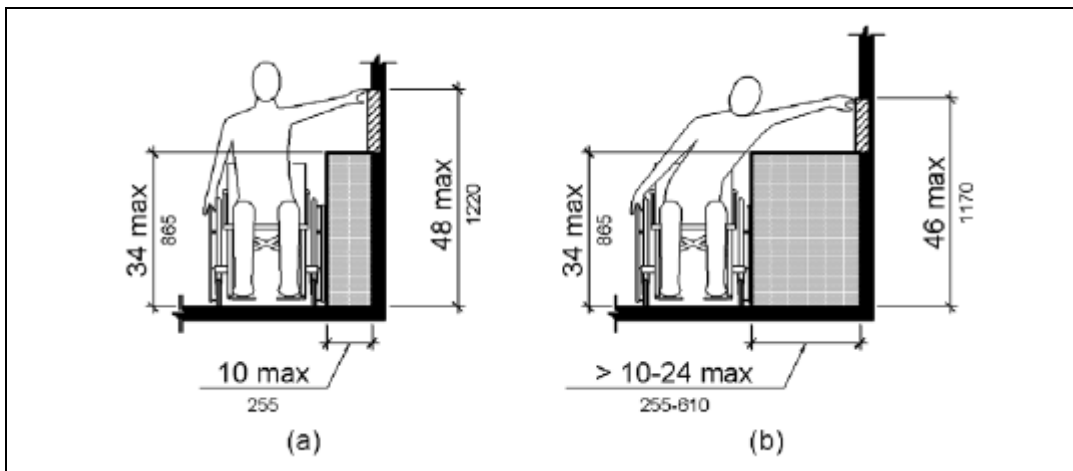

Figure 0-19 Obstructed High Side Reach

Section 0.1 - Accessibility Basics

IX. Operable Parts - ADASAD 309

- A.** A clear floor or ground space complying with Sub -Section V, Clear Floor or Ground Space, must be provided at all elements with operable parts.
- B.** Operable parts must be placed within one or more of the reach ranges specified in Part VII.
- C.** Operable parts must be operable with one hand and cannot require tight grasping, pinching, or twisting of the wrist. The force required to activate operable parts can be no more than be 5 lbs.

Alarm Systems

I. CONCEPT

- A.** Alarm systems must be accessible to people with visual and hearing impairments. The State Fire Marshal must be contacted for all existing, new, and retrofit system requirements.
- B.** For program accessibility requirements that may require visual or audible alarms absent any construction, ☎ contact the Accessibility Section.

II. GENERAL

- A.** If fire alarms are provided, they shall have permanently installed audible and visible alarms complying with NFPA 72 (1999 or 2002 edition).
ADASAD 215, 702
- B.** Audible alarms shall produce a sound pressure level of 15 decibels (dB) above the average ambient sound level or 5 dB above the maximum sound level having the duration of at least 60 seconds, whichever is greater, in every occupiable space within the building. The minimum sound pressure levels shall be: 75 dB in residential occupancies; 90 dB in mechanical equipment rooms; and 60 dB in other occupancies.
CBC 9-907.5.2.1.1
- C.** Visible alarm notification appliances shall be provided in accordance with CBC Chapter 9, Sections 907.5.2.3.1 through 907.5.2.3.5.
- D.** Fire alarm pulls are to be a minimum of 42" and a maximum of 48" above the floor to the highest point of the activating handle or lever of the box.
CBC 9-907.4.2.2
- E.** Fire alarm pull stations shall be accessible and operable without tight grasping, pinching, or twisting. The force required to activate pulls shall be 5 lbs. (22.2 N) maximum.
CBC 11B-309.4

Assistive Listening Systems

I. CONCEPT

- A. Assistive listening systems (ALS) are used to help individuals hear the programs that State Parks provides. These systems may be either permanently installed or portable. Permanent systems are generally installed for specific areas while portable systems allow use for walking tours or similar activities. Typical areas in the parks where ALS will be used are assembly areas, meeting rooms, campfire centers, visitor centers and museums. Selecting or specifying an effective ALS for a large or complex venue often requires the assistance of a professional sound engineer.
- B. Types of ALS include, but are not limited to, hard wired systems, audio-induction loops, radio frequency systems and infrared transmission.

The type of ALS should be selected for the appropriate application. For example, in a room where fluorescent lighting is used, the ballasts can cause interference with infrared systems. Infrared may be appropriate for interpretive centers with audio/visual presentations but not functional in outdoor settings without clear lines of sight.

- C. With any system, visitors must be aware that it is available and staff must be trained on system use and maintenance.

II. GENERAL

- A. In public assembly areas, conference and meeting rooms where audible communication is integral to the use of the space, ALS for persons with hearing impairments shall be provided.

ADASAD 219.2

1. The minimum number of receivers to be provided shall be equal to 4% of the total number of seats, but in no case less than two.

ADASAD 219.3

2. 25% and no fewer than two of the total number of receivers provided shall be hearing aid compatible.

ADASAD 219.3

Section 2 - Assistive Listening Systems

3. Receivers required to be hearing aid compatible shall interface with telecoils in hearing aids through the provision of neckloops.
ADASAD 706.3
 4. Receivers required for use with an ALS shall include a 1/8" standard mono jack.
ADASAD 706.2
 5. ALS shall be capable of providing a sound pressure level of 110 dB minimum and 118 dB maximum with a dynamic range on the volume control of 50 dB.
ADASAD 706.4
 6. The signal to noise ratio for internally generated noise in ALS shall be 18 dB minimum.
ADASAD 706.5
 7. Peak clipping shall not exceed 18 dB of clipping relative to the peaks of speech.
ADASAD 706.6
- B.** If the ALS provided is limited to specific areas or seats, then such areas or seats shall be within a 50' unobstructed viewing distance of the performing area.
CBC 11B-219.4
- C.** A permanently installed ALS is required in areas if (1) they accommodate at least 50 persons or they have audio-amplification systems, and (2) they have fixed seating. If a portable ALS is used for conference or meeting rooms, the system may serve more than one room.
CBC 11B-219.5

III. SIGNAGE

- A.** A visual sign shall be posted in a prominent place indicating the availability of the ALS and shall include the International Symbol of Access for Hearing Loss.
ADASAD 703.7.2.4
- ★ Refer to Section 36 - Signage for design specifications.

Audiovisual Programs

I. CONCEPT

- A.** Audiovisual programs are informational, educational, interpretive, or training programs that are transmitted by auditory and/or visual means with the aid of audiovisual equipment. Audiovisual programs include- but are not limited to- live presentations with an audiovisual component (e.g. PowerPoint, video, etc.), live interactive videoconference presentations, exhibits with an audiovisual component, and streaming audiovisual programs.
- B.** The Accessibility Compliance Checklist for Audiovisual Programs may be found in the Appendix. This checklist contains the basic elements necessary for accessible design. Refer to this checklist when developing or redesigning audiovisual programs to ensure that they are accessible and legally compliant with all statutes and regulations.
- C.** It is recommended that park staff consult with the Information Technology Office to ensure that audiovisual programs meet the technical requirements of the Section 508 Standards.

II. GENERAL GUIDELINES

- A.** Audiovisual programs are required to be presented in and available from, accessible locations.
 - ★ Refer to Section 7 - Buildings, Section 8 - Campfire Centers & Assembly Areas, and Section 34 - Routes of Travel.
- B.** For any public participation program or event, Districts are responsible for providing a qualified sign language interpreter upon request.
DOM 2607.5, DN 2004-07
- C.** Assistive listening systems shall be provided in each public assembly area where audible communication is integral to the use of the space.
ADASAD 219.2
 - ★ Refer to Section 2 - Assistive Listening Systems and Section 8 - Campfire Centers & Assembly Areas.

Section 3 - Audiovisual Programs

- D. Audiovisual programs which are freestanding, non-portable, and intended to be used in one location and which have operable controls shall comply with the requirements for clear floor space, reach range, and operable parts as outlined in Section 0.1 - Accessibility Basics and knee clearance as outlined in Section 12 - Dining & Banquet Areas.
29 U.S.C. 794d 1194.25(j)

III. AUDIOVISUAL EQUIPMENT GUIDELINES

- A. All analog televisions, computer monitors, and digital televisions which are used to transmit informational, educational, interpretive or training programs shall be equipped with caption decoder circuitry which appropriately receives, decodes, and displays captions from- but not limited to- broadcast, cable, videotape, and DVD signals.
29 U.S.C. 794d 1194.24(a)
- B. Television tuners, including tuner cards for use in computers, shall be equipped with secondary audio program (SAP) playback circuitry.
29 U.S.C. 794d 1194.24(b)
- C. Exhibits featuring an audiovisual program shall be usable by people with disabilities without requiring an end-user to attach assistive technology to the exhibit. Personal headsets for private listening are not assistive technology.
29 U.S.C. 794d 1194.25(a)
- D. Where an exhibit with an audiovisual program utilizes touch screens or contact-sensitive controls, an input method to connect a keyboard shall be provided that complies with the following:
29 U.S.C. 794d 1194.25(c)
1. Controls and keys shall be operable with one hand and shall not require tight grasping, pinching, or twisting of the wrist. The force required to activate controls and keys shall be 5 lbs. maximum.
 2. If key repeat is supported, the delay before repeat shall be adjustable to at least 2 seconds. Key repeat rate shall be adjustable to 2 seconds per character.
 3. The status of all locking or toggle controls or keys shall be visually discernable, and discernable either through touch or sound.

Section 3 - Audiovisual Programs

- E.** When an exhibit with an audiovisual program provides auditory output, the audio signal shall be provided at a standard signal level through an industry standard connector that will allow for private listening. The exhibit must provide the ability to interrupt, pause, and restart the audio at any time.
29 U.S.C. 794d 1194.25(e)
- F.** When an exhibit with an audiovisual program delivers voice output in a public area, incremental volume shall be provided with output amplification up to a level of at least 65 dB. Where the ambient noise level of the environment is above 45 dB, a volume gain of at least 20 dB above the ambient level shall be user selectable. A function shall be provided to automatically reset the volume to the default level after every use.
29 U.S.C. 794d 1194.25(f)

IV. AUDIOVISUAL PROGRAM DESIGN GUIDELINES

- A.** For all audiovisual programs the basic principles of accessible exhibit design apply where applicable. This includes layout, font, contrast, color and requirements by exhibit type. Refer to **Section 18 - Exhibits, Part III**. Audiovisual programs transmitted using a touchscreen shall follow the font guidelines for exhibits. Audiovisual programs transmitted using a television, monitor, or projector shall follow the guidelines in letter B of this section.
- B.** Audiovisual programs that transmit their content through either a projector with a screen, an analog TV or monitor, or a digital TV or monitor shall use **Table 3-1** or **Table 3-2** to determine the comfortable viewing distance. Minimum font size shall be 18-point.

To use the tables:

- Locate the row that corresponds to the width of the screen you are using.
- Locate the column corresponding to the smallest font used for text on your slides.
- The intersection of the row and column is the maximum distance from the screen that an audience member should be seated in order to be able to easily read the text.

Section 3 - Audiovisual Programs

1. Use **Table 3-1** when the audiovisual program is transmitted using an analog television or monitor (4:3 width to height ratio), or most projectors/screens.

Table 3-1 Comfortable Viewing Distance for Text on Audiovisual Programs (projectors, analog TVs and monitors)

		Font size (in points)						
		18	24	28	32	36	40	44
Screen width (inches)	36	19	27	31	34	38	42	46
	48	25	36	41	46	51	56	61
	60	32	44	51	57	64	70	76
	72	38	53	61	69	76	84	92
	84	44	62	71	80	89	98	107
	96	51	71	81	92	102	112	122
	120	64	89	102	114	127	140	153
	Comfortable viewing distance (feet)							

2. Use **Table 3-2** when the audiovisual program is transmitted using a widescreen digital TV or monitor (16:9 width to height ratio), or a widescreen projector/screen.

Table 3-2 Comfortable Viewing Distance for Text on Audiovisual Programs (projectors, digital TVs and monitors)

		Font size (in points)						
		18	24	28	32	36	40	44
Diagonal screen size (inches)	15	5	7	8	9	10	11	12
	19	7	9	11	12	13	14	16
	22	8	11	12	14	15	17	18
	27	9	13	15	17	19	21	22
	32	11	15	18	20	22	24	27
	36	12	17	20	22	25	27	30
	42	15	20	23	26	29	32	35
	47	16	23	26	29	32	36	39
	52	18	25	29	32	36	40	43
	60	21	29	33	37	41	46	50
	72	25	35	40	45	50	55	60
80	28	39	44	50	55	61	66	
Comfortable viewing distance (feet)								

Section 3 - Audiovisual Programs

- C.** Where an audiovisual program is part of an exhibit, the lighting requirements shall be consistent with those as outlined in *Section 18 - Exhibits, Part III*. Where an audiovisual program is held in a public assembly area, either indoors or outdoors, minimum lighting at floor or ground level shall not be any less than 1 foot-candle. This is the minimum level of lighting required for safe egress in case of emergency.
- D.** For interactive audiovisual programs, when a timed response is required, the user shall be alerted and given sufficient time to indicate more time is required.
29 U.S.C. 794d 1194.25(b)
- E.** Color coding shall not be used as the only means of conveying information, indicating an action, prompting a response, or distinguishing a visual element.
29 U.S.C. 794d 1194.25(g)
- F.** When an exhibit with an audiovisual program permits a user to adjust color and contrast settings, a variety of color selections capable of producing a range of contrast levels shall be provided.
29 U.S.C. 794d 1194.25(h)
- G.** When transmitted on a television or monitor, audiovisual programs shall be designed to avoid causing a television or monitor to flicker with a frequency greater than 2 Hz and lower than 55 Hz.
29 U.S.C. 794d 1194.25(i)
- H.** All training and informational video and multimedia productions which support the Department's mission, regardless of format, that contain speech or other audio information necessary for the comprehension of the content, shall be captioned.
29 U.S.C. 794d 1194.24(c)

 - 1. Multiple types of captions are available including: on-screen open captions, subtitles for the deaf and hard of hearing (SDH), or caption boards. The type of captions provided shall be at the discretion of audiovisual program planners and designers. Captions shall be accurate, synchronous, complete and properly placed.
47 CFR Part 79 §79.1(j) (2), §79.101-§79.102

Section 3 - Audiovisual Programs

- a. Accurate: captions must match the spoken words in the dialogue and convey background noises and other sounds to the fullest extent possible.
 - i. Captions shall identify who is speaking.
 - ii. Captions shall use upper and lowercase letters.
 - b. Synchronous: captions must coincide with their corresponding spoken words and sounds to the greatest extent possible and must be displayed on the screen at a speed that can be read by viewers.
 - i. Captions shall appear on no more than four rows, with no more than 32 characters per row on analog displays or 42 characters per row on digital displays.
 - ii. All programs shall be captioned at a presentation rate range not to exceed 120-130 words per minute. No caption shall remain onscreen less than two seconds.
 - iii. Captions shall be pop-on/pop-off (vs. roll-up).
 - c. Complete: captions must run from the beginning to the end of the program to the fullest extent possible.
 - d. Properly placed: captions should not block other important visual content on the screen, overlap one another, or run off the edge of the video screen (title-safe area).
 - i. The height of the tallest character in any caption font shall be no taller than 1/15 of the height of the title-safe area, and the width of the widest character shall be no wider than 1/32 of the width of the title-safe area for 4:3 displays and 1/42 of the title-safe area for 16:9 displays.
 - ii. Caption font shall be white over a dark translucent box.
- I. All training and informational video and multimedia productions which support the Department's mission, regardless of format, that contain visual information necessary for the comprehension of the content shall be audio described.
29 U.S.C. 794d 1194.24(d)

Section 3 - Audiovisual Programs

1. Audio description is the concise, objective, verbal depiction of key visual elements placed between portions of dialogue or songs that guide the listener through an audiovisual program. Key visual elements include- but are not limited to- new scenes, settings, clothing, body language, and sight gags (anything which conveys its humor visually).
 - a. Audio description of the above elements shall be synchronized to the program and shall be transmitted using an assistive listening system or other device.
 - ★ Refer to Section 2 - Assistive Listening Systems.
 2. A tactile sign shall be posted in a prominent location indicating the availability of audio description and shall include the Symbol for Audio Description.
 - ★ Refer to Section 36 - Signage for design specifications.
- J. Where possible and appropriate, audiovisual programs should include the experiences and “voices” of people with disabilities.

V. ALTERNATE FORMATS

- A. Alternative means of presenting audiovisual programs shall be readily available. The responsibility for creating alternate formats lies with the originator of the audiovisual program and should be considered a program deliverable during the planning and design phase. Alternate formats for existing audiovisual programs are the responsibility of the party managing audiovisual programs in the District.
1. Alternate formats include but are not limited to: Braille, large print format (minimum 18 point sans serif), transcripts, digital or web format, touchable objects, etc.

VI. REFERENCES

- A. Paradi, Dave. “Selecting the correct font size.” *Think Outside The Slide*. Accessed January 2015, <http://www.thinkoutsidetheslide.com/selecting-the-correct-font-size/>
- B. “Closed Captioning on Television.” *Federal Communications Commission*. Accessed November 2014, <http://www.fcc.gov/guides/closed-captioning>

Section 3 - Audiovisual Programs

- C. “Programmatic Accessibility Guidelines for National Park Service Interpretive Media.” *Harpers Ferry Center, National Park Service*, February 2012. Accessed January 2015, <http://www.nps.gov/hfc/accessibility/>
- D. “Captioning Key.” *The Described and Captioned Media Program*. Accessed March 2015, <http://captioningkey.org/index.html>
- E. “What is Audio Description?” *The Audio Description Project, American Council of the Blind*. Accessed November 2014, <http://acb.org/adp/ad.html#what>

Bathing Facilities

I. CONCEPT

- A.** Where facilities for bathing are provided, including showers or bathtubs, they shall be accessible and conform to the following standards:

ADASAD 213

1. Showers shall be finished as specified in California Plumbing Code 411.7 to a height of not less than 70" above the drain inlet. Materials other than structural elements used in such walls shall be of a type which is not adversely affected by moisture.
 2. Doors and panels of shower and bathtub enclosures shall be substantially constructed from approved, shatter-resistant materials. Hinged shower doors shall open outward.
 3. Glazing used in doors and panels of shower and bathtub enclosures shall be fully tempered, laminated safety glass or approved plastic. When glass is used, it shall have minimum thickness of not less than 1/8" when fully tempered or 1/4" when laminated.
 4. Plastics used in doors and panels of showers and bathtub enclosures shall be shatter-resistant.
- B.** Where, within the same functional area, two or more accessible showers are provided, there shall be at least one shower constructed opposite hand from the other or others (i.e., one left-hand control versus right-hand controls).
- C.** Dressing areas within shower rooms shall comply with the requirements for dressing rooms.
★ Refer to Section 15 - Dressing Rooms.

II. COMPARTMENT SHOWERS – CBC 11B-608.2

A. Enclosure/Stall

1. The shower stall space shall meet one of the following criteria:

Section 4 - Bathing Facilities

- a. Roll-in shower: 60" minimum width between wall surfaces and 30" minimum depth, with a full opening width on the long side.

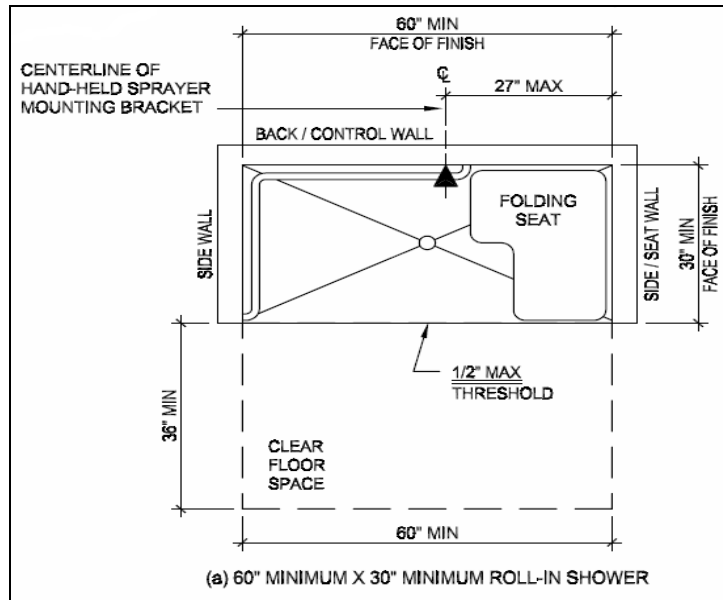

Figure 4-1 Standard Roll-In Type Shower Compartment Size and Clearance

- b. Alternate roll-in shower (1): 60" minimum width between wall surfaces and 36" minimum depth with an entrance opening width of 36" minimum.

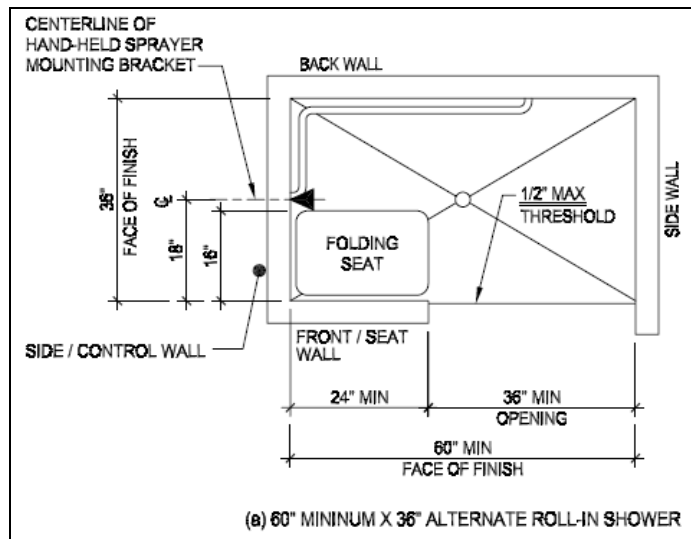

Figure 4-2 Alternate (1) Roll-In Type Shower Compartment Size and Clearance

Section 4 - Bathing Facilities

- c. Alternate roll-in shower (2): 60" minimum width between wall surfaces and 36" minimum depth with an entrance opening width of 36" minimum.

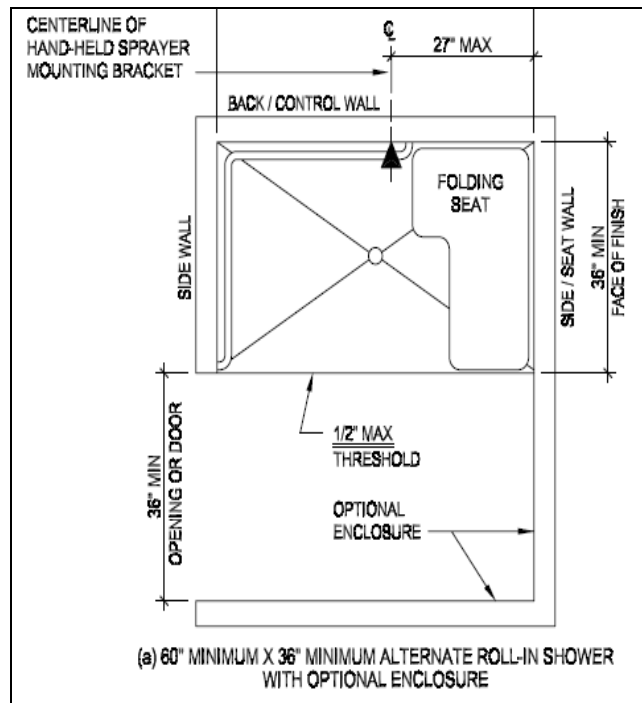

Figure 4-3 Alternate (2) Roll-In Type Shower Compartment Size and Clearance

- d. In "Barrier Removal" work, when trying to provide an accessible shower within an existing envelope that does not allow a shower enclosure with dimensions show in a, b, or c above, a Transfer Type Shower Compartment may be utilized. Transfer type shower compartments shall be 36" (915 mm) by 36" (915 mm) clear inside dimensions measured at the center points of opposing sides and shall have a 36" (915 mm) wide minimum entry on the face of the shower compartment. Clearance of 36" (915 mm) wide minimum by 48" (1220 mm) long minimum measured from the control wall shall be provided.

Section 4 - Bathing Facilities

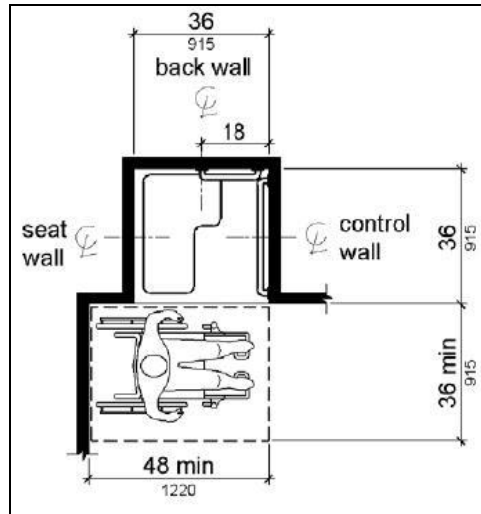

Figure 4-4 Transfer Type Shower Compartment Size and Clearance

2. When a threshold or recessed drop is permitted, it shall be a maximum of $\frac{1}{2}$ " in height and shall comply with *CBC 11B-303*.
3. Enclosures, when provided for shower compartments, shall not obstruct controls or obstruct transfer from wheelchairs onto shower seats.
CBC 11B-608.8

B. Shower floor:

1. Drain grate openings shall be a maximum of $\frac{1}{4}$ " wide. Drain shall be flush with the floor.
CBC 11B-608.9
2. Maximum slope of the floor shall be 2% in any direction.
CBC 11B-608.9
3. Floor surfaces shall be stable, firm and slip resistant.
CBC 11B-608.9

Section 4 - Bathing Facilities

C. Shower Compartment Seats:

1. The seat shall resist a 250 lb. force in any direction.
CBC 11B-610.4
2. The seat shall be mounted 17"-19" above the floor.
CBC 11B-610.3
3. The seat, when folded, shall extend a maximum of 6" from the wall.
CBC 11B-610.3
4. Shower compartment seats shall be folding type and:
 - a. In standard roll-in type shower compartment, shall be installed on the side wall adjacent to the controls, and shall extend from the back wall to a point within 3" of the compartment entry.
CBC 11B-610.3
 - b. In an alternate roll-in type shower compartment, shall be installed on the front wall opposite the back wall, and shall extend from the adjacent side wall to a point within 3" of the compartment entry.
CBC 11B-610.3
 - c. In transfer type showers (allowed in barrier removal work only - not new construction), the seat shall extend from the back wall to a point within 3" of the compartment entry.
CBC 11B-610.3

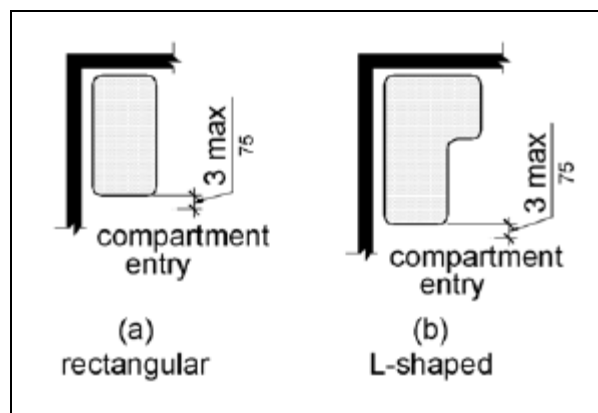

Section 4 - Bathing Facilities

5. The rear edge of a rectangular seat shall be $2\frac{1}{2}$ " maximum and the front edge 15" minimum and 16" maximum from the seat wall. The side edge of the seat shall be $1\frac{1}{2}$ " maximum from the adjacent wall.

CBC 11B-610.3

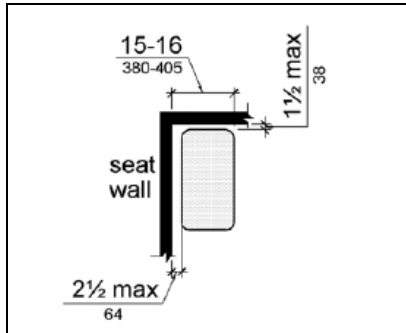

Figure 4-6 Rectangular Shower Seat

6. The rear edge of an L-shaped seat shall be $2\frac{1}{2}$ " maximum and the front edge 15" minimum and 16" maximum from the seat wall. The rear edge of the "L" portion of the seat shall be $1\frac{1}{2}$ " maximum from the wall and the front edge shall be 14" minimum and 15" maximum from the wall. The end of the "L" shall be 22" minimum and 23" maximum from the main seat wall.

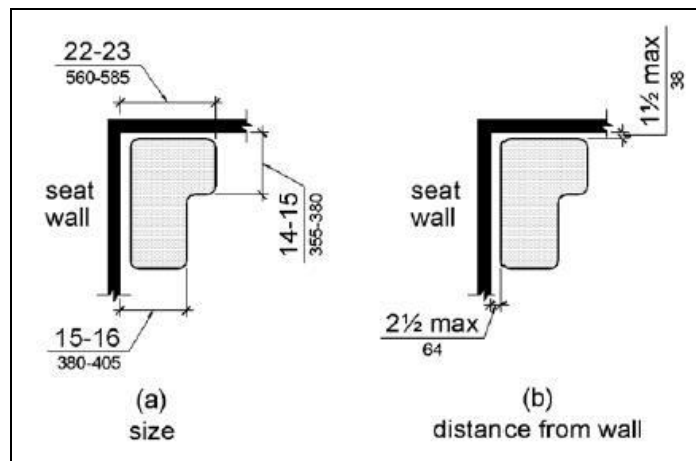

Figure 4-7 L-Shaped Shower Seat

Section 4 - Bathing Facilities

D. Doors and Panels:

1. Doors and panels shall be substantially constructed from approved, shatter-resistant materials. Hinged shower doors shall open outward.
2. Door latches, mounted 34" to 48" above the floor, shall be flip-over, sliding or similar style not requiring grasping or twisting.
CBC 11B-404.2.7
3. The maximum pressure required to open a door must be 5 lbs. or less.
CBC 11B-404.2.9
4. The required strike edge clearance on the pull side of an interior stall door is 18" for front approach, 24" for latch approach and 24" for hinge approach.
CBC 11B-404.2.4

E. Accessories:

1. Clothes hooks, if provided, shall be located within one of the prescribed reach ranges.
CBC 11B-603.4
★ Refer to Section 0.1 - Accessibility Basics, Part VIII Reach Range.
2. Shelves, if provided, shall be located 40" minimum and 48" maximum above the finish floor.
CBC 11B-603.4
3. Soap dispensers, if provided, shall be located on the control wall at a 40" maximum from the finish floor, and within the reach limits from the seat.
CBC 11B-608.10

III. WATER CONTROLS

A. Location of Controls – *CBC 11B-608.5*

1. In standard roll-in type shower compartments, operable parts of controls and faucets shall be installed on the back wall of the compartment adjacent to the seat wall 19" minimum and 27" maximum from the seat wall; and shall be

Section 4 - Bathing Facilities

located above the grab bar, but no higher than 48" above the shower floor, with their centerline at 39" to 41" above the shower floor.

Operable parts of the shower spray unit, including the handle, shall be installed on the back wall adjacent to the seat wall 19" minimum and 27" maximum from the seat wall; and shall be located above the grab bar, but no higher than 48" above the shower floor.

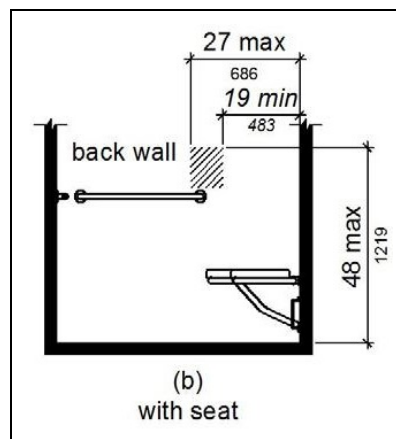

Figure 4-8 Standard Roll-In Type Shower Compartment Control Location

2. In alternate roll-in type shower compartments, operable parts of controls and faucets shall be installed on the side wall of the compartment adjacent to the seat wall 19" minimum and 27" maximum from the seat wall; and shall be located above the grab bar, but no higher than 48" above the shower floor, with their centerline at 39" to 41" above the shower floor.

Operable parts of the shower spray unit, including the handle, shall be installed on the side wall of the compartment adjacent to the seat wall 17" minimum and 19" maximum from the seat wall or on the back wall opposite the seat 15" maximum, left or right, of the centerline of the seat; and shall be located above the grab bar, but no higher than 48" above the shower floor.

Section 4 - Bathing Facilities

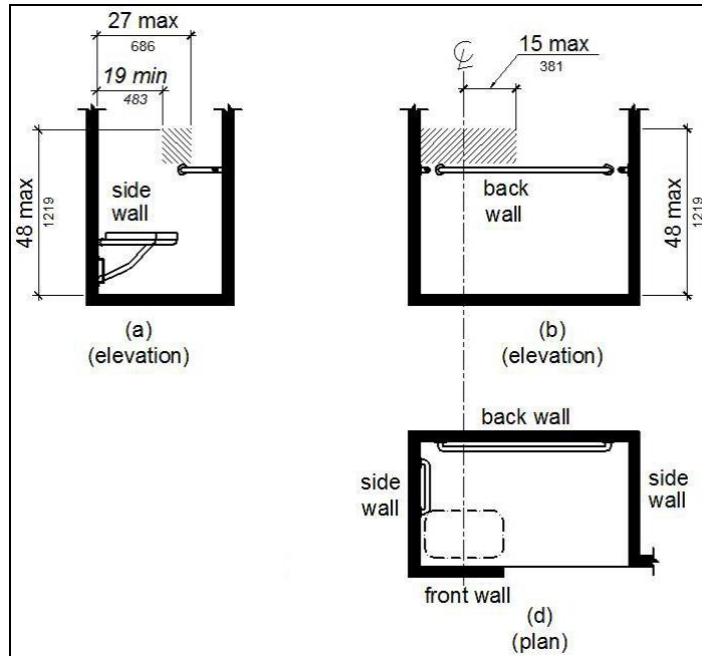

Figure 4-9 Alternate Roll-In Type Shower Compartment Control Location

3. In transfer type shower compartments, the controls, faucets, and shower spray unit shall be installed on the side wall opposite the seat 38" minimum and 48" maximum above the shower floor and shall be located on the control wall 15" maximum from the centerline of the seat toward the shower opening. ADASAD 608.5.1

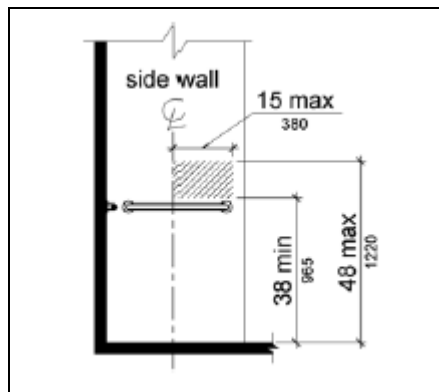

Figure 4-10 Transfer Type Shower Compartment Control Location

Section 4 - Bathing Facilities

B. Hand-Held Shower Spray Unit

1. A shower spray unit with a hose 60" long minimum that can be used both as a fixed-position showerhead and as a hand-held shower shall be provided.
CBC 11B-608.6
2. Where accessible shower facilities are provided in areas subject to excessive vandalism, in lieu of providing the fixed flexible hose and hand-held showerhead required above, two wall-mounted showerheads shall be installed. Each showerhead shall be controlled so that it can be operated independently of the other and shall have swivel angle adjustments, both vertically and horizontally. One showerhead shall be located at a height of 48" above the floor. The other shall be located at a height of 72" above the floor.
CBC 11B-608.6 Exception

C. Effort to Operate

★ Refer to Section 0.1 - Accessibility Basics, Part IX Operable Parts.

D. Coin Slots

1. Coin slots Installed in any accessible shower compartment shall be located at a maximum of 40" above the floor and adjacent to the folding seat in the control area shown in **Figures 4-8 thru 4-10**.

IV. GRAB BARS – CBC 11B-609

- A. An L-shaped grab bar shall be located on the wall opposite of and adjacent to the front edge of the seat. (**Figures 4-1 thru 4-3**)
- B. Grab bars shall be mounted 33" to 36" above the shower floor and mounted on the walls adjacent to and opposite of the seat provided in the tub/shower stall.

Section 4 - Bathing Facilities

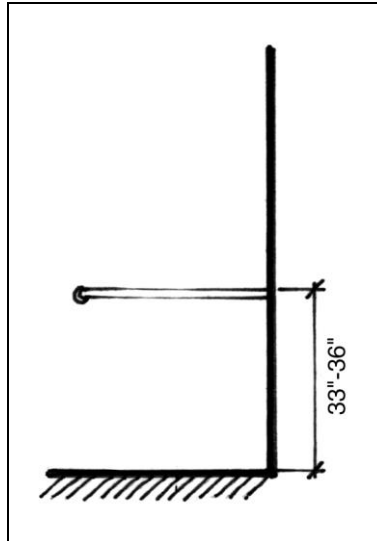

Figure 4-11 Grab Bar Mounting Height

- C. Grab bars shall comply with the diameter, loading and projection requirements for toilets.
★ Refer to Section 33 - Restrooms, Part IV Grab Bars.

V. OUTDOOR RINSING SHOWERS

- A. At each location where outdoor showers are provided, at least one outdoor shower must be accessible. In order to evaluate the accessibility of outdoor showers (e.g. beach showers) the following items will need to be reviewed and measured utilizing the appropriate portions of the restroom survey or as otherwise noted.
- B. Path of Travel:
★ Refer to Section 34 - Routes of Travel.
- C. Minimum clear ground space shall be 60" by 60" centered on the shower heads. Locate the space so that the shower pedestal or wall with the showerhead is at the rear end of the space.
AGODA 1011.2

Section 4 - Bathing Facilities

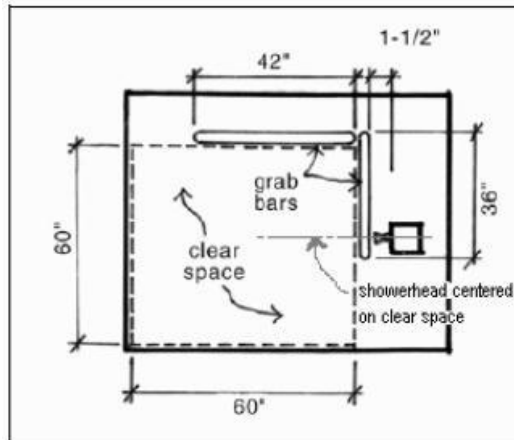

Figure 4-12 Minimum Clear Ground Space for Outdoor Rinsing Showers

- D. The surface must be firm, stable and slip resistant.
CBC 11B-302
- E. The slope shall not be steeper than 2% in any direction.
AGODA 1011.2.3
- F. Two fixed showerheads shall be provided. One at a 48" above the ground and one at a minimum of 72" above the ground.
AGODA 1011.7 Exception, 99AG 16.19.2.1

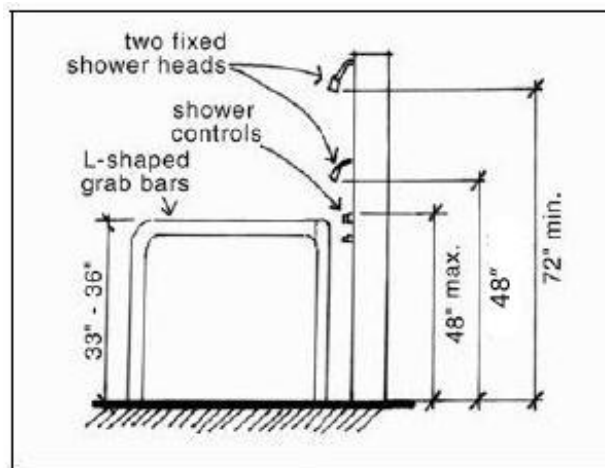

Figure 4-13 Outdoor Rinsing Shower Showerhead Height

Section 4 - Bathing Facilities

G. Shower Controls:

1. If valves are self-closing, water should remain on for a minimum of 10 seconds.
99AG 16.19.2.6
2. The maximum effort to operate controls should be 5 lbs. or less.
AGODA 1011.3
3. Controls must be operable with one hand, not requiring tight grasping or twisting.
AGODA 1011.3
4. Controls shall be located maximum 48" above the ground. **(Figure 4-13)**
AGODA 1011.3

H. Grab bars at outdoor rinsing showers shall be provided as follows:

99AG 16.19.2.3-5

1. Vertical Grab Bar. Where the showerhead is mounted on a post, a vertical grab bar shall be provided under the showerhead and shall start 33" maximum above the floor and extend to within at least 3" of the showerhead.
2. Circular Grab Bar. Where the showerhead is mounted on a post, a grab bar that surrounds the usable part of the post shall be provided. The grab bar shall be provided 33" minimum to 36" maximum above the floor.
3. Horizontal Grab Bar. A horizontal grab bar extending 18" minimum in both directions from the center line of the showerhead shall be provided under the showerhead. The grab bar shall be provided 33" minimum to 36" maximum above the floor. **(Figure 4-13)**

Section 4 - Bathing Facilities

VI. SIGNAGE

- A. All bathing facilities shall be identified by both a visual and a tactile sign installed on the wall adjacent to the latch side of bathing facility doors. This sign shall comply with the guidelines for visual and tactile signs, height, and location as specified in *Section 36 - Signage*.

CBC 11B-216.2

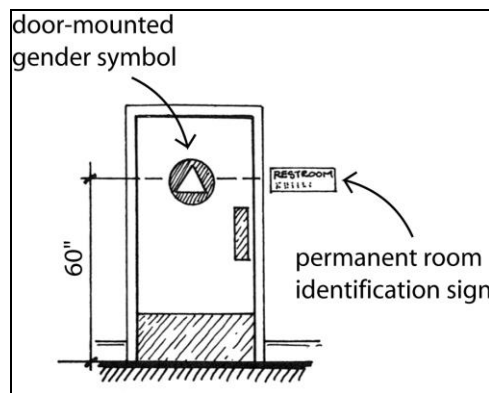

Figure 4-14 Bathing Facility Signage

1. Bathing facilities that are accessible shall include, on the visual sign, the International Symbol of Accessibility as specified in *Section 36 - Signage*.
- B. All bathing facility doors shall be identified by a geometric symbol that complies with the guidelines for symbols as specified in *Section 36 - Signage*.
- CBC 11B-216.8
- C. Where existing bathing facilities are not accessible, visual directional signs indicating the location of the nearest accessible bathing facility, if any, shall be provided.
1. Visual signs shall comply with the guidelines found in *Section 36 - Signage* and shall include the International Symbol of Accessibility.

Beaches and Shores

I. CONCEPT

- A.** Designated beaches and day-use areas shall be accessible.
AGODA F248, CBC 11B-246.3
- B.** The major barrier to shore and beach use by persons with mobility impairments is the difficulty traversing sandy or loose soil. For some water activities, such as fishing or swimming, it is necessary to have direct physical contact with the water from the beach or shore. Access to these activities involves two basic considerations:
1. Access to the edge of the beach or shore from accessible parking spaces, common use areas and support facilities. These routes must be consistent with the requirements for accessible routes of travel
★ Refer to Section 34 - Routes of Travel.
 2. Access across the beach to the activity (the water's edge). These routes are known as Beach Access Routes.
- C.** All newly constructed beach, river, lake and shoreline facilities shall have at least one permanent or removable beach access route for every ½ mile of linear shoreline.
AGODA F248.2
- D.** At existing beaches or shores, Beach Access Routes shall be provided whenever the following activities are undertaken:
- * New or altered pedestrian paths.
 - * New or altered parking facilities.
 - * New or altered toilet or bathing facilities.
 - * Beach Nourishment projects.
- AGODA F248.1.1-2*
- E.** Beach Access Routes are not required where certain site conditions exist, however exemptions from compliance must be fully documented and formally

Section 5 - Beaches and Shores

approved by the Accessibility Section. For additional assistance regarding beach access, ☎ contact the Accessibility Section.

II. BEACH ACCESS ROUTES

- A. The beach access route shall be located in the same area as the general circulation path, and shall extend to the high tide level, mean riverbed level or the normal recreation pool level.
AGODA F248.3, 1018.2
- B. The minimum clear width of a non-removable beach access route shall be 60".
AGODA 1018.4

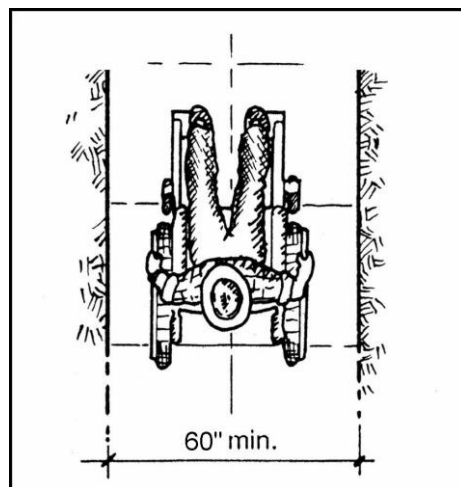

Figure 5-1 Minimum Clear Width of Non-Removable Beach Access Route

- C. The surface of the beach access route shall be firm and stable.
AGODA 1018.3
- D. Openings in the route surface, such as on a boardwalk, shall be $\frac{1}{2}$ " or less if perpendicular or diagonal to the route. They shall be $\frac{1}{4}$ " or less if parallel to the route.
AGODA 1018.6, 99AG 16.2.3 Exception 1

Section 5 - Beaches and Shores

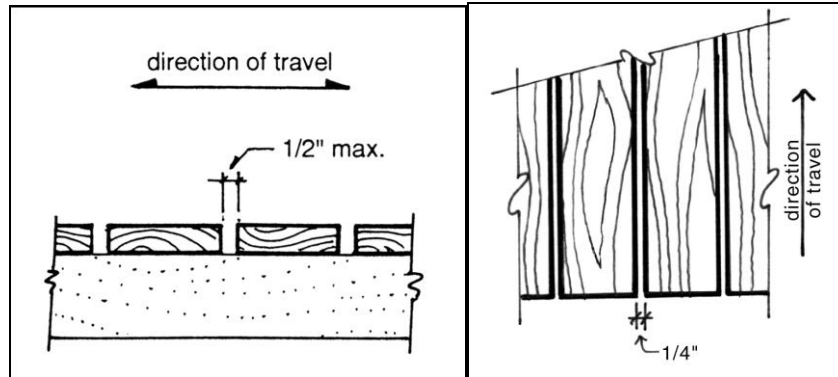

Figure 5-3 Elongated Openings in Route Surface

- E. A warning curb shall be provided where there is a vertical drop exceeding 4" adjacent to the beach access route.
★ Refer to Section 0.1 - Accessibility Basics, Part III Changes in Level.
- F. Objects shall not protrude into the beach access route excepted as allowed per ADASAD 307.
★ Refer to Section 0.1 - Accessibility Basics, Part VII Protruding Objects.
- G. Running slope for beach access routes shall comply with **Table 5-1**: AGODA 1018.7.1

Table 5-1 Maximum Running Slope and Segment Length

Running Slope of Beach Access Route Segment		Maximum Length of Segment
Steeper than	But not Steeper than	
0%	5%	No limit
5%	8.33%	50'
8.33%	10%	30'

- H. The cross slope for beach access routes shall not be steeper than 2%.
- I. Where the running slope of a segment of a beach access route is steeper than 5%, the maximum length of the segment shall comply with Table 5-1, and a resting interval shall be provided at the top and bottom of each segment per **Table 5-2**: AGODA 1018.7.1

Section 5 - Beaches and Shores

Table 5-2 Maximum Running Slope and Rest Intervals

Running Slope of Beach Access Route Segment		Rest Interval
Steeper than	But not Steeper than	
0%	5%	None required
5%	8.33%	Every 50'
8.33%	10%	Every 30'

- J.** Rest intervals shall be 60” minimum by 60” minimum and shall have a slope not steeper than 2% in any direction.

Exception: the slope of the resting space can be as great as 5% if the surface is other than concrete, asphalt, or boards, and is required for proper drainage.

AGODA 1018.8.2

- K.** A level maneuvering space measuring a minimum of 60” x 60” shall be provided at the end of the beach access route.

- L.** All obstacles in the beach access route shall be less than 1/2” high.

AGODA 1018.5

III. DESIGNATED SWIMMING AREAS

- A.** Depending on safety needs and local site conditions, designated swimming areas should be clearly defined in the water with highly visible floating devices.

- B.** Depending on safety needs and local site conditions, designated swimming areas should also be identified on shore with clearly visible signage.

IV. ACCESS TO WATER

- A.** When feasible, considering site conditions at designated swimming areas, a firm and stable surface should provide access into the water. An additional option may be a beach wheelchair. 📞 Contact the Accessibility Section to help determine if water access is necessary and/or feasible in your specific area.

Section 5 - Beaches and Shores

- B.** Beach wheelchairs allow assisted access to the beach for people who use wheelchairs. If beach wheelchairs are provided, a visual sign shall be posted to indicate their availability and shall include the International Symbol of Accessibility.
- ★ Refer to Section 36 - Signage for design specifications.
- C.** Whenever beach access is designated as a program which is or will be made accessible, at least two beach wheelchairs will be provided at such parks unless:
1. There are no staff or facilities at the park available to store and supervise the use of the wheelchairs and/or:
 2. The slope conditions at the park make use of beach wheelchairs hazardous.
- D.** Additional beach wheelchairs will be provided at appropriate locations if and when usage indicates that additional beach wheelchairs are needed at such locations.

Boating

I. CONCEPT

- A.** Boating facilities include facilities to launch and moor boats and all associated structures, such as docks, piers, marinas and gangways. If a site presents challenges to meeting the guidelines, such as highly fluctuating water surfaces,  Contact the Accessibility Section for assistance with alternative design and/or mechanical devices.
- B.** Boating facilities, docks, fishing piers, etc. shall be accessible.
ADASAD 235

II. BOATING FACILITIES CAN CONSIST OF THE FOLLOWING:

- A.** Boat Launch Ramp: Surface designed for the launch and retrieval of boats.
- B.** Boat Slip: Area where boat is tied to a dock or pier for the purpose of embarking and disembarking.
- C.** Gangway: Variable-sloped pedestrian walkway linking a fixed structure or land with a floating structure.
- D.** Pier: Structure at which boats are intended to moor for the purposes of embarking or disembarking occupants to the structure.

III. GANGWAYS

- A.** Gangways are considered to be part of the accessible route, shall have slopes no greater than 8.33%, and shall comply with *Section 34 - Routes of Travel*.
ADASAD 1003.2

Section 6 - Boating

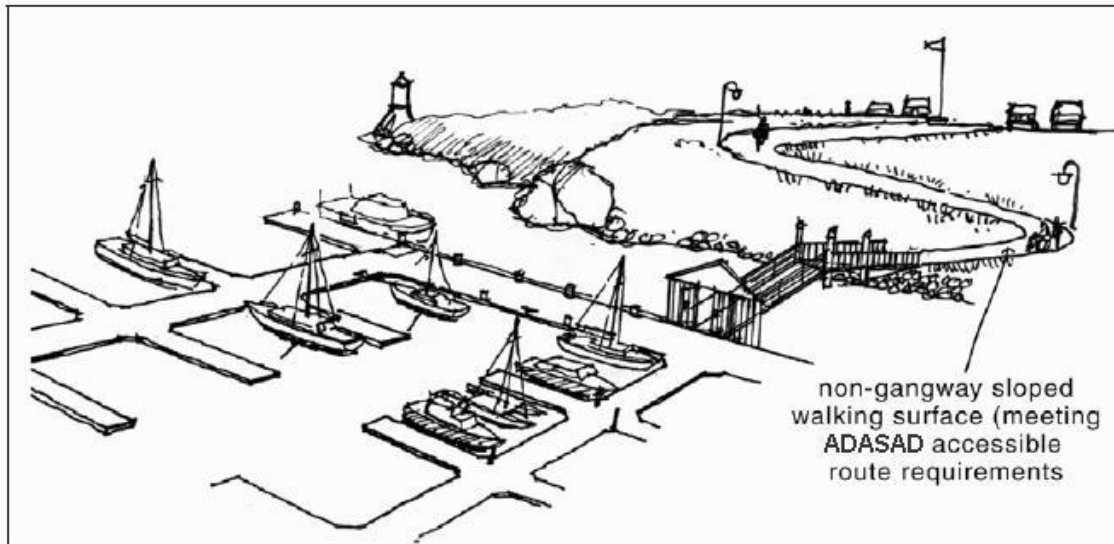

Figure 6-1 Accessible Route Serving Recreational Boating Facility

- B. Transition plates are permitted at the top and bottom of the gangway.

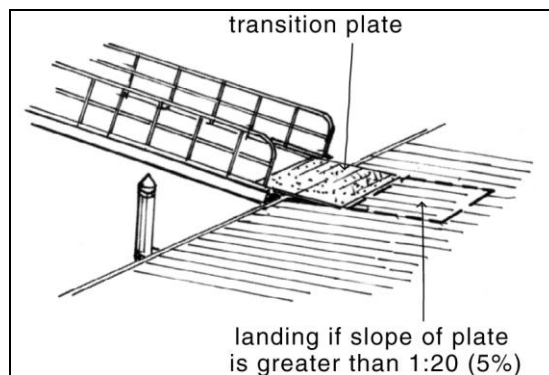

Figure 6-2 Transition Plate Placement and Slope

- C. Gangways are not required to have landings at the end if transition plates of less than 1:20 (5%) slope are provided. If slope is greater than 1:20 (5%), the transition plate must have a landing at the non-gangway end of the transition plate. **(Figure 6-2)**
ADASAD 1003.2.1(5)

Section 6 - Boating

D. Extremes in operating conditions due to fluctuations in water levels require that some exceptions be allowed:

1. Maximum rise of 30" shall not apply to gangways. As a result, no intermediate landings on gangways are required and gangways may be any length.

ADASAD 1003.2.1(2)

2. Handrail extensions are not required on gangways and landings where they connect to transition plates and shall not be required on transition plates.

ADASAD 1003.2.1(6)

3. At boat slips, where the total length of the gangway or series of gangways serving as part of a required accessible route is at least 80', the maximum slope specified, 8.33%, shall not apply to the gangways.

ADASAD 1003.2.1(3)

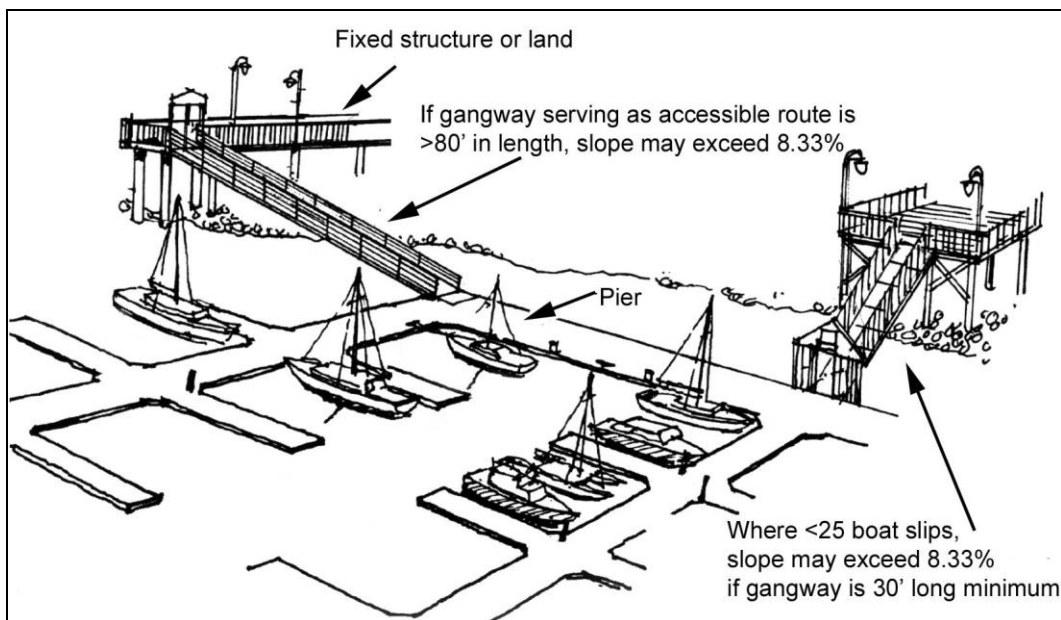

Figure 6-3 Gangway Slope Exceptions

4. In smaller facilities with less than 25 boat slips, the slope of the gangway may exceed 1:12 (8.33%), if the gangway is a minimum of 30' long (Maximum length is not applicable). **(Figure 6-3)**

ADASAD 1003.2.1(4)

Section 6 - Boating

5. At accessible routes serving boarding piers at boat launch ramps; where the total length of the gangway or series of gangways serving as part of a required accessible route is at least 30', the maximum slope of 8.33% shall not apply to the gangway.

ADASAD 1003.2.2(2)

E. When it is not feasible to provide an accessible gangway due to extremes in operating conditions, other accessible options (including mechanical lifts) will be considered.

IV. BOAT SLIPS

A. Where boat slips are not demarcated or identified by length, each 40' of boat slip edge along the perimeter of a pier will be counted as one boat slip. For example, a 60' pier with boats moored on either side (120' total slip length) would equal three boat slips.

ADASAD 235.2

B. When boat slips are provided, the number of boat slips required to be accessible must comply with the **Table 6-1**:

ADASAD 235.2

Table 6-1 Boat Slips

Number of Accessible Boat Slips Required	
Total Number of Boat Slips Provided in Facility	Minimum Number of Required Accessible Boat Slips
1 – 25	1
26 – 50	2
51 – 100	3
101 – 150	4
151 – 300	5
301 – 400	6
401 – 500	7
501 – 600	8
601 – 700	9
701 – 800	10
801 – 900	11
901 – 1,000	12
1,001 and over	12, plus 1 for each 100, or fraction thereof, over 1,000

Section 6 - Boating

- C. Accessible boat slips shall be dispersed throughout the various types of slips that are provided.

ADASAD 235.2.1

- D. Where boat launch ramps are provided with boarding piers, at least 5%, but no less than one, of the boarding piers complying with ADASAD 1003.2 shall be provided adjacent to the ramp.

ADASAD 235.3

- E. Accessible boat slip/dock shall have a clear pier width a minimum 60" wide and as long as the slip. For every 120" (10') of linear length, the boarding pier/dock will have a clear opening of 60".

ADASAD 1003.3.1

There are three exceptions:

1. Width of clear pier space may be 36" wide for a length of 24", as long as multiple 36" segments are separated by segments that are 60" x 60" x 60" clear.

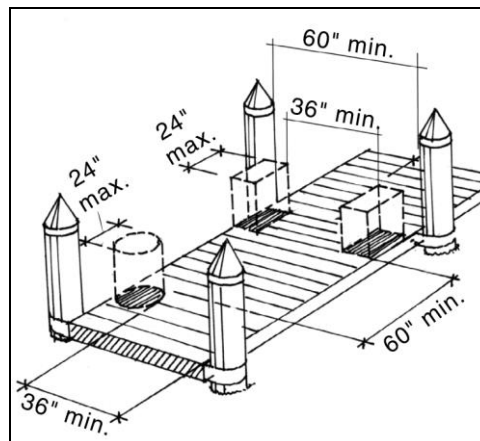

Figure 6-4 Width of Clear Pier Space

2. In alterations, facilities with finger piers must have at least one accessible finger pier, which is the length of the boat slip and a minimum 60" wide. Other accessible slips can be located perpendicular to the end of the pier with the clearance extending the slip width.

Section 6 - Boating

3. If provided, edge protection should be 4" high maximum and 2" deep maximum at the clear openings.

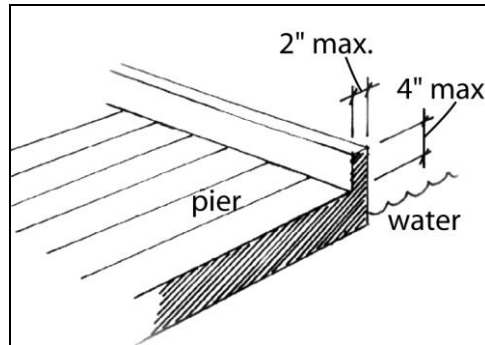

Figure 6-5 Edge Protection

V. SAFETY

- A. Walking surfaces of the facility shall be made of non-slip materials.
- B. Horizontal gaps in walking surfaces (e.g., gratings and planks) shall be perpendicular and less than $\frac{1}{2}$ " wide.
ADASAD 302.3

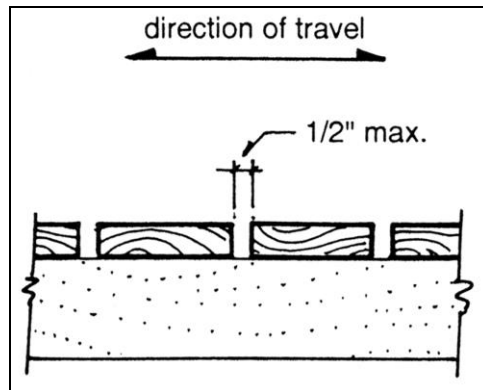

Figure 6-6 Elongated Openings in Ground Surface

- C. Vertical joints in the surface of the facility (including shore connection) shall have a maximum height of $\frac{1}{4}$ " or, if $\frac{1}{4}$ " to $\frac{1}{2}$ ", shall be beveled at 50%.
ADASAD 303.3

Section 6 - Boating

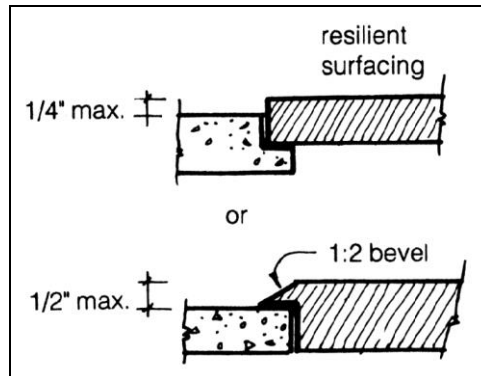

Figure 6-7 Vertical Change in Level and Beveled Change in Level

D. The dock/pier with water fluctuations should post a visual sign reading:

“CAUTION: WATER LEVEL FLUCTUATIONS MAY CAUSE SLOPE CHANGES TO THE GANGWAY. USE CAUTION.”

★ Refer to Section 36 - Signage for design specifications.

Buildings

I. CONCEPT

- A.** Access to buildings shall comply with Chapters 11A, 11B, and all subsections of Title 24 of the California Code of Regulations along with the general requirements of the 2010 ADA Standards for Accessible Design (ADASAD). The code specifies all requirements relating to parking, accessible routes of travel, doorways, clear spaces, reaches, as well as elevators, lifts, stairs, telephones and similar specialized facilities.
- B.** All buildings, or portions thereof, when constructed or renovated, must be accessible. The only exceptions are for portions of floors not customarily occupied, including elevator pits, piping chases, equipment catwalks and machinery rooms.
- C.** In general, if fixed components, such as cabinets, shelves, closets, drawers, counters, sinks and similar apparatus, plus their operating mechanisms and associated controls, dispensers and receptacles are provided in a building, then at least one of each type shall comply with this guideline.
- D.** This section should be used in conjunction with appropriate sections, including restrooms, kitchens, dining areas, etc.
- E.** Please note: These are minimum guidelines only to be used for the purpose of surveying existing buildings and planning for future buildings. The guidelines are incomplete for use in preparing drawings for new or renovated construction. A qualified designer, licensed in the state, knowledgeable in all building codes and the various building occupancy requirements, should be utilized or consulted to ensure compliance with all codes. Access compliance shall also be ensured through consultation with the architects in the Accessibility Section, Acquisition and Development Division. Additionally, State and Federal regulations should be consulted for requirements for all publicly funded buildings.

Section 7 - Buildings

II. ACCESSIBLE ROUTE OF TRAVEL (ART)

- A. For accessible routes of travel exterior to the building:
★ Refer to Section 26 - Parking, Section 32 - Ramps, and Section 34 - Routes of Travel.
- B. When only one accessible route of travel is provided, it shall not pass through kitchens, storage rooms, restrooms, closets or other similar spaces, except within an individual dwelling unit.
CBC 11A-1119A.1
- C. An accessible circulation path is an exterior or interior way of passage from one place to another for pedestrians, including, but not limited to, walks, hallways, courtyards, stairways and stair landings.
ADASAD 106.5
- D. The accessible route, to the maximum extent possible, shall coincide with the route for the general public. Interior accessible routes may include: corridors, floors, ramps, elevators, lifts and clear floor space at fixtures. Vertical access shall include an elevator, lift or ramp.
ADASAD 206.3

III. DOORS AND GATES

- ★ Refer to Section 13 - Doors and Gates.

IV. CLEAR SPACES

- A. In each room, or portion thereof, dedicated to specific functions, there must be an accessible turning space.
CBC 11B-304.1
★ Refer to Section 0.1 - Accessibility Basics, Part IV Turning Space.
- B. There must be a clear space that allows either a forward or parallel approach to building facilities or objects such as counters, appliances, exhibits, etc.
CBC 11B-305.1
★ Refer to Section 0.1 - Accessibility Basics, Part V Clear Floor or Ground Space.

Section 7 - Buildings

- C. If a clear space is located in an alcove, there must be an additional clear space provided.

CBC 11B-305.7

★ Refer to Section 0.1 - Accessibility Basics, Part V Clear Floor or Ground Space, Letter G.

V. AISLES AND CORRIDORS

- A. Every portion of a building shall provide aisles leading to an emergency exit.
- B. Aisles serving one side (e.g., aisles with a blank wall on one side and exhibits/rooms on the other) must be at least 36" wide. Aisles serving both sides (e.g., aisles with exhibits/rooms on both sides) must be at least 44" wide.
- C. If the building occupant load is nine persons or less, the building corridors must be at least 36" wide.
- D. If the building occupant load is ten persons or more, the building corridors must be at least 44" wide.
- E. If a corridor is longer than 200', there must be a passing area at least every 200' measuring a minimum of 60" wide or a T-intersection a minimum of 44" wide for two wheelchairs to pass.

CBC 11B-403.5.3

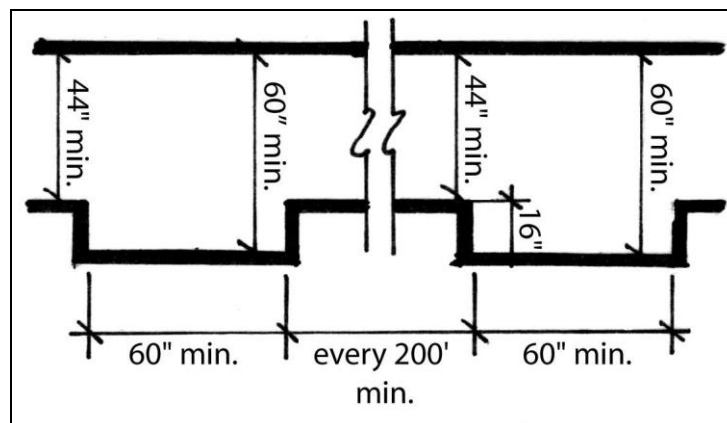

Figure 7-1 Corridor Passing Space

Section 7 - Buildings

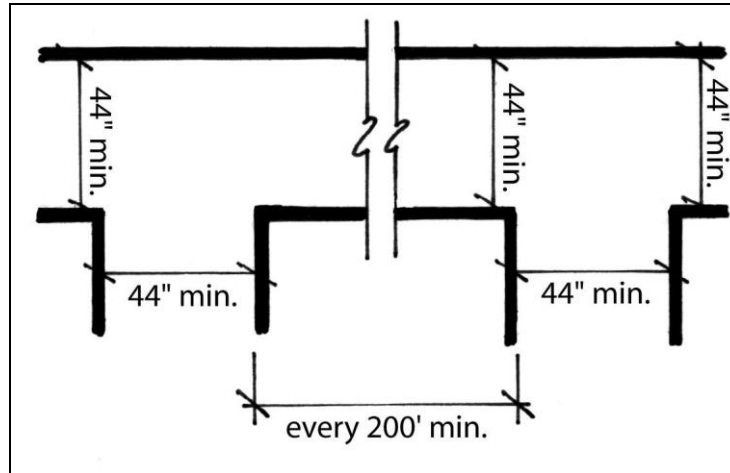

Figure 7-2 Corridor T-Intersection

- F. Where a corridor makes a 180 degree turn around an element which is less than 48" wide, clear width shall be 42" minimum approaching the turn, 48" minimum at the turn and 42" minimum leaving the turn.

CBC 11B-403.5.2

Exception: Where the clear width at the turn is 60" (1525 mm) minimum 36" corridor width is allowed.

CBC 11B-403.5.2 Exception

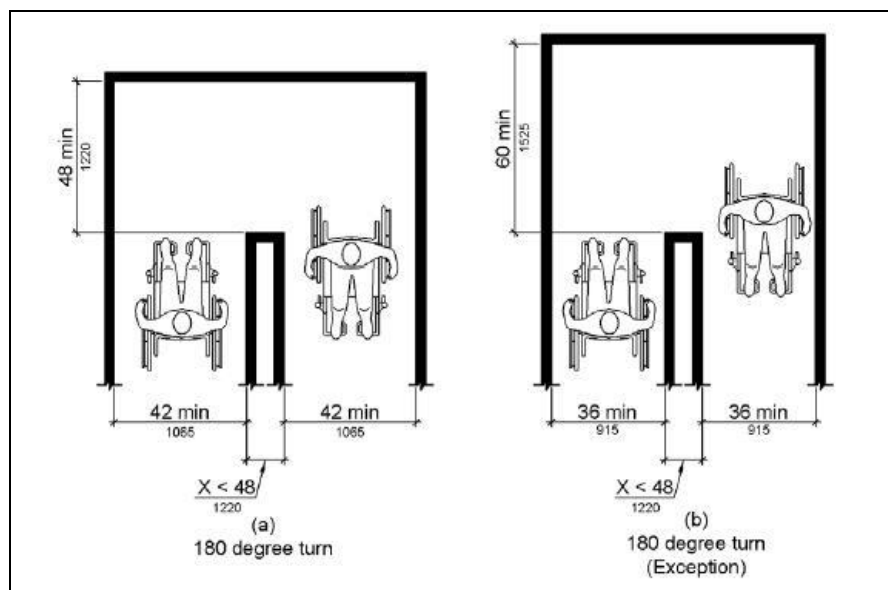

Figure 7-3 Clear Width Around an Element <48" Wide

Section 7 - Buildings

- G.** Where a corridor makes a 180 degree turn around an element which is minimum 48" wide, clear width shall be 36" minimum approaching the turn, 36" minimum at the turn and 36" minimum leaving the turn.

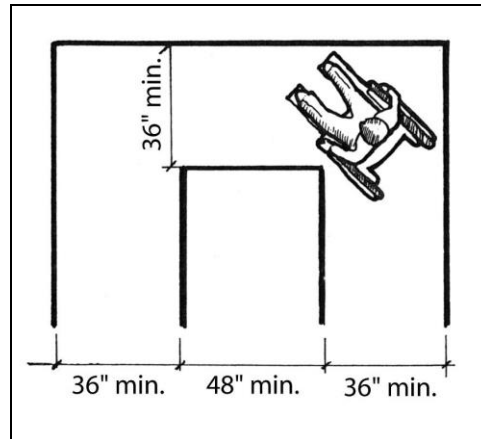

Figure 7-4 Clear Width Around an Element ≥ 48 " Wide

- H.** Objects shall not protrude into aisles or corridors excepted as allowed per ADASAD 307.
★ Refer to Section 0.1 - Accessibility Basics, Part VII Protruding Objects.
- I.** Floors of a single story must be on a common level or connected by a ramp, elevator or access lift.
CBC 11B-206.2.4

VI. REACHES

- ★ Refer to Section 0.1 - Accessibility Basics, Part VIII Reach Range.

VII. FLOORS

- ★ Refer to Section 0.1 - Accessibility Basics, Part II Floor and Ground Surfaces.

Section 7 - Buildings

VIII. OPERATING CONTROLS

★ Refer to Section 0.1 - Accessibility Basics, Part IX Operable Parts.

IX. ELEVATORS

- A. All multi-story buildings must provide access by ramp or elevator.
ADASAD 206.2.3
- B. Changes in levels along an accessible route greater than ½" shall comply with the requirements of a curb ramp, ramp, elevator or platform lift as permitted for new construction or alterations. An accessible route does not include stairs, steps or escalators.
CBC 11B-303.4
- C. Elevators shall be on an accessible route and they shall be designed and constructed to be accessible.
ADASAD 206.6

X. SIGNAGE

- A. For guidelines regarding interior and exterior signs to identify permanent rooms and spaces, and interior and exterior signs to provide direction to or information about spaces refer to the applicable section and Section 36 - Signage.
- B. Signs that are required at doors to exit passageways, exit discharge, and exit stairways shall include both visual and tactile characters that comply with the guidelines found in Section 36 - Signage.
CBC 11B-216.4
- C. When not all building entrances are accessible, then those entrances that are accessible shall be identified by the International Symbol of Accessibility (ISA). Directional signs that indicate the location of the nearest accessible entrance shall be provided at non-accessible entrances. If the route to the accessible entrance diverges from the regular path of travel, directional signs with the ISA shall be placed at route junctions.
CBC 11B-216.6
★ Refer to Section 36 - Signage for design specifications.

Section 7 - Buildings

- D. Where existing elevators are not accessible, elevators that are accessible shall be clearly identified with the International Symbol of Accessibility (ISA). Existing buildings that have been remodeled to provide specific elevators for public use that are accessible shall have the location of and the directions to these elevators posted in the building lobby on a sign that includes the ISA.

CBC 11B-216.7

★ Refer to Section 36 - Signage for design specifications.

Campfire Centers & Assembly Areas

I. CONCEPT

- A.** Campfire centers and other assembly areas, including theaters, stages and spaces used by performers, are provided to enhance park visitor experiences through education, entertainment or a variety of other needs. Facilities must be fully accessible to visitors and employees. All campfire centers and other assembly areas, as well as facilities therein, shall be constructed or renovated, taking into account the path of travel and any ramp requirements.

ADASAD 802

★ Refer to Section 34 - Routes of Travel.

II. SEATING

- A.** Accessible seating shall be distributed throughout the area to provide a choice of sight lines.

ADASAD 221.2.2-3, 802.2

- B.** Each accessible seating area shall have spaces for companion seating, and be located on an accessible route that also serves as an emergency accessible exit.

ADASAD 221.3

- C.** Wheelchair spaces shall be horizontally and vertically dispersed where there are more than 300 seats. Where there are 300 seats or less:

1. Horizontal dispersion shall not be required if wheelchair spaces and companion seating are located in the 2nd or 3rd quartile of the total row length.
2. Vertical dispersion shall not be required if the wheelchair spaces provide viewing angles that are equivalent to, or better than, the average viewing angle.

ADASAD 221.2.3.1-2

Section 8 - Campfire Centers & Assembly Areas

- D. Seating requirements shall comply with Table 8-1:
 ADASAD 221.4

Table 8-1 Wheelchair Seating Requirements

Seating Capacity	Number of Required Wheelchair Locations
4 to 25	1
26 to 50	2
51 to 150	4
151 to 300	5
301 to 500	6
501 to 5000	6, plus 1 for each 150 or fraction thereof, between 501 through 5000

- E. At least 5 percent of the total number of aisle seats provided shall comply with items 1 and 2 below and shall be the aisle seats located closest to accessible routes.

ADASAD 221.4

1. Where armrests are provided on the seating in the immediate area, folding or retractable armrests shall be provided on the aisle side of the seat.

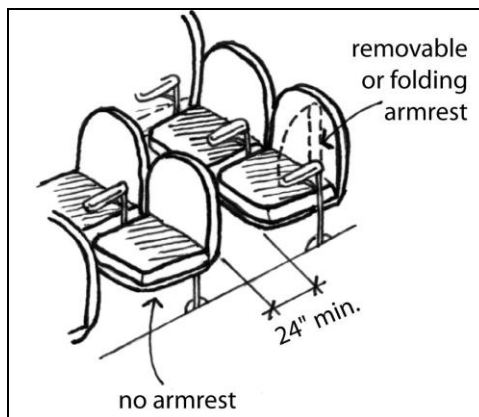

Figure 8-1 Retractable Armrest on Aisle Seat

2. Each designated aisle seat shall be identified by a sign or marker with the ISA on it.

ADASAD 802.4

Section 8 - Campfire Centers & Assembly Areas

- F. A single wheelchair space shall be 36 inches wide minimum. Where two adjacent wheelchair spaces are provided, each wheelchair space shall be 33 inches wide minimum.

ADASAD 802.1.2

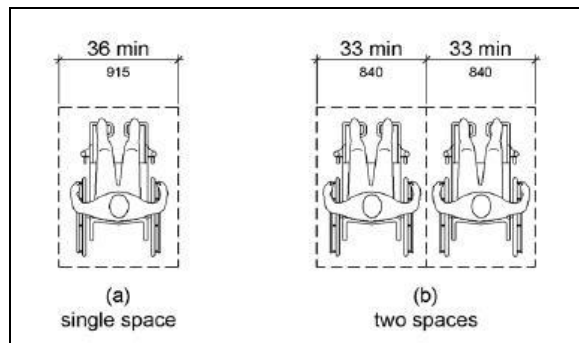

Figure 8-2 Width of Wheelchair Spaces in Campfire & Assembly Areas

- G. Where a wheelchair space can be entered from the front or rear, the wheelchair space shall be 48 inches deep minimum. Where a wheelchair space can be entered only from the side, the wheelchair space shall be 60 inches deep minimum.

ADASAD 802.1.3

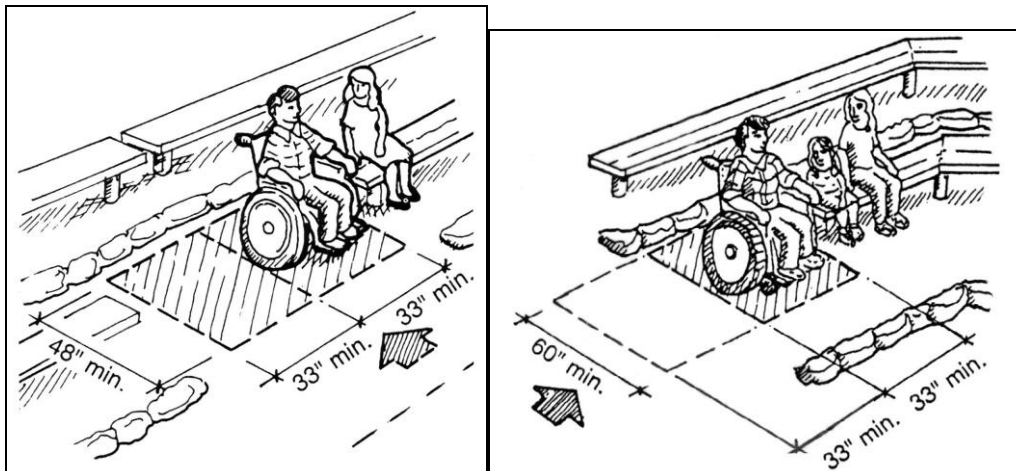

Figure 8-3 Depth of Wheelchair Spaces in Campfire & Assembly Areas

- H. When seating locations are not in the front row, a clear line of sight must be provided from the wheel chair location to the performance area.

ADASAD 802.2

Section 8 - Campfire Centers & Assembly Areas

- I. Semi-ambulant seating shall be provided of up to 1% of the total, but no less than two. Semi-ambulant seats shall have a minimum of 24" of leg clearance measured from the front edge of the seat to the backrest of the seat immediately in front or nearest obstruction (**Figure 8-1**).
CBC 11B-221.6
- J. Armrests and backrests required with fixed bench seating are not mandatory in a spectator assembly environment.
CBC 11B-221.4 Exception

III. PATH OF TRAVEL

- A. At least one accessible route within the boundary of the site shall be provided from public transportation stops, accessible parking and accessible passenger loading zones, as well as public streets or sidewalks to the accessible entrance they serve.
ADASAD 206.2.1
- B. The minimum clear width of an accessible route shall be 36", except at doorways, which may be 32".
ADASAD 403.5.1
★ Refer to Section 13 - Doors and Gates.

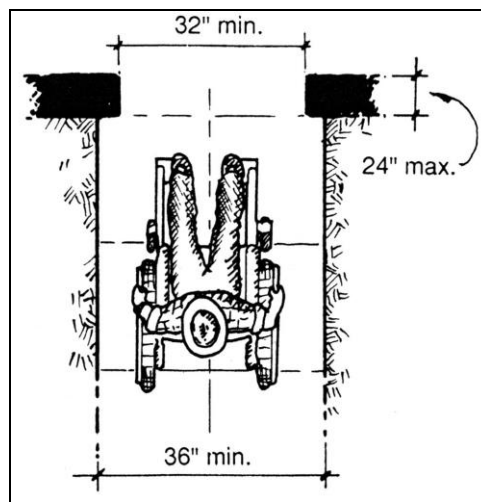

Figure 8-4 Minimum Clear Width at a Doorway

Section 8 - Campfire Centers & Assembly Areas

- C.** An accessible route shall connect wheelchair-seating locations with performing areas, including stages and other spaces used by presenters.
ADASAD 206.2.6

IV. LIGHTING

- A.** The minimum level of lighting at the floor or ground level of campfire centers and assembly areas, whether indoors or outdoors, shall not be any less than 1 foot-candle. This is the minimum level of lighting required for safe egress in case of emergency.

V. LISTENING SYSTEMS

- A.** Assistive listening systems shall be provided in each public assembly area where audible communication is integral to the use of the space.
ADASAD 219.2
★ Refer to Section 2 - Assistive Listening Systems.

Camping

I. GENERAL

- A. Where camping (tent sites, RV or trailer sites, cabin, tent platform or other camping shelter sites) is provided, the minimum number of accessible sites to be provided for each type of site shall comply with **Table 9-1**.

AGODA F244.2

Table 9-1 Accessible Campsite Requirements

Number of Campsites	Number of Accessible Campsites
1	1
2 to 25	2
26 to 50	3
51 to 75	4
76 to 100	5
101 to 150	7
151 to 200	8
201 and over	8, plus 2 percent of the number over 200

1. In addition to these accessible camp sites, camp host sites must be accessible.
2. Cabins and yurts are not camping shelters and must follow the guidelines as specified in *Section 14 - Dormitories, Hotels & Seasonal Lodging*.

- B. For the convenience of all users, Department policy dictates that when replacing campground furnishings such as tables, food lockers and barbeques, these furnishings shall be of an accessible design.

DN 95-32

- C. All elements of an accessible site shall be accessibly designed. In addition, there shall be accessible routes from the campsite to its own parking, utilities, site furnishings, an accessible restroom and, if present, a campfire center.

AGODA F244.5.1-2

Section 9 - Camping

II. PARKING SPACES

- A. Parking space dimensions shall comply with **Figure 9-1**. Slope shall not exceed 2%. Except when the surface is other than asphalt, concrete, or boards, slopes not steeper than 5% may be permitted where necessary for drainage. The surface shall be firm and stable.

AGODA 1012.1-1012.5

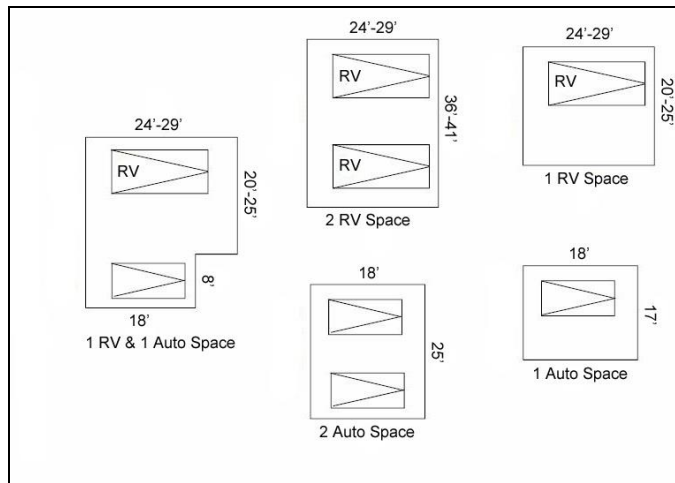

Figure 9-1 Accessible Parking Space Dimensions for Campsites

- B. Parking spaces shall be adjacent to campsites or picnic areas in compliance with **Figure 9-2**.

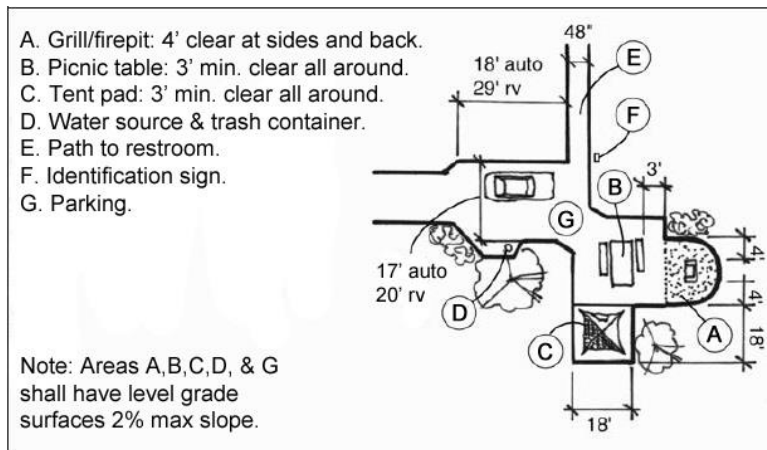

Figure 9-2 Accessible Tent Campsite Design

Section 9 - Camping

III. RV CAMPING

A. Hook-ups and campsite furniture shall be accessibly designed.

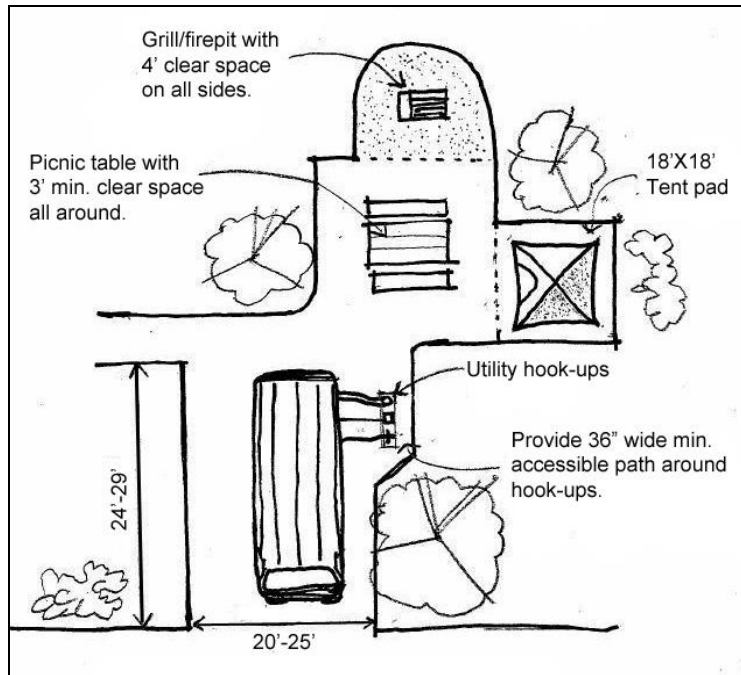

Figure 9-3 Accessible RV Campsite Design

B. In existing designated RV camping spaces the minimum width shall be 20' wide with a recommended length of 24'. Where possible, the optimum goal is a 25' wide space.

Tucker vs. California State Parks, November 2005.

C. RV spaces in newly constructed campgrounds shall be a minimum of 23' wide with a goal of 25' wide, or the space will be adaptable to create at least a 23' to 25' wide space.

D. RV spaces wider than 20' will have the specific width designated on the reservation system.

E. The slope of RV spaces shall not exceed 2%. Except when the surface is other than asphalt, concrete, or boards, slopes not steeper than 5% may be permitted where necessary for drainage. The surface shall be firm and stable.

AGODA 1012.4-5

Section 9 - Camping

- F. If an accessible pull-through campsite is provided, then the pull-through area shall be a minimum 20' wide for the entire length. Where possible, the optimum goal is a 25' wide space.

AGODA 1012.2

IV. SITE PLANNING

- A. Accessible sites shall represent the range of sites in the campground (e.g., water view, secluded, etc.).

AGODA F244.2.2

- B. If tent sites are provided, they should have an 18' x 18' firm, but not paved, tent/sleeping pad adjacent to table/cooking area. Camp and tent site slope shall not exceed 2%; if needed for proper drainage, when the surface is other than asphalt, concrete, or boards, slopes not steeper than 5% may be permitted where necessary for drainage. **(Figure 9-2)**

AGODA 1013.3

- C. If tent sites are provided, the ground must be firm and stable, and designed to allow the use of tent stakes.

AGODA 1013.2.2

- D. Where an 18' x 18' raised tent platform is provided, the platform shall be 19" high maximum measured from the clear ground space to the tent platform surface.

AGODA 1013.4

V. PICNIC TABLES

- A. Picnic tables shall have a minimum 36" clear width of firm surface area all around. Trash receptacles, barbecues, etc. shall not encroach on this space.

AGODA 1011.2.1

Section 9 - Camping

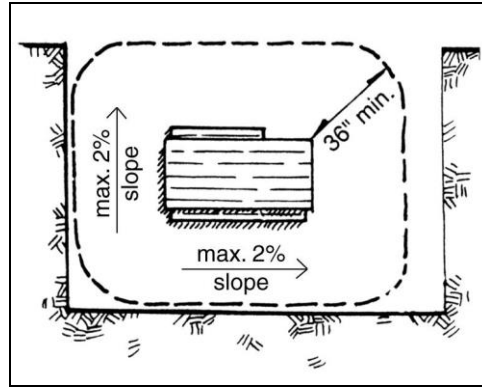

Figure 9-4 Clear Space around Picnic Tables and Max Slope

- B. The maximum slope around the picnic table shall not exceed 2%; 5% is acceptable for proper drainage.
AGODA 1011.2.3
- C. Picnic tables and benches shall have rounded corners with no sharp edges or protruding hardware, such as bolts.
- D. The distance from the ground to the tabletop work surface shall be between 28" and 34" (32" recommended).
ADASAD 902.3

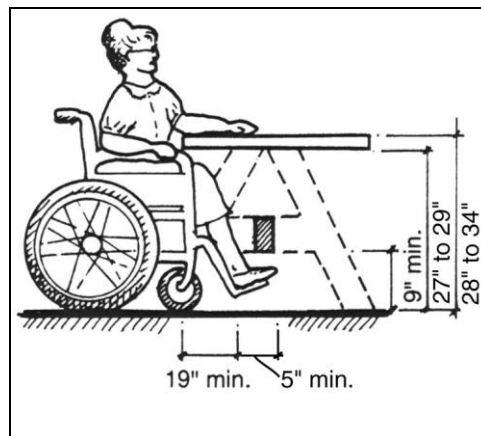

Figure 9-5 Picnic Table Clearances

- E. Tables shall have a 27" minimum knee clearance from surface grade (29" clearance is recommended). **(Figure 9-5)**
ADASAD 902.2, 306

Section 9 - Camping

- F. Picnic tables shall have a 19" clear horizontal knee space under the table. Toe clearance 9" min. in height shall extend an additional 5" min. from the knee clearance. Table anchors may not encroach on clear space. **(Figure 9-5)**

ADASAD 902.2, 306

- G. Tables shall have at least one 30" wide clear space beneath the table for each 24 linear feet of usable table surface perimeter.

AGODA 1011.4

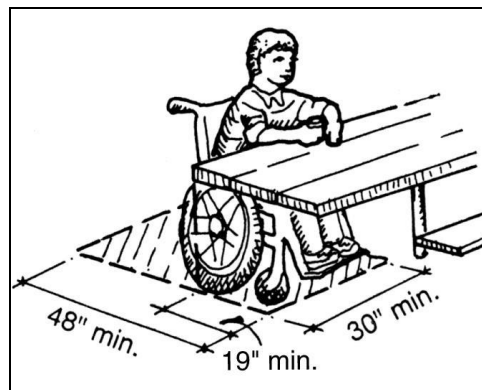

Figure 9-6 Clear Space under Picnic Table

VI. GRILLS, FIRE RINGS AND FIREPLACES

- A. Grills, fire rings and fireplaces shall be placed so there is a minimum 48" clear space (360°) surrounding the cooking facility.

AGODA 1011.2.1

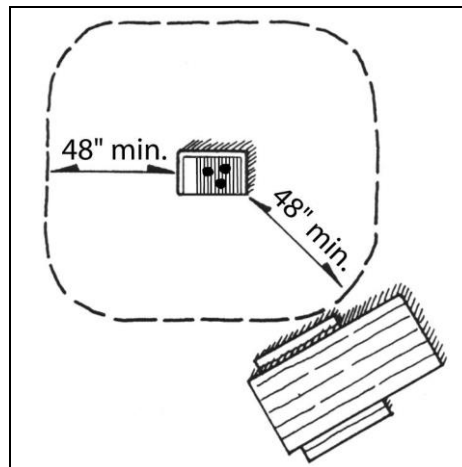

Figure 9-7 Clear Space around Grills, Fire Rings, and Fireplaces

Section 9 - Camping

B. Grills, fire rings, etc. shall be surrounded by a firm, stable ground surface. A firm surface is one which does not give way significantly under foot and resists indentation from a person's foot, wheelchair or other assistive mobility device.
AGODA 1011.2.2

C. The maximum slope of the clear space surrounding grills, fire rings, etc. shall be 2%, with 5% allowed for drainage.
AGODA 1011.2.3

D. In accessible, developed campground sites and picnic areas where concrete or other hard surface paving exists or is to be installed, a detectable warning shall be provided around the grill, fire ring, etc. to alert blind and visually impaired persons to the location of the grill, fire ring, etc. This warning surface will have a minimum depth of 24" and shall provide clear visual contrast from the immediate adjoining surfaces.

Re: Tucker vs. California State Parks, November 2005.

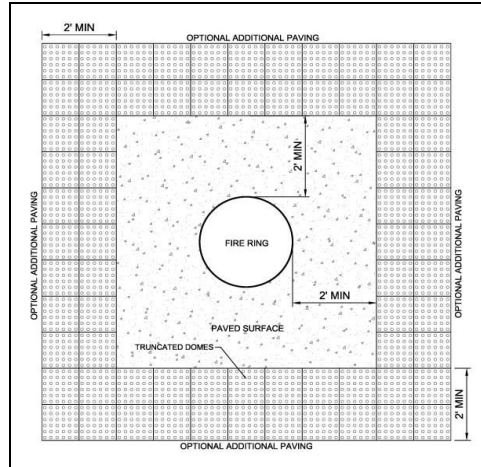

Figure 9-8 Warning Surface around Grill, Fireplace or Fire Ring

E. When the grill is built into a fireplace, the grill shall be between 15" and 34" above the ground. The fire-building surface shall be minimum 9" from the ground.
AGODA 1011.5.1-2

Section 9 - Camping

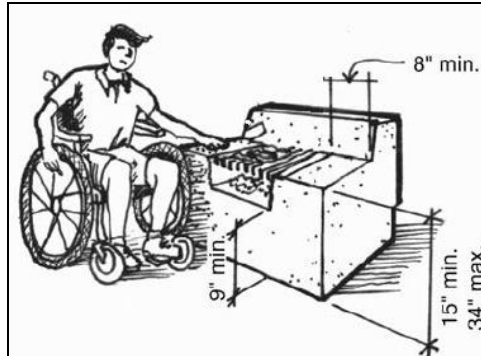

Figure 9-9 Grill/Fireplace Dimensions

- F. It is recommended that grills and fireplaces have an adjacent horizontal surface at least 8" wide on which hot objects may be placed. The height of this work surface shall follow the guidelines for tables/counters found in Section 12 - Dining & Banquet Areas. **(Figure 9-9)**
- G. The cooking surface of post-mounted grills shall be between 15" and 34" above grade, with unobstructed access by horizontal reach from a standing or seated position.

AGODA 1011.5.2

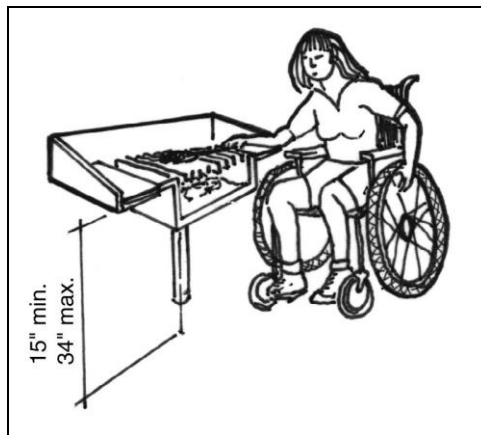

Figure 9-10 Post-Mounted Grill Height Range

- H. The fire building surface of a fireplace or fire ring must be at least 9" from the ground.
- AGODA 1011.5.1

Section 9 - Camping

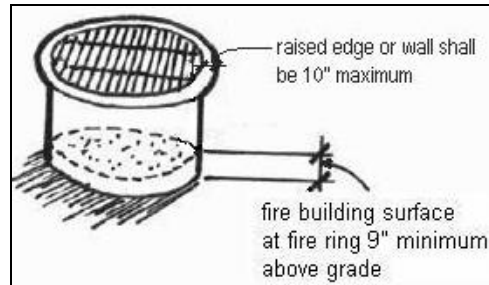

Figure 9-11 Fire Ring Surface Minimum Height

- I. Where a raised edge or curb is provided on a fire ring, the thickness of the outside edge or curb of the fire ring shall not exceed 10". (Figure 9-11)
AGODA 1011.5.3

VII. WATER FAUCETS

- A. Faucets shall be located adjacent to a clear, stable, firm ground surface area at least 48" x 72" in size. Rock surfaces are not allowed. Faucets shall be configured to allow a forward approach.
AGODA 1011.2.1

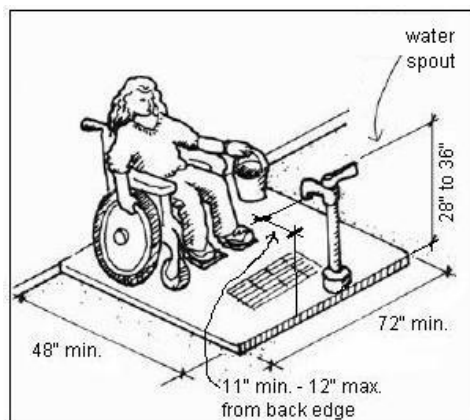

Figure 9-12 Water Faucet Placement

- B. A 2% slope shall be allowed to drain toward the faucet drain. When the surface is other than asphalt, concrete, or boards, slopes not greater than 5% may be used for drainage. Drain grating shall have a maximum opening of $\frac{1}{2}$ ".
AGODA 1011.2.3-4

Section 9 - Camping

- C. The water spout shall be located 28" to 36" above the ground and shall be operated by a push button or lever actuator that requires no more than 5 lbs. of pressure to operate and is located within prescribed reach ranges.

AGODA 1011.6, 1011.3

★ Refer to Section 0.1 - Accessibility Basics, Part VIII Reach Range.

VIII. TRASH RECEPTACLES AND FOOD LOCKERS

- A. Trash receptacles and food lockers shall be located on an access route from the campsite. (Figure 9-2)

AGODA 1011.2.1

- B. Trash receptacle openings shall be located 15" to 48" above the ground.

AGODA 1011.3

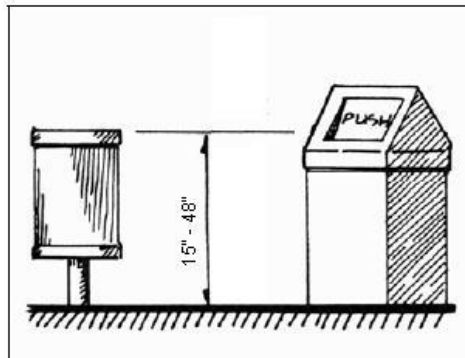

Figure 9-13 Trash Receptacle Opening Height

- C. If so equipped, both outdoor and indoor (e.g., restrooms) trash receptacles shall operate with a single hand manipulation requiring no more than 5 lbs. of pressure.

AGODA 1011.3

- D. Where necessary for health and safety reasons, animal exclusion receptacles that do not meet this guideline may be used.

AGODA 1011.3

- E. There shall be a minimum 36" x 48" clear space positioned for a forward approach or a 30" x 60" clear space positioned for a parallel approach to the receptacle opening. The maximum slope of the clear space shall be 2%, when

Section 9 - Camping

the surface is other than asphalt, concrete, or boards, slopes not steeper than 5% are acceptable for proper drainage. Surface shall be firm and stable.

AGODA 1011.2.1-3

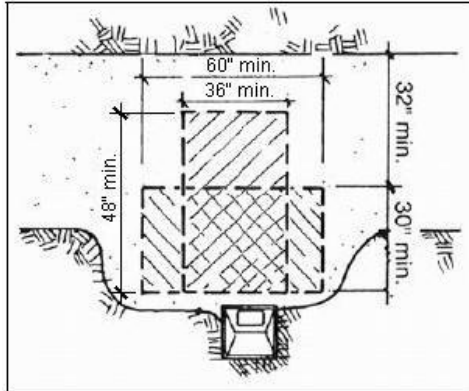

Figure 9-14 Trash Receptacle Clear Space

- F. Food lockers shall have a clear approach that provides a 30" x 48" clear space. The latching mechanism shall be mounted between 15" and 48". The latch shall be operable with one hand and not require tight grasping, pinching or twisting.

IX. SIGNAGE

- A. Accessible campsites shall be designated by the placement of a small International Symbol of Accessibility (ISA) directly under the campsite number.
DOM 2607.8
★ Refer to Section 36 - Signage for design specifications.

Concessions

I. CONCEPT

- A.** All concessions in State Parks must provide access for visitors with disabilities.
- B.** Concession operators are responsible to remove physical barriers to accessibility at the facilities they operate and to provide access to the programs and services they offer.
- C.** Districts are responsible to monitor concessionaire progress toward achieving accessibility compliance.

II. GENERAL

- A.** All new concessions, whether in a new or existing facility, shall be fully access compliant prior to beginning operations.
- B.** All existing concessionaires shall actively pursue barrier removal utilizing the approval processes described in their concession contract.
- C.** All new concessionaires that take over operation of an existing non-complaint concession must remove all barriers to access within one year of beginning operations.
- D.** Districts shall ensure that construction projects undertaken by concessionaires are reviewed for compliance by the Accessibility Section, utilizing the construction project review process found in DOM 2608.1.
- E.** Activities offered by concessions, such as but not limited to, walking tours, equipment rentals, and educational programs, must provide access or equivalent facilitation to ensure opportunities for equal participation by people with disabilities.
- F.** Service machines used in concessions, including fee collection machines, vending machines, and interactive computers, must comply with appropriate standards.
 - ★ Refer to Section 35 - Service Machines for more information.

Section 10 - Concessions

III. COMPLIANCE

- A. All concessions contracts held by the Department will be in compliance with accessibility standards established by Federal, State, and Department mandates. All new or renewed concession contracts must include the following paragraphs:

“Without limiting Concessionaire’s responsibility under this contract for compliance with all laws, with regard to all operations and activities that are the responsibility of Concessionaire under this contract, Concessionaire shall be solely responsible for complying with the requirements of the Americans With Disabilities Act of 1990 (ADA) (Public Law 101 336, commencing at Section 12101 of Title 42, United States Code; and including Titles I, II, and III of that law) and the Rehabilitation Act of 1973, and all related regulations, guidelines, and amendments to both laws.”

“With regard to facilities for which Concessionaire is responsible for operation, maintenance, construction, restoration, or renovation under this Contract, Concessionaire also shall be responsible for compliance with Government Code Section 4450, et seq., Access to Public Buildings by Physically Handicapped Persons, and Government Code Section 7250, et seq., Facilities for Handicapped Persons, and any other applicable laws. Written approval from State is required prior to implementation of any plans to comply with accessibility requirements. These facilities must be compliant with the 2010 ADA Standards for Accessible Design, California Building Code, Title 24 Chapter 11B (latest edition), Accessibility to Public Accommodations, and the Final Accessibility Guidelines for Outdoor Developed Areas put forth by the United States Access Board.”

Curb Ramps

I. GENERAL

- A. Curb ramps are part of an accessible route of travel. They are required to be located at pedestrian crosswalks wherever the accessible route of travel requires the pedestrian to transition from, through, or onto a raised curb.

CBC 11B-406.1

★ Refer to Section 34 - Routes of Travel.

- B. Curb ramps may be parallel, perpendicular, or a combination of parallel and perpendicular.

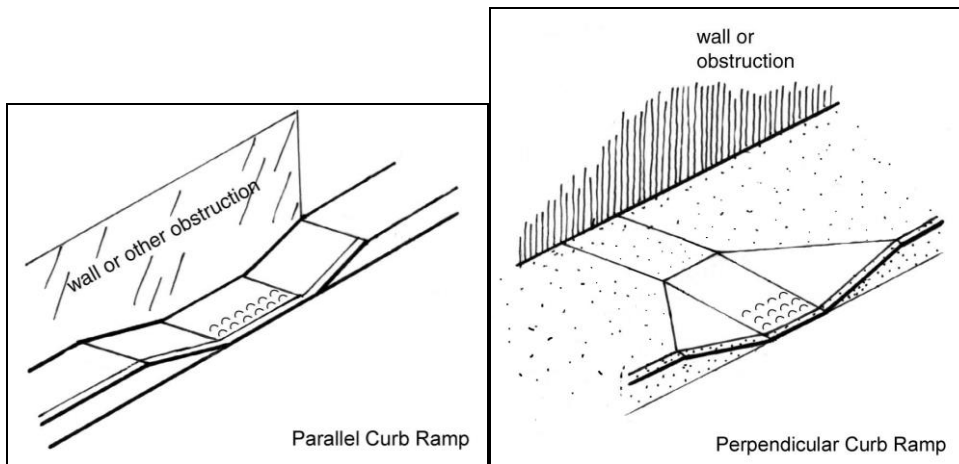

Figure 11-1 Parallel & Perpendicular Curb Ramps

- C. Curb ramps (and any flared sides) shall be located so that they do not project into vehicular traffic lanes, parking spaces, or parking access aisles.

CBC 11B-406.5.1

- D. Wherever vehicular surfaces are marked for a pedestrian crosswalk, the curb ramp must terminate within the crosswalk area (excluding any flared sides).

CBC 11B-406.5.1

Section 11 - Curb Ramps

II. GUIDELINES

- A. The clear width of any curb ramp, excluding any flared sides, shall be 48" minimum.

CBC 11B-406.5.2

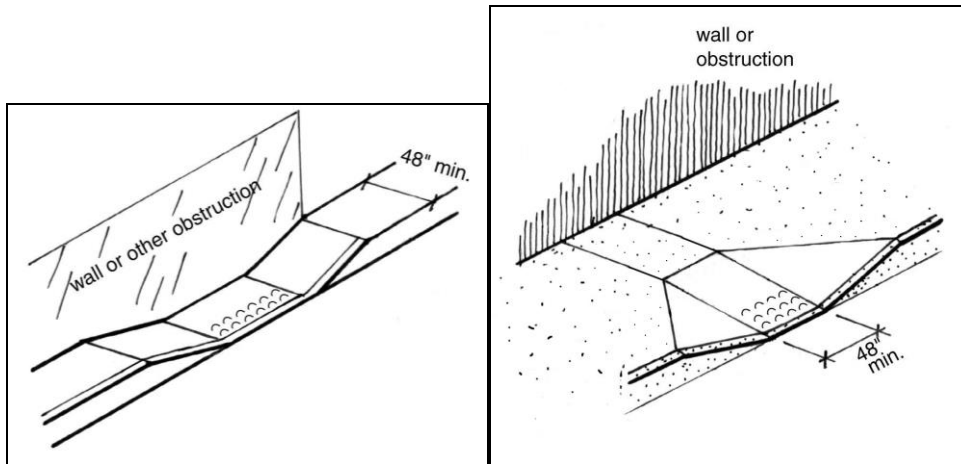

Figure 11-2 Curb Ramp Minimum Width

- B. The maximum running slope of any curb ramp shall be 8.33%; maximum cross slope shall be 2%.

CBC 11B-406.2.1, 406.3.1, 406.5.7

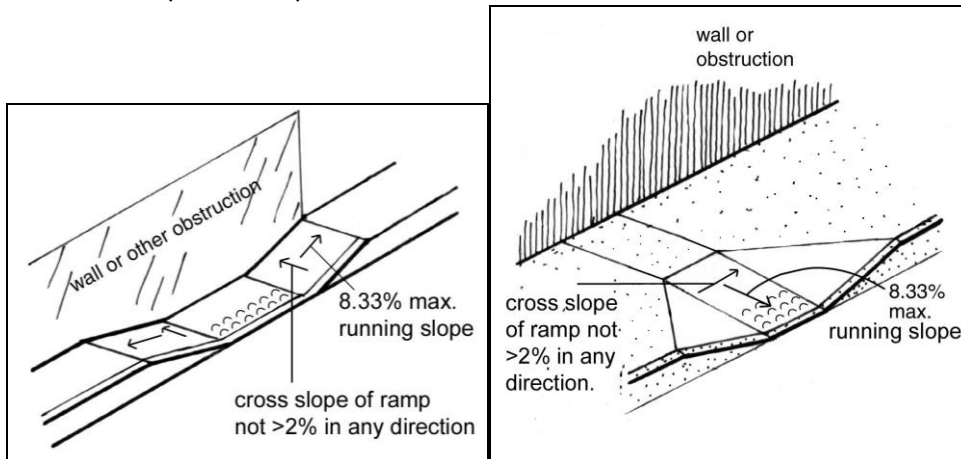

Figure 11-3 Curb Ramp Maximum Running Slope & Maximum Cross Slope

- C. Where flared sides are installed to adjoin the curb ramp, the maximum slope of the flared sides shall be 10%.

CBC 11B-406.2.2

Section 11 - Curb Ramps

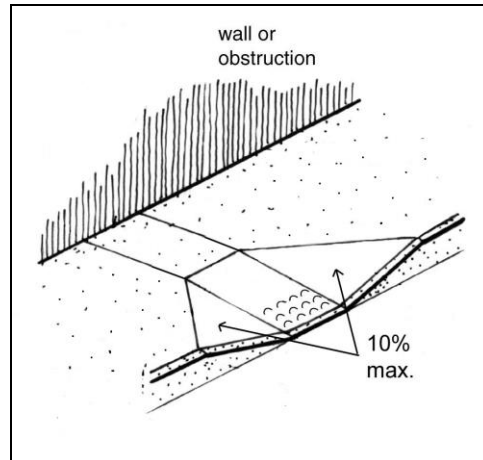

Figure 11-4 Curb Ramp Flared Side Maximum Slope

- D. A level landing shall be provided at the top of curb ramps. The landing clear length shall be 48" minimum. The landing clear width shall be at least as wide as the curb ramp, excluding any flared sides leading to the landing. The slope of the landing in all directions shall be 2% maximum.

CBC 11B-406.5.3

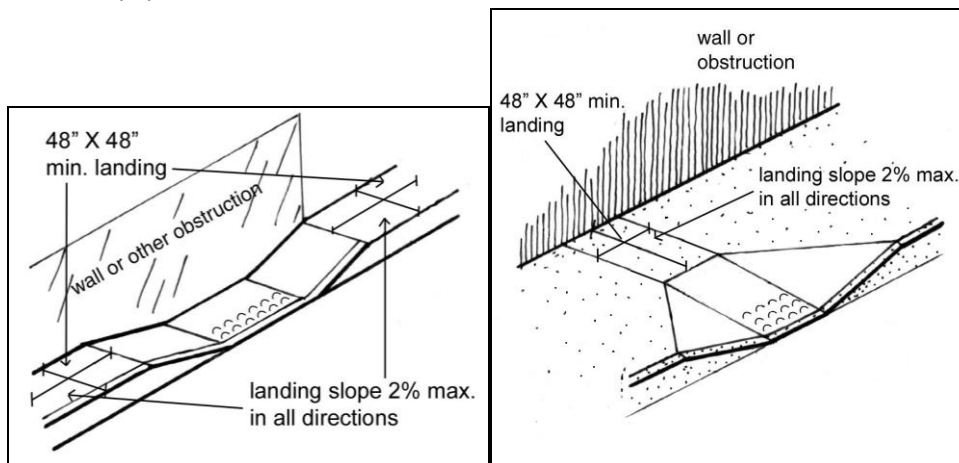

Figure 11-5 Curb Ramp Landing

- E. The slope of the adjoining gutters, road surfaces and the accessible route at either end of the curb ramp shall have a maximum slope of 5% for a minimum run of 48".

CBC 11B-406.4.1

- F. The surface of the curb ramp and its flared sides shall be stable, firm, and slip resistant.

CBC 11B-406.5.4

Section 11 - Curb Ramps

III. DETECTABLE WARNINGS

- A. Curb ramps shall have a detectable warning in the form of truncated domes with an in-line grid pattern that extends the full width and 3' deep in the direction of the ramp run. Domes shall be in a color that contrasts with the surrounding surface. For additional information, ☎ contact the Accessibility Section.

CBC 11B-406.5.12

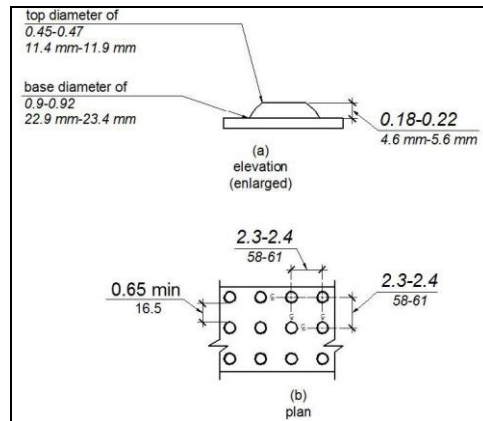

Figure 11-6 Size and Spacing of Truncated Domes

IV. DIAGONAL RAMPS

- A. Well-defined edges of diagonal (corner type) ramps shall be parallel to the direction of traffic flow.

CBC 11B-406.5.10

- B. There shall be a 48" minimum clear space at the bottom of diagonal curb ramps. The clear space must be located within the marked crossing, if marked crossings are provided.

CBC 11B-406.5.9

- C. Where provided, flared sides on the diagonal curb ramps shall have 24" long segments of straight curb on each side of the curb ramp. The flared sides shall be within the marked crossing.

CBC 11B-406.5.10

Section 11 - Curb Ramps

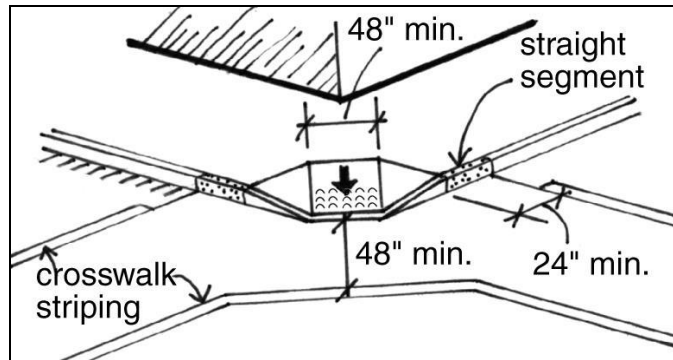

Figure 11-7 Diagonal Ramp Requirements

V. ISLANDS

- A. If an island exists there shall be either an accessible 60" wide minimum path cut through the island at street level, or curb ramps on both sides of the island with a 48" wide level area in between.

CBC 11B-406.6

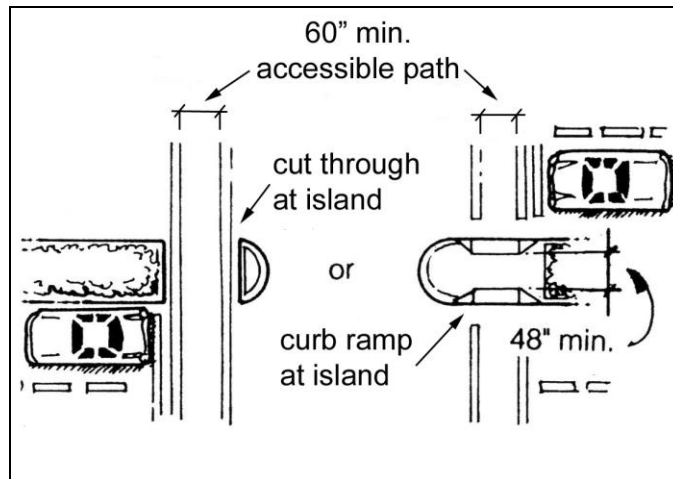

Figure 11-8 Islands in Crossings

Dining & Banquet Areas

I. CONCEPT

- A.** Dining and banquet facilities shall be made accessible to persons with disabilities, including food service and sales counters, with appropriate seating and wheelchair seating integrated throughout.
- B.** There shall also be an accessible route of travel to and from the dining/banquet area.
ADASAD 206.1
★ Refer to Section 34 - Routes of Travel.

II. SEATING

- A.** Wheelchair access shall be provided to all areas. Each dining or banquet area shall have one wheelchair seating for every 20 seats where each type of functional activity occurs, with at least one wheelchair seating space per functional area.
CBC 11B-226.1
★ Refer to Section 7 - Buildings.
- B.** Access to such seating shall be provided with main aisles no less than 36" in clear width. Accessible seating shall be integrated with general seating to allow a reasonable selection of seating areas and to avoid having one area specifically highlighted as the area for person with disabilities.
ADASAD 206.2.4, 226.2, 802.1.2

Section 12 - Dining & Banquet Areas

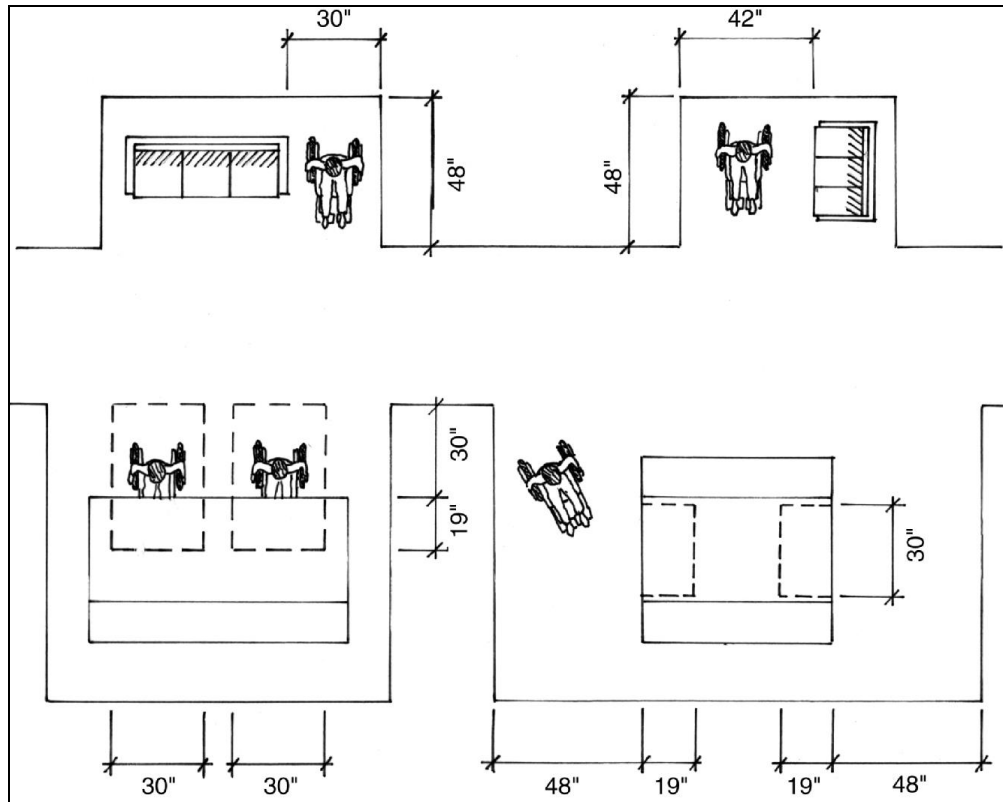

Figure 12-1 Wheelchair Seating in Dining & Banquet Areas

III. KNEE CLEARANCE

- A. Knee space at tables and counters shall be a minimum of 27" high (recommended 29"), 30" wide and 19" deep.
CBC 11B-902.2
- B. Knee clearance is not required at a checkout counter or service counter as long as there is a clear floor space to allow for a parallel approach.
CBC 11B-904.4.1

Section 12 - Dining & Banquet Areas

IV. HEIGHT OF TABLES / COUNTERS

- A. The tops of accessible tables and counters shall be 28" minimum to 34" maximum above the floor or ground. Where a single counter contains more than one transaction, at least 5% of those transactions, but not less than one, shall comply with **Figure 12-2**.

CBC 11B-902.3

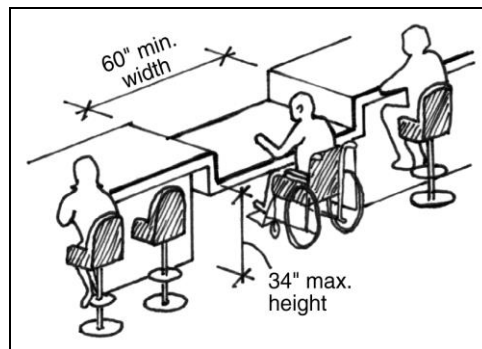

Figure 12-2 Accessible Table Top

- B. Food service aisles shall be a minimum of 36" of clear width with a preferred width of 42" where passage of stopped wheelchairs by pedestrians is desired. Tray slides shall be mounted no higher than 34" above the floor, if self-service.

ADASAD 206.2.5

CBC 11B-904.5.2

V. REACH

- A. Clear Floor Space

★ Refer to Section 0.1 - Accessibility Basics, Part V Clear Floor or Ground Space & Part VI Knee and Toe Clearance.

- B. Tableware, dishware, condiments, food, beverage shelves and dispensing devices shall be located within accessible reach ranges.

★ Refer to Section 0.1 - Accessibility Basics, Part VIII Reach Ranges.

Doors and Gates

I. CONCEPT

- A.** Doors and gates are an integral part of the route of travel and should be considered for accessibility whether they are on interior building routes or on exterior routes. Doors and gates are also used as emergency exits and shall be accessible as part of the evacuation plan for the facility.

II. ACCESS ROUTES

- A.** All entrances and exterior ground floor exit doors shall be accessible. During periods of partial or restricted use, doorways that are primary entrances shall be accessible.
CBC 11B-404.1
- B.** Revolving doors, revolving gates, and turnstiles shall not be part of an accessible route.
CBC 11B-404.2.1

III. SURFACES

- A.** Floor or ground surface within required maneuvering clearances shall not slope more than 2%. With the exception of at thresholds, changes in level are not permitted.
CBC 11B-404.2.4.4

IV. CLEARANCES

- A.** Minimum maneuvering clearances at doors and gates shall comply with this section. Maneuvering clearances shall extend the full width of the doorway and the required latch side or hinge side clearance.
- B.** Swinging doors and gates shall have maneuvering clearances complying with **Table 13-1**.
CBC 11B-404.2.4.1

Section 13 - Doors and Gates

Table 13-1 Maneuvering Clearances at Manual Swinging Doors and Gates

Type of Use		Minimum Maneuvering Clearance	
Approach Direction	Door or Gate Side	Perpendicular to Doorway	Parallel to Doorway (beyond latch side unless noted)
From front	Pull	60 inches (1524 mm)	18 inches (457 mm) *5
From front	Push	48 inches (1219 mm)	0 inches (0 mm) *1
From hinge side	Pull	60 inches (1524 mm)	36 inches (914 mm)
From hinge side	Pull	60 inches (1524 mm)	44 inches (1118 mm)
From hinge side	Push	44 inches (1118 mm) *2	22 inches (559 mm) *3
From latch side	Pull	60 inches (1524 mm)	24 inches (610 mm)
From latch side	Push	44 inches (1118 mm) *4	24 inches (610 mm)

1. Add 12 inches (305 mm) if closer and latch are provided.
2. Add 4 inches (102 mm) if closer and latch are provided.
3. Beyond hinge side
4. Add 6 inches (152 mm) if closer is provided.
5. Add 6 inches (152 mm) at exterior conditions.

- C. The clear opening of doorways shall be no less than 32". Floor or ground surface within required maneuvering clearances shall not slope more than 2%. With the exception of at thresholds, changes in level are not permitted.
CBC 11B-404.2.3

- D. If the depth of the doorway opening is greater than 24", there must be a minimum aisle width of 36".
CBC 11B-404.2.3

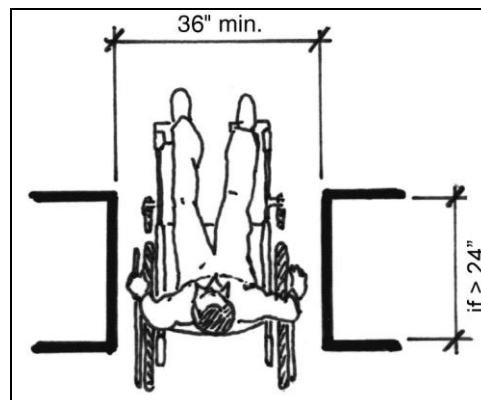

Figure 13-1 Minimum Clear Width, Opening Greater than 24" Deep

Section 13 - Doors and Gates

- E. There must be a level, clear area on both sides of the door measuring 60" in the direction of the door swing (swing side) and 48" opposite the direction of the door swing (non-swing side), measured at right angles to the plane of the door when closed. The level clear space must be as wide as the door plus a required strike edge clearance space. Strike edge clearance is the clear space at the latch side of the door. Strike edge clearance varies with the type of door and approach as shown in **Table 13-1**.

CBC 11B-404.2.4.1

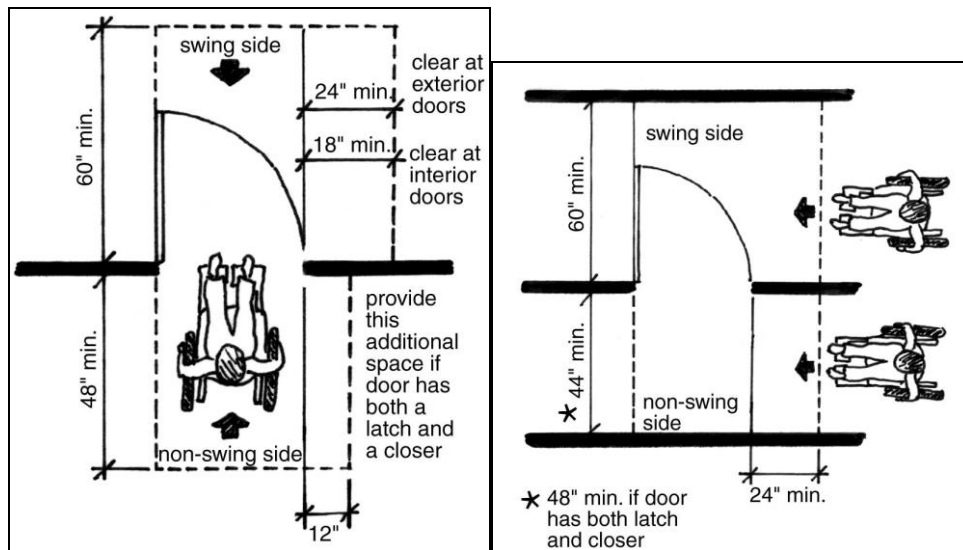
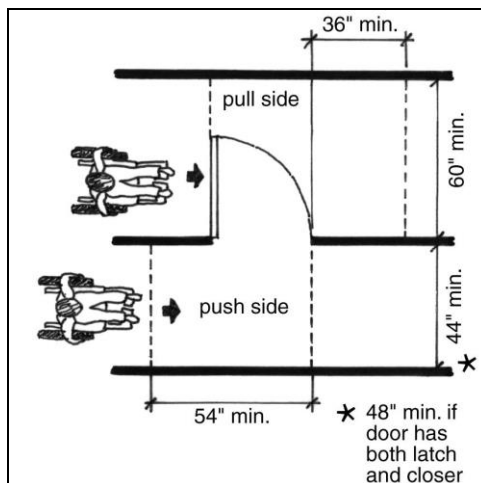

Figure 13-2 Maneuvering Clearances at Manual Swinging Doors and Gates



**Figure 13-2 -- continued
Maneuvering Clearances at Manual Swinging Doors and Gates**

Section 13 - Doors and Gates

- F. For recessed doors, where the plane of the doorway is offset 8" or more from any obstruction within 18", measure laterally on latch side, the door shall be provided with maneuvering clearance for front approach.

CBC 11B-404.2.4.3

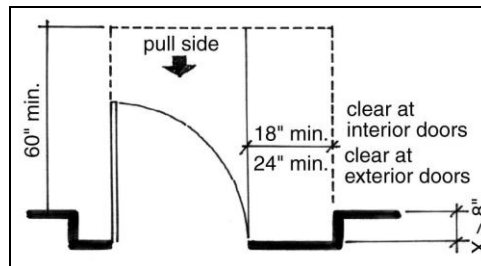

Figure 13-3 Maneuvering Clearances at Recessed Doors and Gates

V. THRESHOLDS

- A. Thresholds shall have a maximum height of 1/2". A change in level between 1/4" and 1/2" shall be beveled with a slope no greater than 50%. Changes in level greater than 1/2" shall be accomplished by means of a ramp.

CBC 11B-404.2.5, 302, 303

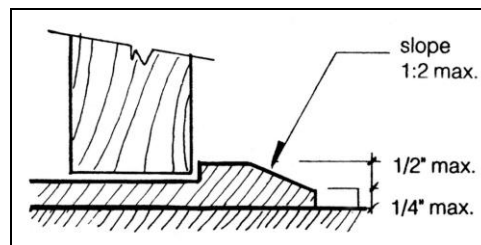

Figure 13-4 Threshold Maximum Height

VI. HARDWARE

- A. Hand-activated door opening hardware shall be 34" minimum and 44" maximum above the floor.

CBC 11B-404.2.7

Section 13 - Doors and Gates

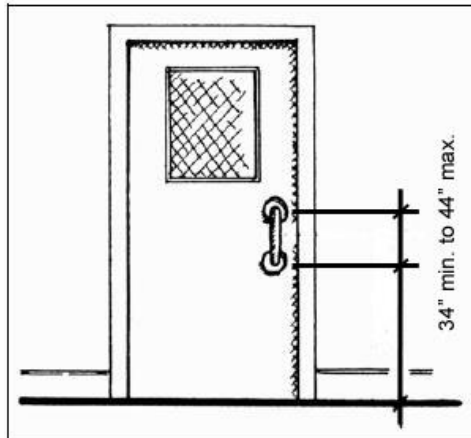

Figure 13-5 Door Opening Hardware Height

- B.** Openers must not require tight grasping, pinching or twisting to operate.
CBC 11B-309.4
- C.** When sliding doors are fully open, operating hardware must be exposed and usable from both sides.
CBC 11B-404.2.7
- D.** Interior and exterior doors must not require more than 5 lbs. of force to operate. Compensating devices or automatic door operators may be used to meet this standard.
CBC 11B-404.2.9
- E.** When fire doors are required, the maximum force to operate the door may be increased from 5 lbs. to the minimum allowable by the appropriate administrative authority not to exceed 15 lbs.
CBC 11B-404.2.9 (3)
- F.** Door closers and gate closers shall be adjusted so that from an open position of 90°, the time required to move the door to a position of 12° from the latch is 5 seconds minimum. Door and gate spring hinges shall be adjusted so that from the open position of 70°, the door or gate shall move to the closed position in 1.5 seconds minimum.
CBC 11B-404.2.8.1

Section 13 - Doors and Gates

VII. KICKPLATES

- A. The bottom 10" of all doors and gates, except automatic and sliding, shall have a smooth, uninterrupted surface to allow the doors and gates to be opened by a wheelchair footrest without creating a trap or hazardous condition.

CBC 11B-404.2.10

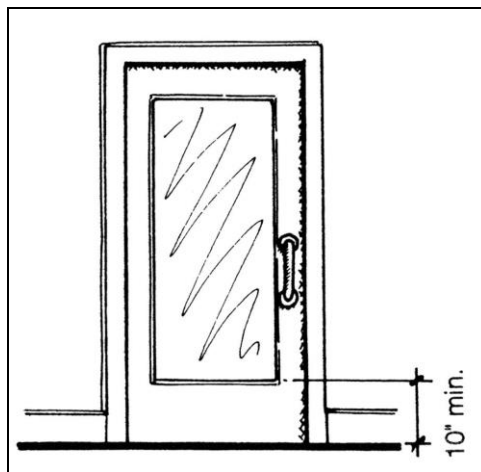

Figure 13-8 Door Kickplate

VIII. SIGNAGE

- A. When not all entrances are accessible, then those entrances that are accessible shall be identified by the International Symbol of Accessibility (ISA). Directional signs that indicate the location of the nearest accessible entrance shall be provided at non-accessible entrances. If the route to the accessible entrance diverges from the regular path of travel, directional signs with the ISA shall be placed at route junctions.

CBC 11B-216.6

★ Refer to Section 36 - Signage for design specifications.

Dormitories, Hotels & Seasonal Lodging

I. CONCEPT

- A. Cabins, yurts and similar camping structures shall follow the requirements of this section.
- B. Dormitories and similar places of seasonal lodging shall provide guest rooms per this section.
★ Refer to Section 33 - Restrooms.
- C. Guest rooms required to provide mobility features and guest rooms required to provide communication features must be dispersed among the various classes of guest rooms, and must provide choices of types of guest rooms, number of beds, and other amenities comparable to the choices provided to other guests.
1. Where the minimum number of guest rooms required is not sufficient to allow for complete dispersion, guest rooms shall be dispersed in the following priority: guest room type, number of beds, and amenities. At least one guest room required to provide mobility features must also provide communication features.
 2. Not more than 10 percent of guest rooms required to provide mobility features can be used to satisfy the minimum number of guest rooms required to provide communication features.
CBC 11B-224.5
- D. Guest rooms with mobility features must be provided in accordance with **Table 14-1**. Guest rooms with communication features must be provided in accordance with **Table 14-2**.
CBC 11B-224.2, 224.4

Section 14 - Dormitories, Hotels & Seasonal Housing

Table 14-1 Guest Rooms with Mobility Features

Total Number of Guest Rooms Provided	Minimum Number of Required Rooms Without Roll-in Showers	Minimum Number of Required Rooms With Roll-in Showers	Total Number of Required Rooms
1 to 25	0	1	1
26 to 50	1	1	2
51 to 75	3	1	4
76 to 100	4	1	5
101 to 150	5	2	7
151 to 200	6	2	8
201 to 300	7	3	10
301 to 400	8	4	12
401 to 500	9	4	13
501 to 1000	2 percent of total	1 percent of total	3 percent of total
1001 and over	20, plus 1 for each 100, or fraction thereof, over 100	10, plus 1 for each 100, or fraction thereof, over 1000	30, plus 2 for each 100, or fraction thereof, over 100

Table 14-2 Guest Rooms with Communications Features

Total Number of Guest Rooms Provided	Minimum Number of Required Guest Rooms With Communication Features
2 to 25	2
26 to 50	4
51 to 75	7
76 to 100	9
101 to 150	12
151 to 200	14
201 to 300	17
301 to 400	20
401 to 500	22
501 to 1000	5 percent of total
1001 and over	50, plus 3 for each 100 over 1000

- E. Within all lodging facilities, including cabins and yurts, **all** entrances (including routes, approaches, ramps, etc.), doors, and doorways providing user passage into and within guest rooms shall be accessible.

CBC 11B-206.5.3

★ Refer to Section 13 - Doors and Gates.

Section 14 - Dormitories, Hotels & Seasonal Housing

- F. Seasonal lodging, including units, sleeping rooms, suites and common areas, shall be on an accessible route of travel.

ADASAD 206.2.4

★ Refer to Section 7 - Buildings, and Section 34 - Routes of Travel.

- G. Parking and common use recreation facilities shall be accessible.

CBC 11B-208.1

II. SPECIFICATIONS

- A. Accessible sleeping rooms shall provide a minimum clear 36" by 48" clear space wide maneuvering space located along both sides of a bed, except where two beds are provided, provide 36" wide minimum maneuvering space between the beds.

CBC 11B-806.2.3

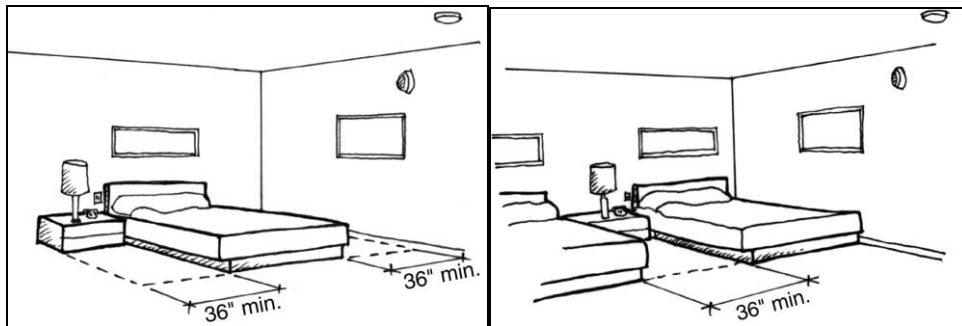

Figure 14-1 Accessible Sleeping Room

- B. In addition, there shall be a clear space under the bed for the use of a personal lift device that meets the following dimensions:

1. Clear space should be on a long side of the bed adjacent to an accessible aisle.
2. Clear space shall extend horizontally to parts not more than 12" from each end of the bed, vertically not less than 7" and not less than 30" deep.

CBC 11B-806.2.3.1

Section 14 - Dormitories, Hotels & Seasonal Housing

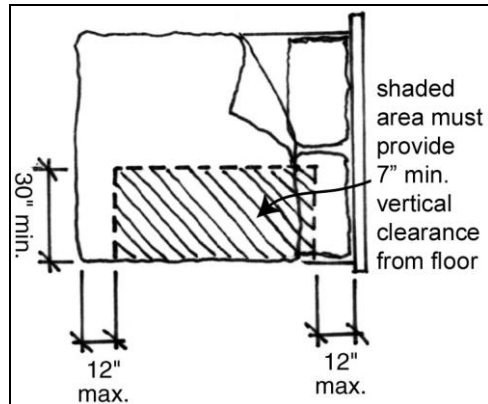

Figure 14-2 Personal Lift Device Floor Space

- C. Each additional room shall have visual fire alarms and notification devices to alert room occupants of incoming telephone calls or a knock or doorbell.
CBC 11B-806.3.1-2
- D. Doors and doorway passages must be accessible.
★ Refer to Section 13 - Doors and Gates.
- E. Bathroom doors shall not swing into the clear floor space or clearance required for any fixture. The exception being where the toilet room or bathing room is for individual use and a 30" x 48" clear floor space is provided within the room beyond the arc of the door swing, then the door may swing into the clear floor space or clearance required for any fixture.
CBC 11B-603.2.3

Dressing Rooms

I. GENERAL

- A. If permanent dressing rooms are provided at the site, regardless of location, they shall be accessible.
ADASAD 201.1
- B. Dressing rooms shall be accessible and on an accessible route of travel.
ADASAD 206.2.4
- C. The minimum number of dressing rooms made accessible shall be 5%, but never less than one, for each type of use in each cluster of dressing rooms.
ADASAD 222.1

II. ENTRY

★ Refer to Section 13 - Doors and Gates.

III. TURNING SPACE

- A. Dressing rooms shall have the prescribed minimum turning space. Doors shall not swing into the room unless the turning space is provided beyond the arc of the door swing.
CBC 11B-803.2-3
- ★ Refer to Section 0.1 - Accessibility Basics, Part IV Turning Space.

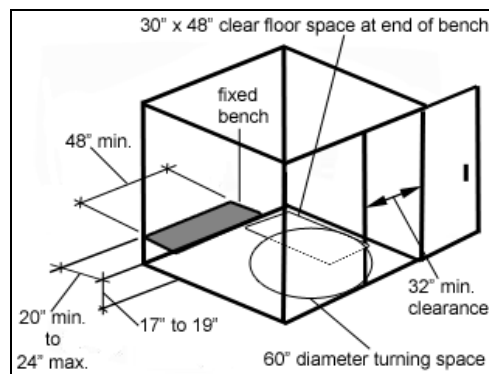

Figure 15-1 Dressing Room Clearance

Section 15 - Dressing Rooms

IV. AMENITIES

A. Every accessible dressing room shall have a fixed bench. **(Figure 15-1)**

CBC 11B-803.4, 903

1. Clear floor or ground space shall be provided and shall be positioned at the end of the bench seat and parallel to the short axis of the bench.
★ Refer to Section 0.1 - Accessibility Basics, Part V Clear Floor or Ground Space.
2. Benches shall have seats that are 48" long minimum, 20" deep minimum to 24" deep maximum and set 17" to 19" above the finished floor.
3. Benches shall be affixed to the wall or floor and shall be able to withstand 250lbs of force at any point on the bench.
4. Where installed in wet locations, the surface of the seat shall be slip resistant and shall not accumulate water.
5. The bench shall provide for back support or shall be affixed to a wall along its long dimension.
6. If a back support is provided, it shall be 48" long minimum and shall extend from a point 2" maximum above the seat surface to a point 18" minimum above the seat surface. Back support shall be 2½" maximum from the rear edge of the seat measured horizontally.

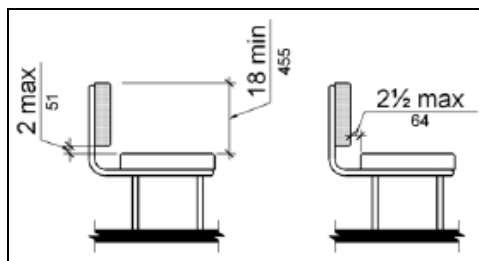

Figure 15-2 Bench Back Support

Section 15 - Dressing Rooms

- B.** Clothing hooks, when provided, shall be located no greater than 48" above the finished floor and shall not be located above the bench or other seating in the room.

CBC 11B-803.5

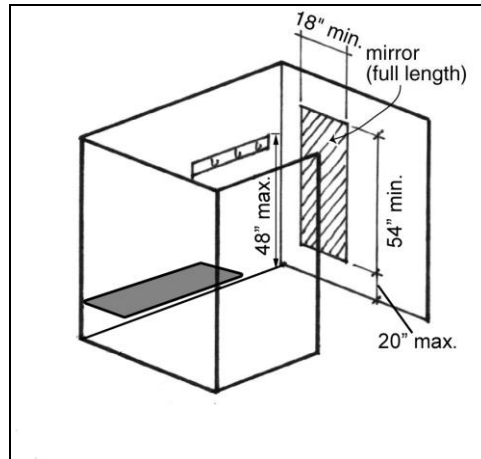

Figure 15-3 Dressing Room Clothing Hooks and Mirrors

- C.** Mirrors, when provided, shall be mounted in a position that allows a view to a person on the bench as well as to a person in a standing position. Mirrors shall measure 18" wide minimum by 54" high minimum with the bottom edge 20" maximum from the finished floor. **(Figure 15-3)**

CBC 11B-803.6

Drinking Fountains

I. CONCEPT

- A. Where drinking fountains are provided, there shall be accessible drinking fountain(s).
ADASAD 602.1
- B. The drinking fountain must be on an accessible path of travel
★ Refer to Section 34 - Routes of Travel.

II. WALL MOUNTED UNITS AND POST MOUNTED UNITS

- A. Where only one drinking fountain is provided, the use of a “Hi-Low” fountain can be used for accessibility.
ADASAD 211.2 Exception
- B. If more than one drinking fountain is provided, at least 50% must be accessible.
ADASAD 211.3
- C. The fountain shall not encroach into an accessible route.
CBC 11B-602.9
- D. There shall be a clear, level space of at least 30” x 48” in front of the fountain to allow for a forward approach.
CBC 11B-602.2

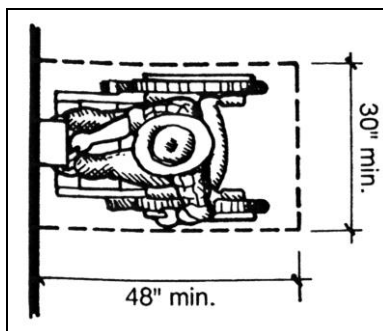

Figure 16-1 Clear Space for a Forward Approach

Section 16 - Drinking Fountains

- E. The fixture shall be a minimum 18" deep, maximum 19" deep.
CBC 11B-602.8

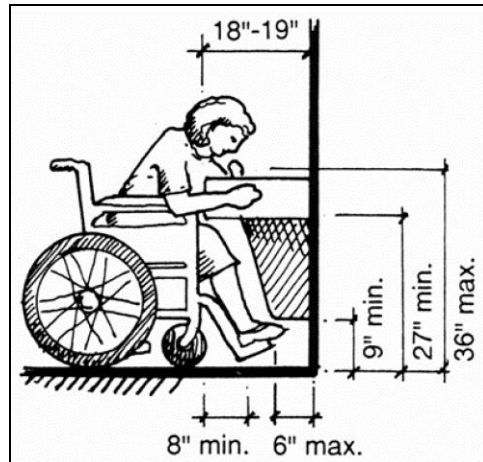

Figure 16-2 Water Fixture Clearance

- F. Clear knee space beneath the fountain shall be a minimum of 27" high, 30" wide and 8" deep, with additional minimum toe space of 9" high by 17" deep.
(Figure 16-2)
CBC 11B-602.2

G. Water Spout

1. Spout outlets shall be 36" maximum above the finish floor or ground.
CBC 11B-602.4
2. The spout shall be located 15" minimum from the vertical support and 5" maximum from the front edge of the unit, including bumpers.
CBC 11B-602.5

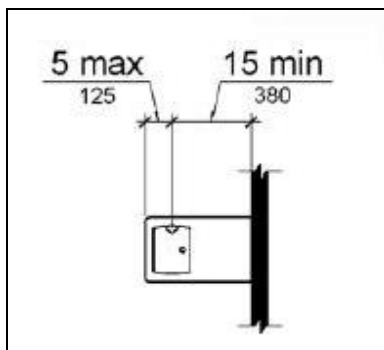

Figure 16-3 Water Spout Placement

Section 16 - Drinking Fountains

3. The spout shall provide a flow of water 4" high minimum and shall be located 5" maximum from the front of the unit. The angle of the water stream shall be measured horizontally relative to the front face of the unit. Where spouts are located less than 3" of the front of the unit, the angle of the water stream shall be 30° maximum. Where spouts are located between 3" and 5" maximum from the front of the unit, the angle of the water stream shall be 15° maximum.

CBC 11B-602.6

- H. Activation shall be by means of lever controls or a wide, non-recessed press bar located at a maximum of 6" from the front edge of the unit and requiring no more than 5 lbs. of pressure, without tight grasping, pinching or twisting.

CBC 11B-602.3

III. WALL MOUNTED UNITS

- A. Where provided, wall mounted units shall be located completely within an alcove, or with wing walls, or so as not to encroach into pedestrian ways.

CBC 11B-602.9

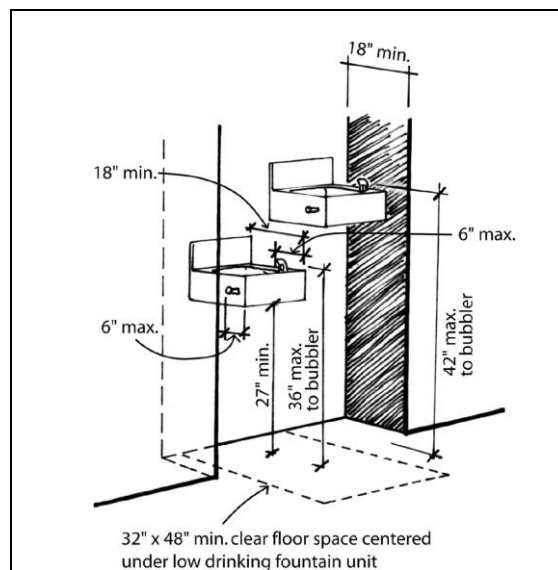

Figure 16-4 Water Fixture within an Alcove

- B. Alcove or wing wall of fountain shall be no less than 32" wide and 18" deep.

CBC 11B-602.9

Equestrian Facilities

I. CONCEPT

- A.** Equestrian activities consist of either the facility to rent and ride or equestrian use that allows the visitor to bring a horse to ride and trailer.
- B.** Access to equestrian activities involves two basic considerations:
 - 1. Access to the place where horses are available.
 - 2. Transfer capabilities onto and off of the horse that are safe and secure. Such transfer shall be accomplished by one of three methods.
 - a. Raising the level of the rider to that of the horse's stirrups – by using a mounting platform.
 - b. Lowering the level of the horse in respect to the level of the rider – such as a 2' deep ground recess for the horse.
 - c. Providing a combination of (a) and (b).

II. LOCATION

- A.** Equestrian facilities shall be located on an accessible path of travel with appropriate support facilities, such as signage, restrooms, and parking.
 - ★ Refer to Section 34 - Routes of Travel, Section 36 - Signage, Section 33 - Restrooms, and Section 26 - Parking.

III. MOUNTING PLATFORM

- A.** An accessible mounting platform should be provided to facilitate movement to and from the horse. It shall have:
 - 1. A platform height above grade 24" to 28" as measured at the place of mounting the horse.

Section 17 - Equestrian Facilities

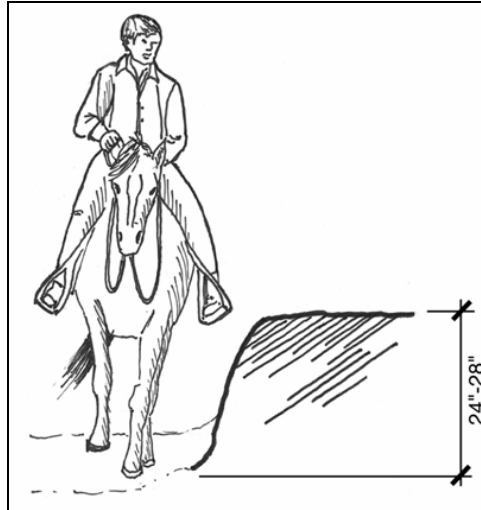

Figure 17-1 Mounting Platform Height

2. Access to the platform can be by means of a route with a maximum slope of 8.33%.
3. A 3" high curb at all edges, except for the opening on the mounting side.
4. The raised area shall be a minimum of 60" x 60" to facilitate transfer to the horse. Site selection for mounting / dismounting activities could minimize or eliminate the need for a sloped route.

☎ Contact the Accessibility Section for information on optional types of mounting facilities.

IV. AMENITIES

- A.** Amenities, such as fixed benches, lockers, hitching posts, and drinking fountains, shall be accessible.
- ★ Refer to Section 20 - Fixed Benches, Section 40 - Storage & Lockers, Section 16 - Drinking Fountains, and Section 0.1 - Accessibility Basics.

Exhibits

I. CONCEPT

- A. Exhibits are a fundamental means to inspire and educate. Making exhibits accessible requires careful planning to ensure that visitors can not only *physically* access the information provided, but that the information provided meets the varied abilities of visitors.
- B. The Accessibility Compliance Checklist for Exhibits may be found in the Appendix. This checklist contains the basic elements necessary for accessible exhibit design. Refer to this checklist when developing or redesigning exhibits to ensure that exhibits are accessible and legally compliant with all statutes and regulations.

II. EXHIBIT PLACEMENT

- A. Exhibits shall be placed along an accessible route.
 - ★ Refer to Section 7 - Buildings, Section 34 - Routes of Travel, and Section 42 - Trails.
- 1. Exhibits at non-accessible features such as a waterfall or building ruin shall have an alternate format of the exhibit available at an accessible location.
- B. Exhibits shall be placed adjacent to a clear floor or ground space for either a forward or parallel approach in accordance with Section 0.1 - Accessibility Basics, Part V Clear Floor or Ground Space.
 - 1. Clear space for exhibits placed outdoors along accessible routes should be adjacent to and outside the regular path of travel so that people who stop to examine the exhibit do not impede the passage of others.
- C. Exhibits shall be within prescribed protrusion limits in accordance with Section 0.1 - Accessibility Basics, Part VII Protruding Objects.
- D. Exhibit protective railings shall not be higher than 36" and shall not obstruct the line of vision of a person in a wheelchair.

Section 18 - Exhibits

III. EXHIBIT CONTENT

A. Layout

1. Text must be well balanced with graphics or pictures and empty space. Language used in exhibits should not be overly wordy or technical. It should be straightforward, relevant, and easy to comprehend for people of all abilities.
2. Words are easier to read in horizontal lines. Artistic word shapes must be kept to a minimum or repeated in linear format, if used.
3. Letter spacing shall be measured between the two closest points of adjacent letters, excluding word spaces. Spacing between individual letters shall be 10% minimum and 35% maximum of font height.

ADASAD 703.5.8

Table 18-1 Measuring Letter Spacing

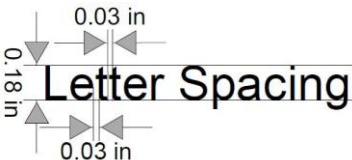
<u>Measurement</u>	<u>Result</u>	<u>Guideline</u>
	$0.03/0.18=0.16 \times 100$ Letter spacing is 16% of font height	Letter spacing shall be 10% minimum to 35% maximum of font height.

4. Spacing between the baselines of sentences within a body of text (leading) shall be 135% minimum and 170% maximum of font height.

ADASAD 703.5.9

Table 18-2 Measuring Leading

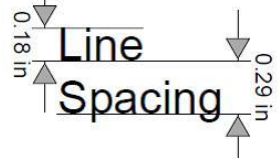
<u>Measurement</u>	<u>Result</u>	<u>Guideline</u>
	$0.29/0.18=1.61 \times 100$ Leading is 161% of font height	Leading shall be 135% minimum to 170% maximum of font height.

5. Maintaining a line length between 45 and 60 characters with margins flush left and ragged right is optimal. Where columns of text are used, space

Section 18 - Exhibits

between columns must be large enough so viewers do not read across columns.

6. Finishes shall be non-glare, eggshell or matte. Text screened directly onto clear glass or Plexiglas is very difficult to see and shall not be used.
7. Exhibit labels in cases or on shelves shall be placed at readable heights and angles for persons who are seated or standing. Avoid placing labels flat on horizontal shelf surfaces. Labels placed at 45 degree angles to front plane of case are generally easier to see.

B. Font

1. Font Family – The font family used for exhibits, panels, labels, maps, audiovisuals, and digital media shall be legible for persons with varied levels of vision.
 - a. Preferred font families include sans serif fonts. Some examples of sans serif font families include: Arial, Franklin Gothic Book, Lucida Sans, Myriad Pro, Tahoma, and Trebuchet MS.
 - b. Some examples of serif font families that work well include: Adobe Caslon Pro, Bodoni MT, Century Schoolbook, and Garamond.
 - c. The number of font families in a given exhibit should not exceed two or three.
2. Font Styles – All caps, bold, and italic are difficult to read when used for entire blocks of text. Instead, limit the use of these styles to accent or emphasize important information.
ADASAD 703.5.3
3. Font Proportions - Avoid fonts that are very heavy, very thin, or decorative and those with letters that are either very close together or widely spaced. Font proportions shall meet the following guidelines:
 - a. The width of the uppercase letter “O” shall be 60% minimum and 110% maximum of the height of the uppercase letter “I.”
CBC 11B-703.5.4
 - b. Stroke thickness of the uppercase letter “I” shall be 10% minimum and 20% maximum of the height of the character.
CBC 11B-703.5.7

Section 18 - Exhibits

Table 18-3 Font Width and Stroke Thickness

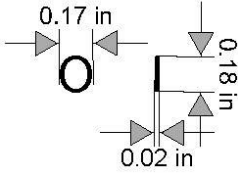
<u>Measurement</u>	<u>Result</u>	<u>Guideline</u>
	<p>width of O is 94% of height of I</p> <p>thickness of I is 11% of height of I</p>	<p>width of O is 60% minimum to 110% maximum of height of I</p> <p>thickness of I is 10% minimum to 20% maximum of height of I</p>

- Font Height – Font used in the main body of exhibit panels, reader rails, maps etc., or exhibits with an audiovisual component shall have a minimum font height based on the proposed viewing distance from the eyes to the exhibit. Map fonts that are subject to these guidelines are those that identify significant features. Refer to Section 31 - Publications for a list of significant features.

Font height shall be measured using the uppercase I according to **Table 18-4**:

Table 18-4 Minimum Font Height by Viewing Distance

Viewing Distance from eyes to exhibit	Height in Inches	Approximate Font Point
≤12"	$\frac{3}{16}$ "	18
>12" to ≤24"	$\frac{1}{4}$ "	26
>24" to ≤48"	$\frac{3}{8}$ "	37
>48" to ≤72"	$\frac{1}{2}$ "	50
>72"	$\frac{1}{2}$ ", plus $\frac{1}{8}$ " per 24" of viewing distance above 72"	50, plus 14-points per 24" of viewing distance above 72"

- Caption Font Height – Captions briefly describe images or figures, provide credits, can be used as labels to identify artifacts, or are used to identify features of lesser significance on maps.

Section 18 - Exhibits

Caption font height shall be measured using the uppercase I according to **Table 18-5:**

Table 18-5 Minimum Caption Height by Viewing Distance

Viewing Distance	Height in Inches	Approximate Font Point
≤12"	1/8"	14
>12" to ≤24"	3/16"	18
>24" to ≤48"	1/4"	26
>48" to ≤72"	3/8"	37
>72"	3/8", plus 1/8" per 24" of viewing distance above 72"	37, plus 14-points per 24" of viewing distance above 72"

C. Contrast

1. Fonts and their background shall have a non-glare finish. Fonts shall contrast with their background with either dark fonts on a light background or light fonts on a dark background.

ADASAD 703.5.1

2. Placing text over images or patterns forces readers' eyes to constantly adjust to varying contrasts and greatly reduces legibility for those with visual or learning disabilities. Use screens or place text over a solid background to achieve the recommended minimum contrast.

- a. If light reflectance values (LRV) are available, contrast percentage may be calculated using the following formula:

$$([B1-B2]/B1) \times 100 = \text{Contrast}$$

B1 = Light Reflectance Value (LRV) of the lighter color and B2 = LRV of darker value.

A minimum of 70% contrast between font and background is recommended. To determine LRV, reference the paint swatch or contact the manufacturer of the chosen paint.

Section 18 - Exhibits

- b. Contrast can be measured on digital/electronic versions of exhibit media by evaluating the relative luminance of the Red, Green, Blue (RGB) values between the font and the background. Ensure a minimum contrast ratio of 3:1 (for font that is 18-point minimum) by using the World Wide Web Consortium's (W3C) "G145" technique. Several contrast evaluation tools based on their technique are available online or for download.

Visit www.w3.org for more information or ☎ contact the Accessibility Section for assistance.

D. Color

1. When choosing colors for fonts and backgrounds, research suggests that visibility for persons with low vision will be enhanced by considering the following:
 - a. Avoid using red and green against each other as text and background, as persons with red-green color deficiencies (the most common color deficiency) are not able to easily distinguish the two.
 - b. Avoid contrasting colors from adjacent hue families in the color circle (such as orange and yellow, orange and red, yellow and green, blue and green, blue and violet) as they often lack adequate contrasts.
 - c. Even if they are from different hue families, colors of similar lightness (such as gray-blue and gray-brown) are difficult for persons with certain color deficiencies to see.
 - d. If colors from the same hue families (blue and light blue, brown and tan, etc.) are used adjacent to each other, contrast should be exaggerated to reach the recommended minimum.

E. Light Levels

1. Lighting shall be considered during exhibit design to minimize glare and so that adequate lighting is provided for the entire exhibit.
2. Provide at least 10 foot-candles of light on an exhibit. This is the minimum light level at which someone with low vision can see an object. If displaying sensitive materials that require a maximum of 5 foot-candles then:

Section 18 - Exhibits

- a. Position the items to allow the visitor to approach them as closely as possible.
 - b. Light the environment with even light; do not spotlight an object.
 - c. Provide the highest contrasting background possible.
 - d. Present the object in an alternate format, such as a reproduction, brochure, or a photograph that can be viewed in a brighter location.
3. One foot-candle is the illuminance at a point on a surface that is one foot from, and perpendicular to, a uniform point source of one candle.

1 foot-candle = 1 lumen/square ft

For comparison, a standard 60-Watt CFL outputs roughly 800 lumens and would provide the minimum light required on an exhibit in a room that is 80 square ft.

IV. REQUIREMENTS BY EXHIBIT TYPE

A. Vertical

1. Vertical exhibits include but are not limited to panels, signs, brochures, etc.
2. To allow both a seated and standing person to read vertical exhibit material, the material shall be mounted based on the optimal field of vision for sitting and standing adults.
3. The optimal field of vision for a standing adult on a vertical surface varies from 55" to 69" from the ground. The median height is 62". For seated adults in a standard wheelchair the range is 42" to 50" from the ground. The median height is 46".
4. Vertical exhibit panels with most text and graphics between the 46" and 62" medians, and with most of the core information centered on the 54" midpoint of the two medians will be within most viewers' comfortable range of vision. Actual exhibit panel size may exceed these dimensions.

Section 18 - Exhibits

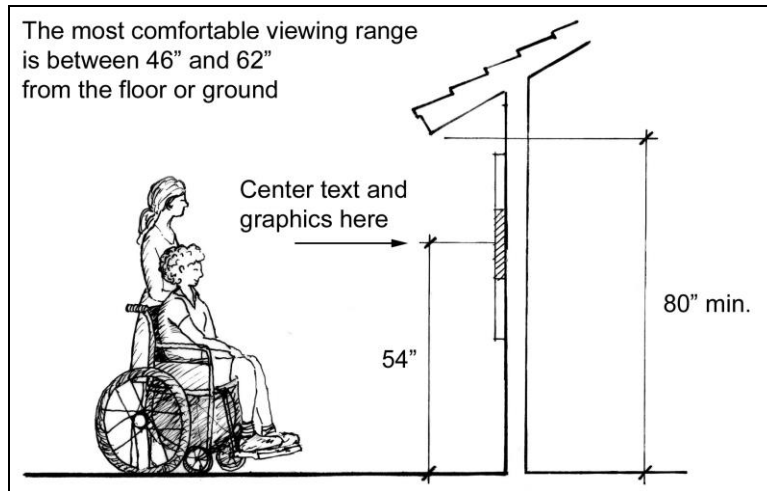

Figure 18-1 Vertical Exhibit Placement

5. Vertical exhibits that have roofs shall have a clear space of at least 80" between the lowest edge of the roof and the floor or ground. **(Figure 18-1)**
 - a. A cane detectable barrier is required within 27" from the floor or ground where the vertical clearance is less than 80".
 - ★ Refer to Section 0.1 - Accessibility Basics, Part VII Protruding Objects.

B. Angled

1. Angled exhibits include but are not limited to panels, reader rails, waysides, etc.
2. Angled exhibits shall be placed at angles from 30° to 60° from the floor or ground and 27" minimum to 34" maximum above the floor or ground.

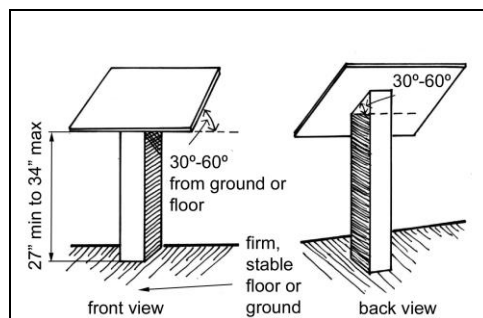

Figure 18-2 Angled Exhibit Placement

Section 18 - Exhibits

3. Angled exhibits featuring interactive components and/or controls to manipulate shall include knee and toe clearance as per the requirements for tables and counters, controls must be within reach ranges for an obstructed high forward reach, and controls shall be accessible.
★ Refer to Section 12 - Dining & Banquet Areas, Part III Knee Clearance and Section 0.1 - Accessibility Basics, Part VIII Reach Range; Part IX Operable Parts.

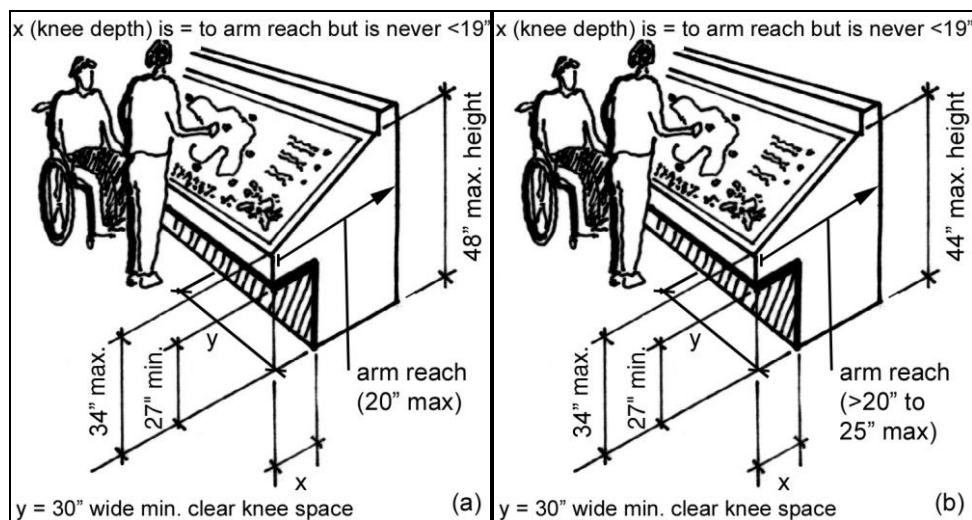

Figure 18-3 Angled Interactive Exhibit Clearance and Reach Range

C. Table-Top

1. The top of a table-top exhibit shall be 28" minimum and 34" maximum above the floor or ground.
ADASAD 902.3
2. Table-top exhibits (such as relief maps) featuring interactive components and/or controls to manipulate shall include knee and toe clearance as per the requirements for tables and counters, controls must be within reach ranges for an obstructed high side reach, and controls shall be accessible. Where it does not create a hazard for persons with low vision, 29" high knee space is recommended for wheelchair users.
★ Refer to Section 12 - Dining & Banquet Areas, Part III Knee Clearance and Section 0.1 - Accessibility Basics, Part VIII Reach Range; Part IX Operable Parts.

Section 18 - Exhibits

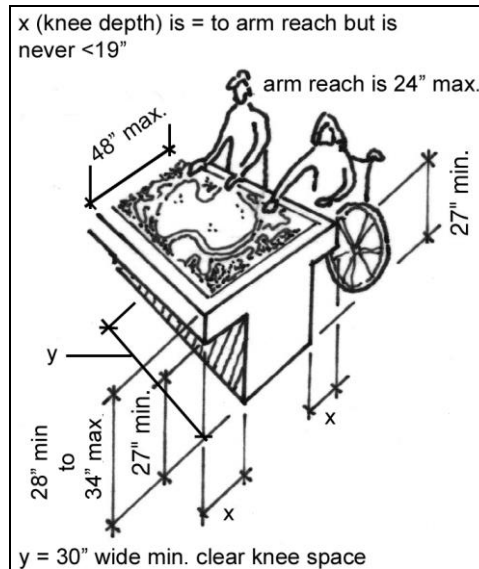

Figure 18-4 Table-Top Interactive Exhibit Clearance and Reach Range

D. Vitrines

1. Vitrines should permit up close viewing by people who are seated or standing based on a top-down or eye-level view.
 - a. Top-down view: Items meant to be looked down upon shall be mounted no higher than $32"$ from the floor. Case cover should be kept low enough to the items to permit close inspection. If an item is too large to be looked down upon, consider mounting at an eye-level view.

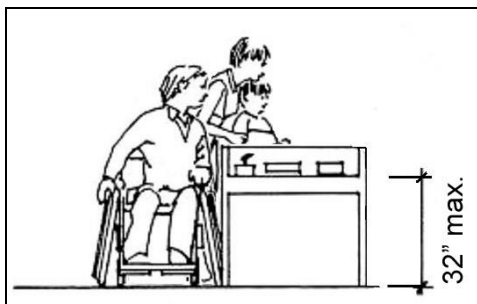

Figure 18-5 Item Mounting Height in a Vitrine, Top-Down View

Section 18 - Exhibits

- b. Eye-level view: Items meant to be viewed near eye-level, where the case is free standing or recessed into a wall, shall be mounted no higher than 42" from the floor. Case cover may be as tall as necessary.

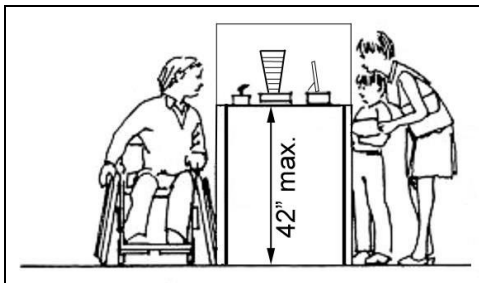

Figure 18-6 Item Mounting Height in a Vitrine, Eye-Level View

2. Consider constructing vitrines at an angle to increase access for all audiences.
☎ Contact the Accessibility Section for guidance.

E. Audiovisual

1. Exhibits with audiovisual equipment, including touchscreens, shall meet the guidelines outlined in *Section 3 - Audiovisual Programs*. Panels with text and/or graphics that may be associated with the audiovisual program shall meet the guidelines outlined in parts II and III of this section.

F. Tactile

1. In order to appeal to a variety of senses, tactile and hands-on exhibits may be better teaching tools that reach broader audiences than purely graphical exhibits and should be considered whenever possible.
 - a. Provide models, either life-size or to scale, of rare or fragile objects that may be touched. If the object is very large, a reproduction of a part of it should be available so that visitors can get an idea of its relative size.
 - b. Provide magnifiers for visitors to examine photographs, artifacts and mounted exhibit items.
2. Where exhibits are placed along accessible trails, designers should consider providing raised tactile lettering for short descriptive text such as plant names, station names, number stops, etc.

Section 18 - Exhibits

- a. Where provided, raised tactile lettering shall be uppercase, 5/8" minimum to 2" maximum in height and shall be raised 1/32" above the surface.
CBC 11B-703.2

V. ALTERNATE FORMATS

- A. Alternate formats for exhibit information shall be readily available. The type of alternate format is dependent upon the type of exhibit and the preferred format of the requestor. Every attempt should be made to provide the type of alternate format requested.
 1. The responsibility for creating alternate formats lies with the originator of the exhibit and should be considered a project deliverable when planning and designing an exhibit. Alternate formats for existing exhibits are the responsibility of the party managing exhibits in the District.
 2. Staff and volunteers should be well versed in exhibit content and prepared to provide alternate format materials. Often, a knowledgeable staff member or volunteer can provide enhanced exhibit information in alternative ways to satisfy visitors immediately upon request.
- B. Alternate exhibit formats include but are not limited to: Braille, large print format (minimum 18 point sans serif), transcripts, digital or web format, touchable objects, audio description of visual content, captioning, etc.

VI. REFERENCES

- A. "Signage and the 2010 ADA Standards v2.1". *Luminant Design LLC*, 2011. Accessed August 2014, <http://www.luminantdesign.com/ada.html>
- B. Cooper, Michael et al. "G145: Ensuring that a contrast ratio of at least 3:1 exists between text (and images of text) and background behind the text". *Techniques and Failures for Web Content Accessibility Guidelines 2.0. W3C*, 8 April 2014. Accessed August 2014, <http://www.w3.org/TR/WCAG20-TECHS/G145.html>
- C. Arditi, Aries. "Effective Color Contrast". *Lighthouse International*, 2005. Accessed August 2014, <http://www.lighthouse.org/accessibility/design/accessible-print-design/effective-color-contrast>

Section 18 - Exhibits

- D. Williams, Bill. "Footcandles and Lux for Architectural Lighting (An introduction to Illuminance)". *Bill Williams and Associates*, 1999. Accessed August 2014, <http://www.mts.net/~william5/library/illum.htm>
- E. "Smithsonian Guidelines for Accessible Exhibition Design". *Smithsonian Institution*, 2014. Accessed August 2014, <http://www.si.edu/accessibility>
- F. "Programmatic Accessibility Guidelines for National Park Service Interpretive Media". *Harpers Ferry Center, National Park Service*, February 2012. Accessed August 2014, <http://www.nps.gov/hfc/accessibility/>

Fishing

I. CONCEPT

A. Fishing is an activity that can be universally enjoyed. Every effort should be made to develop fishing opportunities that are fully accessible where fishing is a program or activity offered to the public.

ADASAD 1005

B. Fishing may take place from any of three types of locations:

1. Fixed or floating pier/dock
2. Bank or shoreline
3. Boat

C. The primary issues in the design of accessible fishing sites are:

1. Locating good fishing sites.
2. Integrating the site with an accessible path of travel and support facilities.
3. Consideration of seasonal changes in water level.
4. Safety, including safe levels of lighting.

D. Accessible fishing sites shall be fully integrated with an accessible path of travel offering appropriate support facilities.

1. Accessible fishing sites shall be appropriately identified with the International Symbol of Accessibility (ISA) at the site and at routes of travel leading to the site (e.g. parking, restrooms, etc.).

E. Fishing sites may be developed or undeveloped.

1. Developed sites are firm, level pads provided at the edges of streams, lakes or the seashore (for surf fishing).

Section 19 - Fishing

2. Undeveloped sites have not been significantly modified by construction, but are more analogous to rest areas in the pathway and trail system. They are firm, level areas at the water's edge and of sufficient dimension for wheelchair use.

II. SAFETY

- A. All reasonable precautions should be taken to ensure a safe and comfortable fishing environment appropriate to the site.
- B. Floor or grade surfaces of the site (platforms, piers, etc.) shall be made of non-slip materials.

III. FISHING PIERS AND PLATFORMS

- A. Fishing sites over water may be on fixed piers or floating docks.
- B. Access to the fishing site shall be by means of an accessible route of travel.
ADASAD 1003.2
- C. The fishing site should extend over the water for a distance that allows fishing at both high and low water conditions.
- D. Floating sites shall have enough stability and flotation to support the additional weight of people and equipment without significantly affecting the equilibrium of occupants.
- E. Piers shall have a minimum 2" high edge protection.
ADASAD 1005.3
- F. All gaps in horizontal walking surfaces shall be less than ½".
ADASAD 302.3

IV. CONNECTION TO SHORE

- A. Shore connections between the dock and land shall have a 36" minimum clear width.
- B. The surface material of the gangway or bridge shall be slip-resistant.

Section 19 - Fishing

- C. Where the total length of the gangway or series of gangways is less than 30' the slope cannot exceed 1:12. Where the total length is greater than 30' the slope may exceed 1:12.

ADASAD 1005.1(2)

- D. Gangways are not required to have landings at the end if transition plates are provided.

★ Refer to Section 6 - Boating.

- E. Handrail extensions are not required where gangways and transition plates connect and both are provided with handrails.

ADASAD 1005.1(1), 1003.2.1(6)

V. SPACE NEEDED

- A. There should be provision for a minimum of five linear feet per person along the water's edge. These dimensions intentionally exceed minimum wheelchair requirements. General spatial allowances are essential because privacy and solitude are very strong motivational factors for many anglers.

- B. Fishing site surfaces and railings shall be of non-glare materials.

- C. A minimum 30" x 48" clear space shall be provided at the accessible fishing site and the surface should be firm, stable and slip-resistant

★ Refer to Section 0.1 - Accessibility Basics.

- D. A maneuvering space of at least 60" in diameter or a T-intersection at least 36" wide must be provided to allow a person using a mobility device or wheelchair to make a 180-degree turn. The space may overlap the accessible route and clear floor or ground space.

★ Refer to Section 0.1 - Accessibility Basics.

- E. The overhead casting clearance at fishing sites should be 12'.

Section 19 - Fishing

VI. RAILINGS

A. Where provided, railings, guards, or handrails shall comply with the following:

1. At least 25 percent of the railings, guards, or handrails shall be 34 inches maximum above the ground or deck surface.

ADASAD 1005.2.1

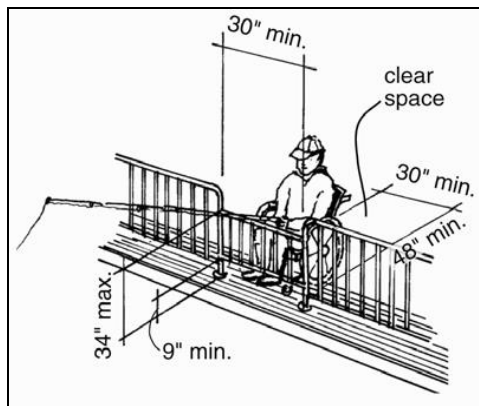

Figure 19-1 Railing Clearance

2. Railings, guards, or handrails required to comply with item (1.) above shall be dispersed throughout the fishing pier or platform.

ADASAD 1005.2.1.1

3. Where a code compliant guard (42" high; no openings permitting passage of a 4" diameter sphere, etc.) is provided, then 34" rails are not required.

CBC 11B-1005.2.1 EXCEPTION

★ Contact the Accessibility Section for assistance

B. Where railings, guardrails or handrails are provided, edge protection at a minimum of 2" high above the ground or deck surface shall be provided.

ADASAD 1005.3-1005.3.1

Section 19 - Fishing

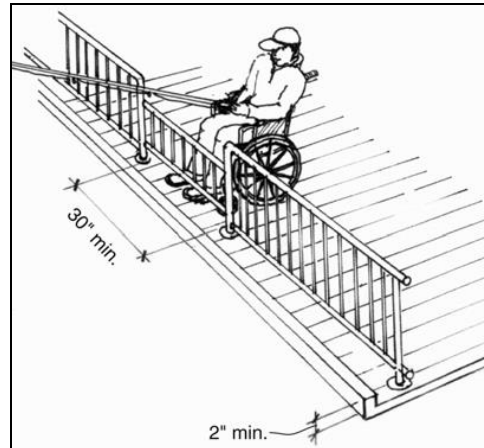

Figure 19-2 Railing Edge Protection

1. Edge protection is not required when the deck surface extends a minimum of 12" beyond the inside face of the railing, guardrail, or handrail. Toe clearance must be at least 30" wide and 9" minimum above the ground or deck surface beyond the railing
ADASAD 1005.3.2

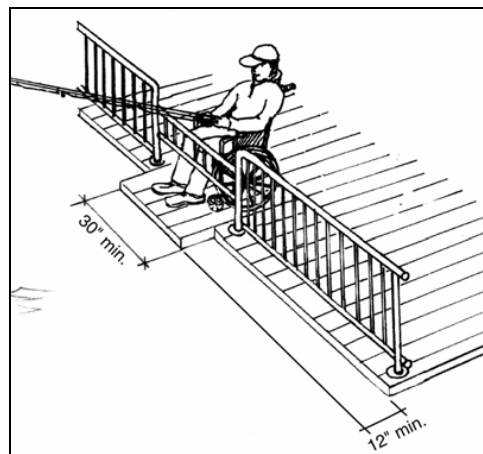

Figure 19-3 Railing Edge Protection Exception

- C.** Railings must support 250 lbs. of force in any direction.

Section 19 - Fishing

VII. CLEANING TABLES

- A. If fish cleaning tables are provided for standing persons, there shall be a proportionate section of table at 28" to 34" high, with clear knee and toe space that is at least 17" deep and 30" wide underneath available for seated persons.

ADASAD 902.2

★ Refer to Section 0.1 - Accessibility Basics, Part VI Knee and Toe Clearance.

- B. Faucet controls must be operable with a closed fist; the activation force must be 5 lbs. or less and, if self-closing, must stay on at least 10 seconds.

ADASAD 606.4

VIII. BENCHES

- A. If fixed benches are provided:

★ Refer to Section 20 - Fixed Benches.

Fixed Benches

I. CONCEPT

- A. Fixed benches, where provided, must be made accessible for users with various types of disabilities.
AGODA 1011.1
- B. At least 20%, but not less than one, of the fixed benches being provided in a facility or a building shall be accessible and shall be dispersed among the types provided.
AGODA F245.3
- C. Benches required to be accessible shall be adjacent to an accessible route of travel.
★ Refer to Section 34 - Routes of Travel.

II. CLEAR SPACES

- A. The surface around the accessible bench shall be firm and stable.
AGODA 1011.2.2
- B. A minimum area of 30" x 48" shall be provided at one end of the fixed bench so that a wheelchair user may be seated shoulder-to-shoulder with an individual seated on the bench (shoulder alignment point of the wheelchair space shall be measured 36" from the front of the wheelchair space).
99AG 16.12.4
ADASAD 903.2

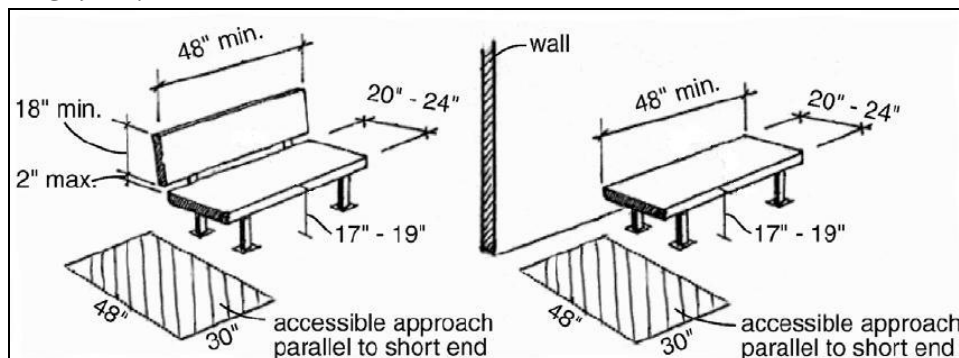

Figure 20-1 Fixed Bench Dimensions and Clear Space

Section 20 - Fixed Benches

- C. Clear spaces shall have a slope that does not exceed 2% in any direction (if necessary for proper drainage, when the surface is other than asphalt, concrete or boards, 5% maximum is allowed).

AGODA 1011.2.3

- D. The clear ground space shall not overlap exterior routes of travel, outdoor recreation access routes, trails, or another clear ground space.

AGODA 1011.2.1

III. BENCH DESIGN

- A. The fixed bench shall be free of sharp edges or protruding hardware that may be hazardous.

- B. The height of the front edge of the seating surface shall be between 17" and 19" above the adjacent grade or floor space. **(Figure 20-1)**

CBC 11B-903.5

- C. A back support shall be provided along the full length of the accessible bench. The back support shall extend from a point 2" maximum above the bench to 18" minimum above the bench. **(Figure 20-1)**

CBC 11B-903.4

- D. Accessible benches shall have seats that are 20" to 24" in depth and 48" minimum in length. **(Figure 20-1)**

CBC 11B-903.3

Guided & Self-Guided Programs and Tours

I. GENERAL

A. Where possible, guided & self-guided programs and tours shall be scheduled at locations that are accessible.

★ Refer to Section 34 - Routes of Travel and Section 42 - Trails.

1. Guided & self-guided programs and tours scheduled at inaccessible locations shall have a substantially equivalent accessible opportunity available.

B. Printed and electronic advertisements for guided & self-guided programs and tours shall include the required information as specified in Section 31 - Publications, Part III Required Information.

1. The essential eligibility criteria to participate in a program or tour shall be described in advertisement materials. Essential eligibility criteria may include, but is not limited to: ability to manage all personal mobility independently or with the assistance of a companion, ability to wear all protective equipment required by industry standards, ability to communicate effectively with tour guide and other participants, etc. ☎ Contact the Accessibility Section for assistance in crafting essential eligibility criteria.

C. Upon request, effort shall be made to obtain a Qualified Sign Language Interpreter (QSLI) or other auxiliary aid or service for people who are deaf or hard of hearing in accordance with Department Policy.

DOM 2607.5

☎ Contact the Accessibility Section for a QSLI resource list.

D. A portable assistive listening system should be provided for tours, special events and other activities where audible communication is integral to the program.

★ Refer to Section 2 - Assistive Listening Systems.

E. The content of a guided & self-guided program or tour should be available in alternate formats to accommodate the varying abilities of visitors.

Section 21 - Guided & Self-Guided Programs and Tours

1. Alternate formats include, but are not limited to, Braille, large print format (minimum 18-point sans serif), transcripts, digital or web format, touchable objects, audio description of visual content, captioning, etc.
- F. Park staff, docents, and volunteers leading a guided program or tour should be familiar with and employ the techniques for Guided Walks, Tours and Talks as outlined in *All Visitors Welcome: Accessibility in State Park Interpretive Programs and Facilities*.

II. SERVICE ANIMALS

- A. It is the policy of the Department that service animals be allowed into all areas that are open to the public, with few exceptions. Service animals are animals that are individually trained to perform tasks for persons who have qualifying disabilities under the Americans with Disabilities Act. Refer to DOM 2607.9 for more policy information.
1. Guided & self-guided programs and tours through natural or cultural areas may be posted as closed to all animals, including service animals, for the protection of the visitors or the resource, or during certain times such as breeding season.

Handrails

I. CONCEPT

- A. Handrails provided along walking surfaces, required at ramps, and required at stairs shall comply with the following guidelines.

II. GENERAL

- A. Handrails shall be provided on both sides of stairs and ramps.
CBC 11B-505.2

EXCEPTIONS: 1. In assembly areas, handrails are not required on both sides of aisle ramps where a handrail is provided at either side or within the aisle width, 2. Curb ramps do not require handrails, 3. At door landings, handrails are not required when the ramp run is less than 6" in rise or 72" in length.

- B. Handrails shall be continuous within the full length of each stair flight or ramp run. Inside handrails on switchback or dogleg stairs and ramps shall be continuous between flights or runs.
CBC 11B-505.3

EXCEPTION: In assembly areas, ramp handrails adjacent to seating or within the aisle width shall not be required to be continuous in aisle serving seating.

III. HEIGHT

- A. Top of gripping surfaces of handrails shall be 34" minimum and 38" maximum vertically above walking surfaces, stair nosings and ramp surfaces. Handrails shall be at a consistent height above walking surfaces, stair nosings, and ramp surfaces.
CBC 11B-505.4

Section 22 - Handrails

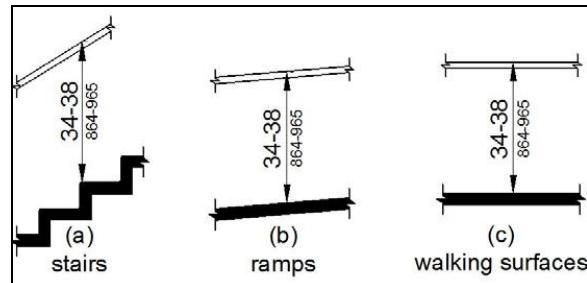

Figure 22-1 Handrail Height

IV. CLEARANCE

- A. Clearance between handrail gripping surfaces and adjacent surfaces shall be $1\frac{1}{2}$ " minimum. Handrails may be located in a recess if the recess is 3" maximum deep and 18" minimum clear above the top of the handrail.
CBC 11B-505.5

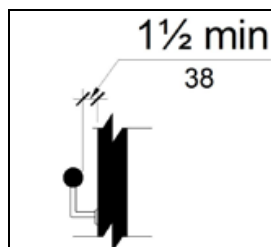

Figure 22-2 Handrail Clearance

- B. Handrail gripping surfaces shall be continuous along their length and shall not be obstructed along their tops or sides. The bottoms of handrail gripping surfaces shall not be obstructed for more than 20% of their length. Where provided, horizontal projections shall occur $1\frac{1}{2}$ " minimum below the bottom of the handrail gripping surface.
CBC 11B-505.6

EXCEPTIONS: 1. Where handrails are provided along walking surfaces with slopes not steeper than 5%, the bottoms of handrail gripping surfaces shall be permitted to be obstructed along their entire length where they are integral to crash rails or bumper guards, 2. The distance between horizontal projections and the bottom of the gripping surface shall be permitted to be reduced by $\frac{1}{8}$ " for each $\frac{1}{2}$ " of additional handrail perimeter dimension that exceeds 4"

Section 22 - Handrails

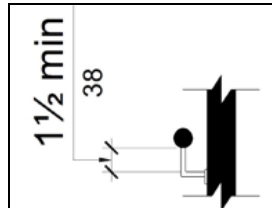

Figure 22-3 Horizontal Projections Below Gripping Surface

V. GRIPPING SURFACE

A. Handrail gripping surfaces shall have a cross section that complies with either of the following:

CBC 11B-505.7

1. Circular Cross Section: Handrail gripping surfaces with a circular cross section shall have an outside diameter of $1\frac{1}{4}$ " minimum and 2" maximum.
2. Non-circular Cross Section: Handrail gripping surfaces with a non-circular cross section shall have a perimeter dimension of 4" minimum and $6\frac{1}{4}$ " maximum, and a cross-section dimension of $2\frac{1}{4}$ " maximum.

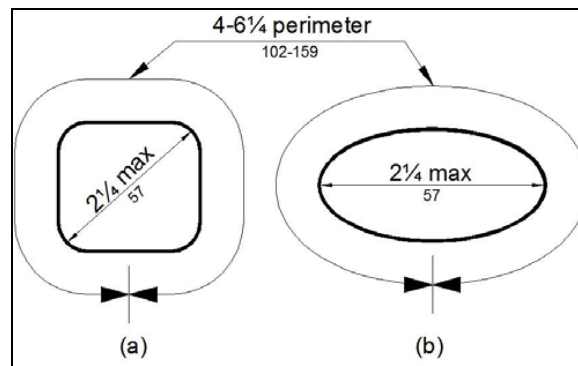

Figure 22-4 Handrail Non-Circular Cross Section

B. Handrail gripping surfaces and any surfaces adjacent to them shall be free of sharp or abrasive elements and shall have rounded edges.

CBC 11B-505.8

C. Handrails shall not rotate within their fittings.

CBC 11B-505.9

Section 22 - Handrails

VI. EXTENSIONS

- A. Handrail gripping surfaces shall extend beyond and in the same direction of stair flights and ramp runs per the following:

CBC 11B-505.10

EXCEPTIONS: 1. Extensions shall not be required for continuous handrails at the inside turn of switchback or dogleg stairs and ramps, 2. In assembly areas, extensions shall not be required for ramp handrails in aisles serving seating where the handrails are discontinuous to provide access to seating and to permit crossovers within aisles, 3. In alterations, where the extension of the handrail in the direction of ramp run would create a hazard, the extension of the handrail may be turned 90° from the ramp run.

1. Ramp handrails shall extend horizontally above the landing for 12" minimum beyond the top and bottom of ramp runs. Extensions shall return to a wall, guard, or the landing surface, or shall be continuous to the handrail of an adjacent ramp run.

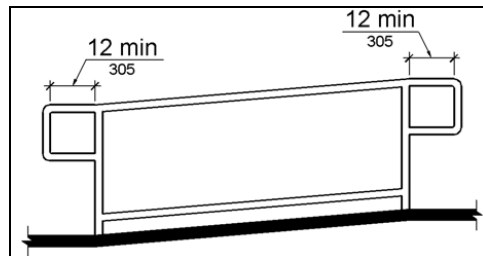

Figure 22-5 Top and Bottom Handrail Extension at Ramps

2. At the top of a stair flight, handrails shall extend horizontally above the landing for 12" minimum beginning directly above the first riser nosing. Extensions shall return to a wall, guard, or the landing surface, or shall be continuous to the handrail of an adjacent stair flight.

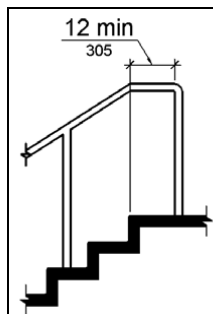

Figure 22-6 Top Handrail Extension at Stairs

Section 22 - Handrails

- At the bottom of a stair flight, handrails shall extend at the slope of the stair flight for a horizontal distance equal to one tread depth beyond the last riser nosing. Such extensions shall continue with a horizontal extension or shall be continuous to the handrail of an adjacent stair flight or shall return to a wall, guard, or the walking surface. At the bottom of a stair flight, a horizontal extension of a handrail shall be 12" long minimum and a height equal to that of the sloping portion of the handrail as measured above the stair nosings. Extensions shall return to a wall, guard, or the landing surface, or shall be continuous to the handrail of an adjacent stair flight.

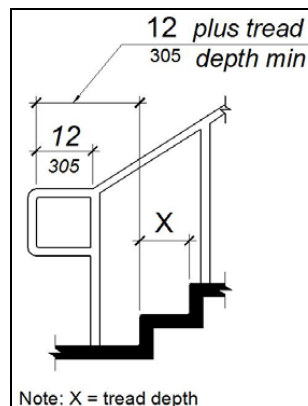

Figure 22-7 Bottom Handrail Extension at Stairs

VII. INTERMEDIATE HANDRAILS

- Where required for exiting, stairways shall have intermediate handrails located so that all portions of the stairway width required for exit capacity are within 30" of a handrail. On monumental stairs, handrails shall be located along the most direct path of exit.

CBC 10-1012.9

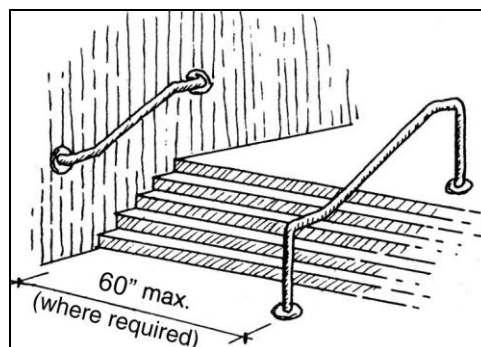

Figure 22-8 Intermediate Handrails

Historic Sites

I. CONCEPT

- A.** The Americans with Disabilities Act requires government agencies to ensure that all of their services, programs, and facilities (including historic) are accessible.
- B.** Projects involving historic buildings or properties should include input from their District Accessibility Resource Group (DARG) whenever possible. Refer to existing departmental policy on DARG requirements.
- C.** District Superintendents should verify that all proposed projects are consistent with the unit's General Plan and/or ☎ contact the General Planning Section for assistance.
- D.** Accessibility for historic buildings and properties shall be reviewed by the Accessibility Section, at the onset of the Project Evaluation Form process. All project designs must be approved and certified by the Accessibility Section.
- E.** Any departures from the highest levels of compliance shall be determined on a case-by-case basis, approved, and certified by the Accessibility Section. Reasons for departures shall be fully documented and available in public records.

II. PROCESS / APPROVALS

- A.** When performing alterations to qualified historic buildings or sites, the Regular Code for access for people with disabilities (California Building Code Chapter 11B) shall apply unless strict compliance will threaten the historical significance or character-defining features of the building or property.
CHBC 8-602.1
- B.** If the historical significance or character-defining features of the building or property are threatened, then the Alternative Provisions may be applied. Application of the Alternative Provisions shall only occur after review, and approval, by an Associate State Archeologist, State Historian II, or higher level of similar classification, or by an individual who meets the minimum

Section 23 - Historic Sites

qualifications of a professional in the disciplines of History, Archaeology, Architectural History, Architecture, or Historic Architecture as defined in the Secretary of Interior's Professional Qualifications Standards (36 CFR Part 61).

- C.** After review and approval (as noted in Part II, Letter B), application of the Alternative Provisions may be applied provided the following conditions are met:

CHBC 8-602.2

1. The Alternative Provisions shall be applied only on an item-by-item or case-by-case basis.
2. Documentation is provided, including meeting minutes or letters, stating the reasons for the application of the Alternative Provisions. Such documentation shall include detailed descriptions of the reasons why the provision of fully accessible elements would impact the historical significance or character-defining features of the building or property, and shall be retained in the official project file.

- D.** If the application of the Alternative Provisions would threaten the historical significance or character defining features of the building or property, then Equivalent Facilitation must be provided. Application of Equivalent Facilitation shall only occur after review, and approval, by the Department Preservation Officer, who has the delegated authority by the State Historic Preservation Officer (SHPO) to make final decisions on accessibility to historic buildings and properties.

CHBC 8-604

III. GUIDELINES

- A.** Regular Code (CBC 11B):

The accessibility requirements outlined in the various sections found herein (buildings, doors and gates, elevators, lifts, ramps, restrooms, routes of travel, etc.) shall be applied to qualified historic buildings or properties before applying the Alternative Provisions or Equivalent Facilitation.

CHBC 8-602.1

Section 23 - Historic Sites

B. Alternative Provisions:

If using the Regular Code would threaten the historic significance or character-defining features, the Alternative Provisions may be applied. Alternatives are to be used in priority order as listed below, with the strictest used first.

CHBC 8-602.2

1. Entry Access Route Alternatives:

CHBC 8-603.2

- a. Access to any entrance used by the general public and no further than 200' from the primary entry.
- b. Access at any entrance not used by the general public but open and unlocked with directional signs at the primary entrance and as close as possible to, but no further than 200' from, the primary entrance.

2. Door Alternatives (Regular Code requires a 32" clear opening):

CHBC 8-603.3-4

- a. A single-leaf door with at least a 30" clear opening.
- b. A single-leaf door with a 29½" clear opening.
- c. Double door, where one leaf provides a 29½" clear opening.
- d. Double doors operable with a power-assist device to provide a 29½" clear opening when both doors are in the open position. Note: Offset hinges may sometimes be used to increase clear openings by as much as 1½".
- e. Power-Assisted Doors: Power-assisted doors may be considered an Equivalent Facilitation to level landings, strikeside clearance, and door opening forces required by the Regular Code.

3. Toilet Room Alternatives:

CHBC 8-603.5

- a. In lieu of separate-gender toilet facilities as required in the Regular Code, an accessible unisex toilet facility may be designated.

Section 23 - Historic Sites

4. Exterior and Interior Ramp and Lift Alternatives:

CHBC 8-603.6

- a. A lift or ramp may have slopes up to 10% for distances up to 5'. Signs shall be posted at upper and lower levels to indicate steepness of the slope.
- b. Access may be by ramps sloped up to 16.6% for no more than 13" with signs posting slopes at upper and lower levels.

C. Equivalent Facilitation

1. Use of other designs and technologies, or deviation from particular technical and scoping requirements, are permitted if the application of the Alternative Provisions would threaten or destroy the historical significance or character-defining features of the historical building or property. Equivalent Facilitation alternatives shall only be applied upon approval of the Department's Preservation Officer and under the following circumstances:

CHBC 8-604

- a. Such alternatives shall be applied only on an item-by-item or case-by-case basis.
- b. Access provided by experiences, services, functions, materials and resources through methods including, but not limited to, maps, plans, videos, virtual reality and related equipment, at accessible levels. The alternative design and/or technology will provide substantially equivalent or greater accessibility to, and usability of, the facility.
- c. The Department Preservation Officer shall document the reasons for the application of the design and/or technologies and their effect on the historical significance or character-defining features. Such documentation shall include meeting minutes or letters, stating the reasons for the application of Equivalent Facilitation, and shall include the opinion and comments of the Accessibility Section, and the opinion and comments of representative local groups of people with disabilities. Such documentation shall be retained in the official project file and copies shall be available at the facility upon request.

Section 23 - Historic Sites

IV. DEFINITIONS

CHBC 8-201

Alteration

A modification to a qualified historical building or property that affects the usability of the building or property, or part thereof. Alterations include, but are not limited to, remodeling, renovation, rehabilitation, reconstruction, historical restoration, changes or rearrangement of the structural parts or elements, and changes or rearrangements in the plan configuration of walls and full-height partitions.

Character-Defining Feature

Those visual aspects and physical elements that comprise the appearance of a historical building or property, and that are significant to its historical, architectural and cultural values, including the overall shape of the historical building or property, its materials, craftsmanship, decorative details, interior spaces and features, as well as the various aspects of its site and environment.

Equivalent Facilitation

The use of designs, products, or technologies as alternatives to the prescribed requirements, that results in substantially equivalent or greater accessibility and usability.

Historical Fabric or Materials

Original and later-added historically significant construction materials, architectural finishes or elements in a particular pattern or configuration which form a qualified historical property, as determined by an appropriate local, state or federal governmental jurisdiction.

Historical Significance

The importance for which a property has been evaluated and designated historic by an authority with jurisdiction. This includes buildings, structures, districts or sites, generally at least 50 years old that have historical integrity, and are associated with important historic events or persons, have distinctive architectural characteristics or have potential to provide important information about pre-history or history.

36 CFR, Part 63

Section 23 - Historic Sites

Integrity

The authenticity of a building or property's historical identity, evidenced by the survival of physical characteristics that existed during the property's historical or prehistorical period. Integrity is defined by the National Register as the ability of a property to express its significance. This ability is shown by the survival of those traits and features that exemplify its significance and make the property eligible for the register. The seven aspects of integrity are: location, design, setting, materials, workmanship, feeling and association.

36 CFR, Part 60.4

Preservation

The act or process of applying measures necessary to sustain the existing form, integrity and materials of a qualified historical building or property. Work, including preliminary measures to protect and stabilize the property, generally focuses upon the ongoing maintenance and repair of historic materials and features rather than extensive replacement and new construction. New exterior additions are not within the scope of this treatment; however, the limited and sensitive upgrading of mechanical, electrical, and plumbing systems and other code-related work to make properties functional is appropriate within a preservation project.

Qualified Historical Building or Property

Any building, site, object, place, location, district or collection of structures, and their associated sites, deemed of importance to the history, architecture or culture of an area by an appropriate local, state or federal governmental jurisdiction. This shall include historical buildings or properties on, or determined to eligible for, national, state or local historical registers or inventories, such as the National Historic Register of Historic Places, California Register of Historical Resources, State Historical Landmarks, State Points of Historical Interest, and city or county registers, inventories or surveys of historical or architecturally significant sites, places or landmarks.

Reconstruction

The act or process and work of depicting, by means of new construction, the form, features, and detailing of a non-surviving site, landscape, building, property or object for the purposes of replicating its appearance at a specific period of time. The CHBC DOES NOT apply to new construction or reconstruction/replicas of historic buildings.

Section 23 - Historic Sites

Rehabilitation

The act or process of making possible a compatible use for qualified historical building or property through repair, alterations and additions while preserving those portions or features which convey its qualified historical, cultural or architectural values.

Restoration

The act or process of accurately depicting the form, features and character of a qualified building or property as it appeared at a particular period of time by the means of removal of features from other periods in its history and reconstruction of missing features from the restoration period. The limited and sensitive upgrading of mechanical, electrical and plumbing systems and other code-required work to make properties functional is appropriate within a restoration project.

V. REFERENCES

- A. For additional information, refer to Departmental Notice 2005-03, Accessibility and Historic Properties.
- B. "Archaeology and Historic Preservation: Secretary of the Interior's Standards and Guidelines [As Amended and Annotated], Professional Qualifications Standards." *National Park Service*. Accessed April 2015, http://www.nps.gov/history/local-law/arch_stnds_9.htm

Kitchens

I. CONCEPT

- A. Where kitchen facilities are provided, they must be accessible. The kitchen must be on an accessible route and all provided amenities used by the public must also be accessible to persons with disabilities.

II. COUNTERTOPS

- A. A minimum width of 30" of countertop shall be provided for the sink counter.
CBC 11B-305

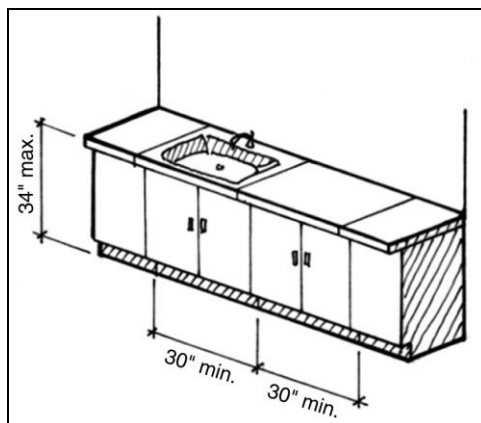

Figure 24-1 Countertop Dimensions

- B. An additional minimum width of 30" of countertop shall be provided for the adjacent workspace. **(Figure 24-1)**
CBC 11B-804.3
- C. The required accessible countertops shall be mounted no higher than 34" above the floor and shall be designed to enable repositioning to a minimum height of 28". For more information on adjustable countertops 📞 contact the Accessibility Section.
CBC 11B-902.3

Section 24 - Kitchens

- D. There shall be a 30" x 48" clear space adjacent to sinks, appliances and countertops to allow a parallel approach.

CBC 11B-606.2(1)

★ Refer to Section 0.1 - Accessibility Basics, Part V Clear Floor or Ground Space.

- E. Knee space under the sink and work counter shall be a minimum of 19" deep, 27" high and 30" wide.

CBC 11B-606.2

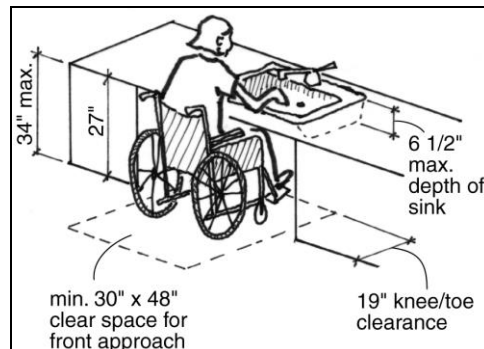

Figure 24-2 Clear Space at Sink Counter

III. CABINETS

- A. Base cabinets, including toe board and shelving, directly under the sink and work surface counters shall be removable without the use of specialized tools or knowledge.

CBC 11B-804.3.1(a)

- B. The flooring underneath removable cabinets shall be finished and extend to the wall.

CBC 11B-804.3.1(b)

- C. Walls behind and surrounding the cabinetry shall be finished.

CBC 11B-804.3.1(c)

- D. A minimum of 50% of cabinets, shelf space and refrigerator/freezer space shall be within reach ranges: 15" to 48".

CBC 11B-804.5

Section 24 - Kitchens

IV. APPLIANCES

- A. Appliances and their controls shall meet applicable Title 24 (CBC) and ADASAD regulations. ☎ Contact the Accessibility Section for questions or more information.

V. SINKS

- ★ Refer to Section 37 - Sinks.

Lifts

I. CONCEPT

- A.** Lifts can only be used in lieu of an elevator in existing buildings. In new buildings the use of a lift is limited as outlined in the following sections.
- B.** Special access wheelchair lifts may be provided between levels in lieu of an elevator when the vertical distance between landings, as well as the structural design and safeguards, are as allowed by the State of California, Division of the State Architect, Department of Industrial Relations, Division of Occupational Safety and Health and any applicable safety regulations of other administrative authorities having jurisdiction.
- C.** Platform lifts shall comply with ASME A18.1 (1999 edition or 2003 edition).
CBC 11B-410.1

II. USE OF LIFTS

- A.** Lifts shall be on an accessible route and they shall be designed and constructed to be accessible in accordance with appropriate building codes.
- B.** If lifts are provided, they shall be designed and constructed to facilitate unassisted entry, operation and exit from the lift and shall comply with the requirements of this section, in conjunction with Title 8 CCR Section 3094.
CBC 11B-410.1
- C.** Additionally, lifts may be provided as part of an accessible route only for the following conditions:
 - 1. To provide an accessible route to a performing area or stage, or to a speaking area or similar place in an assembly area.
CBC 11B-206.7.1
 - 2. To comply with the wheelchair viewing position line-of-sight and dispersion requirements.
CBC 11B-206.7.2
 - ★ Refer to Section 8 - Campfire Centers & Assembly Areas.

Section 25 - Lifts

3. To provide access to incidental occupiable spaces and rooms which are not open to the general public and which house no more than five persons, including, but not limited to, equipment control rooms and projection booths.
CBC 11B-206.7.3
 4. To provide access where existing site constraints or other constraints make use of a ramp or an elevator not feasible.
CBC 11B-206.7.5
 5. To connect levels within transient lodging guest rooms.
CBC 11B-206.7.6
 6. To be used instead of gangways that are part of accessible routes serving recreational boating facilities and fishing piers and platforms.
CBC 11B-206.7.10
- D.** The minimum landing area outside the entry and exit door to the lift shall be 60" x 60". A person using a wheelchair must be able to enter and operate the lift safely.
CBC 11B-410.7

Parking

I. CONCEPT

- A. Where parking is provided, appropriate accessible spaces shall be provided. This will include the proper number, including van spaces, with appropriate signage and location of spaces with an accessible route of travel to the facilities or activities.

II. LOCATION

- A. Accessible spaces must be located as near as possible to a primary entrance or on the shortest accessible route from parking to the facility, activity, etc.
CBC 11B-208.3.1
- B. Accessible parking spaces shall be located so visitors do not have to travel behind parked cars other than their own.
CBC 11B-502.7.1
- C. Accessible routes shall be provided from parking spaces to related facilities, including curb cuts or ramps, as needed. Ramps shall not encroach on any parking or access aisle spaces.
CBC 11B-502.3

III. SPACES REQUIRED

- A. Minimum number of accessible spaces required shall comply with **Table 26-1**.
CBC 11B-208.2

Section 26 - Parking

Table 26-1 Parking Spaces

Total Spaces Provided	Total Accessible Spaces (including van accessible)	Van Accessible Spaces
1 – 25	1	1
26 – 50	2	1
51 – 75	3	1
76 – 100	4	1
101 – 150	5	1
151 – 200	6	1
201 – 300	7	2
301 – 400	8	2
401 – 500	9	2
501 – 1,000	2% of Total	3
1,001+	20, plus 1 for each 100 over 1,000	3, plus 1 for every 6 accessible spaces

B. A minimum of one in every six accessible spaces, but no less than one, should be served by a minimum 8' wide access aisle on the passenger side and be designated with a sign as "Van Accessible."

CBC 11B-208.2.4

C. Additional standard accessible stalls may be served by a 5' wide access aisle.

IV. TIRE STOPS

A. A bumper or curb shall be provided to serve as a tire stop to prevent encroachment of cars on the required width of walkways.

CBC 11B-502.7.2

V. SURFACE

A. Accessible parking spaces are paved. For non-paved parking, ☎ contact the Accessibility Section.

Section 26 - Parking

VI. SLOPE

- A. Surface slopes of accessible parking spaces shall be kept to a minimum for surface water drainage and shall not exceed 2% in any direction.
CBC 11B-502.4

VII. SIZE

- A. Each car and van accessible parking space must be 18' minimum in length.
CBC 11B-502.2
- B. Where only one accessible space is provided (minimum required) it shall be a van accessible space. The parking space shall be 9' wide minimum and shall be adjacent to an 8' wide minimum access aisle, located on the passenger side of the vehicle. Total area width shall be 17' minimum.
CBC 11B-502.2 Exception

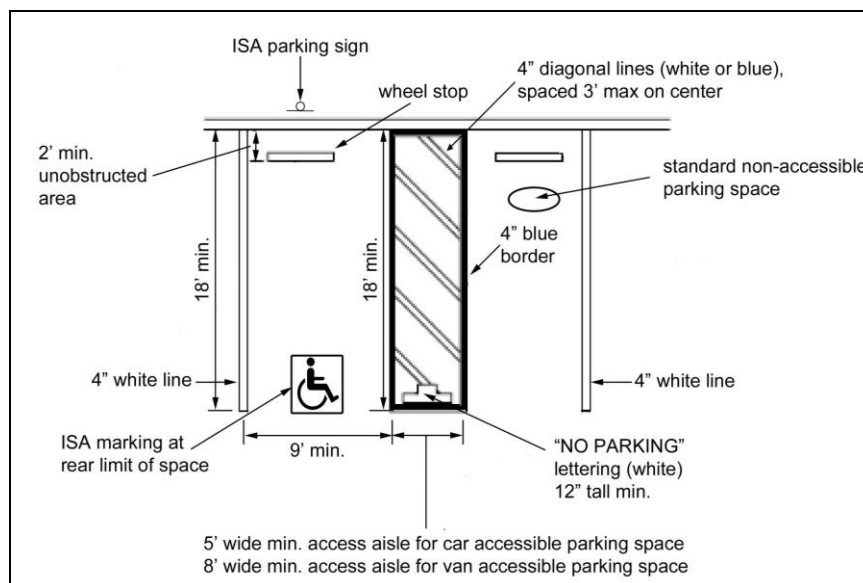

Figure 26-1 Single Perpendicular Parking Space

- C. Two accessible parking spaces shall be permitted to share a common access aisle, except for van parking spaces which shall have access aisles located on the passenger side of the parking space.
CBC 11B-502.3, 502.4

Section 26 - Parking

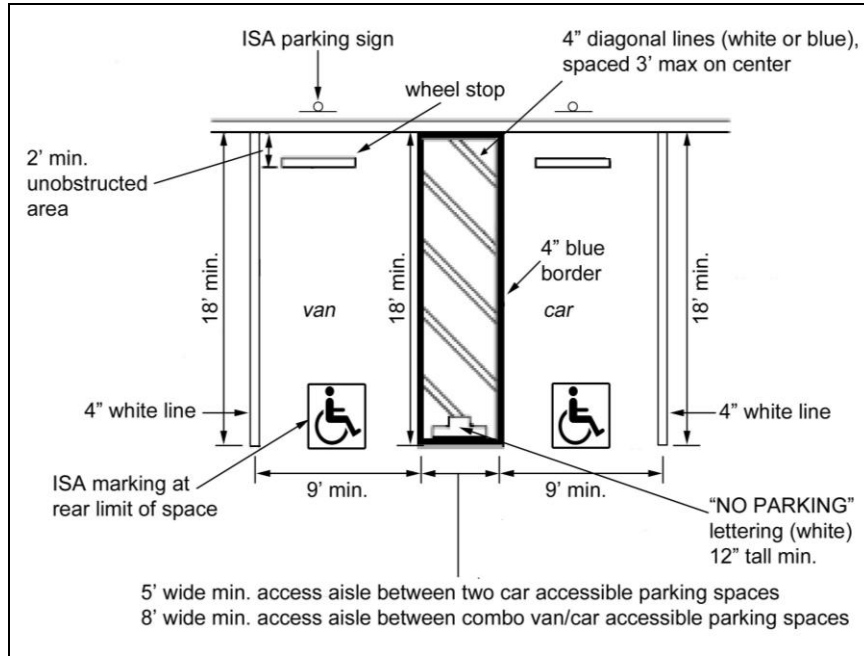

Figure 26-2 Double Perpendicular Parking Space

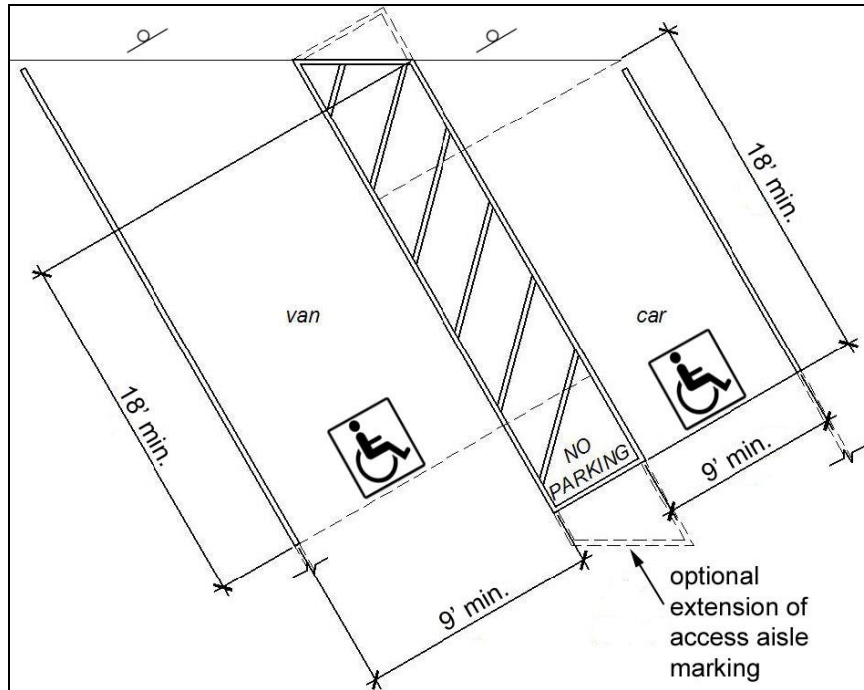

Figure 26-3 Double Angled Parking Space

Section 26 - Parking

VIII. IDENTIFICATION

- A. The surface of each accessible paved parking space shall have a surface identification, duplicating the International Symbol of Accessibility (ISA), in blue paint at least 36" square in an area located so it can be seen by a parking enforcement official. **(Figure 26-1, 26-2, 26-3)**

CBC 11B-502.6.4

- B. The aisle adjacent to a parking stall or space designated for a disabled person shall be marked by a border and hatched lines. The border shall be painted blue and the hatched lines shall be painted a suitable contrasting color to the parking space. Blue or white paint is preferred. In addition, the words "NO PARKING" shall be painted on the ground within each 5' or 8' wide aisle. This notice shall be painted in white letters no less than 12" high and located so that it is visible to traffic enforcement officials. **(Figure 26-1, 26-2, 26-3)**

CBC 11B-502.3.3

- C. A permanently affixed reflectorized sign displaying the International Symbol of Accessibility (ISA) in white on a blue background shall identify each designated space.

CBC 11B-502.6

1. The sign shall be no smaller than 70" square in area.



Figure 26-4 Accessible Parking Sign

Section 26 - Parking

- The sign shall be 60" minimum above the floor or ground measured to the bottom of the sign.
- Signs located within an accessible route shall be a minimum of 80" above the floor or ground measured to the bottom of the sign.

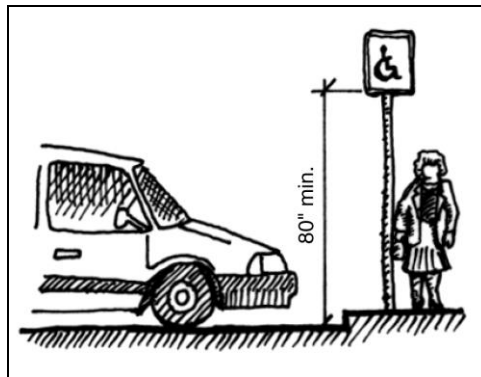

Figure 26-5 Sign Clearance

- An additional sign or additional language below the symbol of accessibility shall clearly and conspicuously state "MINIMUM FINE \$250".



Figure 26-6 Minimum Fine Sign

Section 26 - Parking

D. An additional tow-away sign, with phone number, shall be posted at each entrance to the parking facility per the following guidelines:
CBC 11B-502.8

1. The tow-away sign shall measure no less than 17" x 22", with 1" minimum lettering in black on a white background.
2. The sign shall read:

“UNAUTHORIZED VEHICLES PARKED IN DESIGNATED ACCESSIBLE SPACES
NOT DISPLAYING DISTINGUISHING PLACARDS OR
SPECIAL LICENSE PLATES
ISSUED FOR PERSONS WITH DISABILITIES
WILL BE TOWED AWAY AT THE OWNER’S EXPENSE.

TOWED VEHICLES MAY BE RECLAIMED AT:
[insert address]

OR BY TELEPHONING
[insert telephone number]”

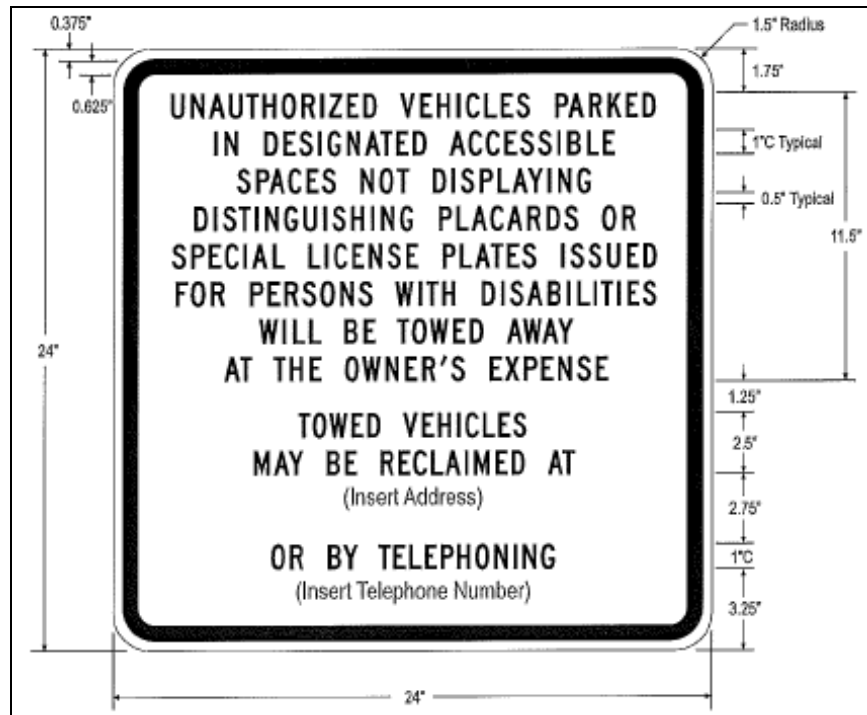

Figure 26-7 Tow-Away Sign

Section 26 - Parking

- E. Van accessible spaces shall be identified with a physically separate “VAN ACCESSIBLE” sign located below the symbol of accessibility.
CBC 11B-502.6

IX. PARKING STRUCTURES

- A. Parking structures shall have a minimum vertical clearance of 8’2” at entrances and where required for access to accessible parking spaces.
CBC 11B-502.5

X. PULL-THROUGH PARKING

- A. If pull-through parking for motorhomes, camping trailers or boat trailers is provided, it should meet the following guidelines:
1. Width of parking area should be 10’ and, if paved, the International Symbol of Accessibility (ISA) shall be painted at each end.
 2. An adjacent loading/unloading area (on the passenger side if a single parking spot) shall be 8’ wide, blue striped if paved, with a post-mounted accessibility sign on the outside edge of the loading/unloading area.

XI. PASSENGER DROP-OFF AND LOADING ZONES

- A. If passenger drop-off and loading zones are provided, one zone shall have the following:
CBC 11B-503

1. An accessible aisle 5’ x 20’ provided adjacent and parallel to the vehicle pull-up space.
CBC 11B-503.3.1-2

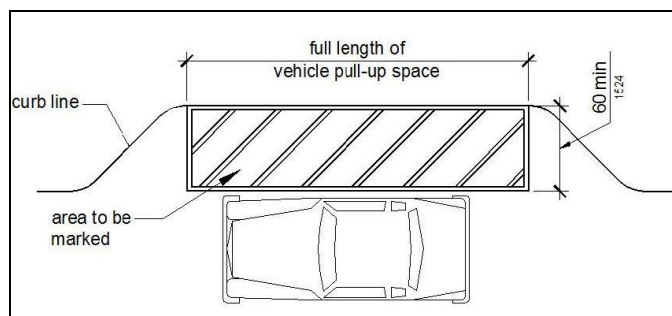

Figure 26-8 Accessible Aisle at Drop-Off or Loading Zones

Section 26 - Parking

2. Surface slope less than 2% in all directions including vehicle space.
CBC 11B-503.4 Exception
 3. Stable, firm and slip resistant surfaces.
 4. Identified by the International Symbol of Accessibility (ISA).
CBC 11B-503.6
- B.** Vertical clearance of 9'6" shall be located at the loading zone, site entrance and exit.
CBC 11B-503.5
- C.** Walk surfaces crossing or joining the vehicular way not separated by curbs, railings or other elements shall be identified with continuous, detectable warnings. These warnings shall meet the following guidelines:
1. The warnings shall be between 24" and 36" wide.
 2. They shall contrast visually with adjoining surfaces with either dark on light or light on dark.
- D.** Access aisles shall adjoin an accessible route and shall not overlap the vehicular way.
CBC 11B-503.3

XII. ELECTRIC VEHICLE CHARGING STATIONS

- A.** Per the OPR & DSA's draft "Plug-In Electric Vehicles: Universal Charging Access Guidelines and Best Practices" dated April 2013, where provided, electric vehicle charging stations shall comply with EVG-250.
1. Electric vehicle charging stations complying EVG-250 shall be provided in accordance with **Table 26-2**.
EVG-250.2

Section 26 - Parking

Table 26-2 Number of Electric Vehicle Charging Stations

Total Number of Electric Vehicle Charging Stations Provided at a Site	Minimum Number of Required Accessible Electric Vehicle Charging Stations
1-25	1
26-50	2
51- 75	3
76- 100	4
101 and over	4, plus 2 for each 100, or fraction thereof, over 100

2. Electric vehicle charging stations on public and private sites shall be dispersed within each separate type of parking facility providing electric vehicle charging to the maximum extent feasible.

EVG-250.5.1

3. Electric vehicle charging stations that serve a particular building, facility or site shall be located on an accessible route

EVG-250.5.1.2

- B.** The vehicle space designated for electric vehicle charging stations shall be 18' long minimum and 9' wide minimum and shall have an adjacent access aisle.

EVG-812.2

1. Access aisles shall adjoin an accessible route. Two electric vehicles charging stations or one electric vehicle charging station and one accessible parking space shall be permitted to share a common access aisle.

EVG-812.3

- a. The adjacent access aisle shall be 60" wide minimum.

EVG-812.3.1

- b. Access aisles shall extend the full required length of the vehicle spaces they serve.

EVG-812.3.2

Section 26 - Parking

- c. Access aisles shall be marked with a painted borderline around their perimeter. The area within the borderlines shall be marked with hatched lines a maximum of 36" on center. The color of the borderlines, hatched lines, and letters shall contrast with that of the surface of the access aisle, with white being the preferred color. The blue color required for the identification of access aisles for accessible parking **shall not** be used.
EVG-812.3.3
 - d. The words "NO PARKING" shall be painted on the surface within each access aisle in letters a minimum of 12" in height and located to be visible from the adjacent vehicular way.
EVG-812.3.4
 - e. Access aisles at on-site electric vehicle charging station spaces shall not overlap the vehicular way and may be placed on either side of the vehicle space they serve.
EVG-812.3.5
- 2. The words "ELECTRIC VEHICLE CHARGING ONLY" or "EV CHARGING ONLY" may be painted on the surface within each charging space letters a minimum of 12" in height and located to be visible from the adjacent vehicular way.
EVG-812.2.2
 - 3. Electric vehicle charging station spaces and access aisles serving them shall comply with *CBC 11B-302*.
EVG-812.4
 - ★ Refer to Section 0.1 - Accessibility Basics, Part II Floor and Ground Surfaces.
 - 4. Charging station spaces, access aisles and vehicular routes serving them shall provide a vertical clearance of 98" minimum.
EVG-812.5
- C. Electric vehicle charging stations shall be identified with signage but shall not be identified as or provided with signage required for accessible parking spaces.
EVG-812.6

Section 26 - Parking

1. Provide a sign containing language stating “Designed for Disabled Access - Use Last” in addition to the signage identifying standard electrical vehicle charging stations. Where only one electric vehicle charging station is provided the sign shall contain language stating “Designed for Disabled Access”.
EVG-812.6.1
 2. Signs shall be 60” minimum above the finish floor or ground surface measured to the bottom of the sign and shall be the uppermost sign when co-located with “No Parking except for Electric Vehicle Charging” and “Parking Time Limit” word message signs or electric vehicle charging symbol signs.
EVG-812.6.2
 3. Signs shall be reflectorized with a minimum area of 70 square inches.
EVG-812.6.3
 4. Signs shall be permanently posted immediately adjacent to and visible from each space, and shall be located within the projected width of the vehicle space. EVG-812.6.5
- D. Electric vehicle charging station vehicle spaces and access aisles shall be designed so that when occupied the required clear width of adjacent accessible routes is not obstructed.**
EVG-812.7
1. Electric vehicle charging stations and access aisles shall be designed so that persons using them are not required to travel behind electric vehicle charging stations other than to pass behind the vehicle space in which their vehicle has been left to charge.
EVG-812.7.1
 2. A curb, wheel stop, bollards or other device shall be provided if required to prevent encroachment of vehicles over the required clear width of adjacent accessible routes.
EVG-812.7.2
- E. Electric Vehicle Charging Station Equipment**
1. Equipment pedestals and pay stations that serve electric vehicle charging stations shall comply with EVG-814.1:

Section 26 - Parking

- a. At parallel electric vehicle charging station spaces, equipment pedestals and pay stations shall be on the immediately adjacent sidewalk or ground surface and located 36" maximum from the head end or foot end of the projected length of the space.
EVG-814.1.1.1
- b. At perpendicular or angled Electric Vehicle Charging Station spaces, equipment pedestals and pay stations shall be located on the immediately adjacent sidewalk or ground surface at the head end within the projected width of the electric vehicle charging station space.
EVG-814.1.1.2
2. Operable parts and charging cord stowage locations shall comply with *CBC 11B-309*.
EVG-814.1.2
★ Refer to *Section 0.1 - Accessibility Basics, Part IX Operable Parts*.
3. Displays and information shall be visible from a point located 3.3' maximum above the center of the clear floor or ground space in front of the equipment pedestal and pay station.
EVG-814.2
4. Clear floor space at electric vehicle charging stations shall comply with *CBC 11B-305* and shall be centered on the display and information side of the electric vehicle charging station equipment.
EVG-814.3
★ Refer to *Section 0.1 - Accessibility Basics, Part V Clear Floor or Ground Space*.
5. Pay stations, where provided at electric vehicle charging stations, shall comply with *Section 35 - Service Machine*.

Picnic Sites

I. CONCEPT

- A.** A picnic facility exists wherever one or more picnic tables are located. In general, picnic areas must include accessible parking, restroom, picnic units and routes that connect each of the elements throughout the area. However, for the convenience of all users, Department policy dictates that when replacing picnic site furnishings such as tables, drinking fountains and barbeques, these furnishings shall be of an accessible design.

II. SITE PLANNING

- A.** Where only two picnic units are provided in a picnic facility, they must be accessible and must be connected to an outdoor recreation access route.
AGODA F245.2.1
- B.** If there are two or more picnic tables, at least 20%, but never less than two, shall be accessible tables.
AGODA F245.2.2
- C.** Accessible picnic units shall be on an accessible route of travel.
AGODA F245.4
★ Refer to Section 34 - Routes of Travel.
- D.** Accessible picnic units shall be dispersed throughout the picnic area.
AGODA F245.2.4
- E.** The accessible picnic sites shall be located on a surface area with no greater than a 2% slope (5% slope when necessary for drainage and the surface is other than asphalt, concrete, or boards).
AGODA 1011.2.3

Section 27 - Picnic Sites

III. PICNIC TABLES

★ Refer to Section 9 - *Camping, Part V Picnic Tables.*

IV. GRILLS, FIRE RINGS AND COOKING SURFACES

★ Refer to Section 9 - *Camping, Part VI Grills, Fire Ring and Fireplaces.*

V. WATER FAUCETS

★ Refer to Section 9 - *Camping, Part VII Water Faucets.*

VI. TRASH AND RECYCLING RECEPTACLES

★ Refer to Section 9 - *Camping, Part VIII Trash Receptacles and Food Lockers.*

Play Areas

I. CONCEPT

- A.** A park location that has any number of play components designed and constructed for play, socialization, or learning by children is considered a play area. In play areas it is important that accessible equipment be integrated with non-accessible equipment. While not every piece of play equipment needs to be accessible, when non-accessible components stand alongside accessible ones, it promotes social interaction between children.
- B.** Play components can be either elevated or ground level, made of manufactured or natural materials, and may be “stand alone” or part of a composite play structure.
1. Ground level play components are those that are approached and exited at ground level (i.e., spring rockers, swings, diggers, free-standing slides, and climbers).
ADASAD 240.2.1 Advisory
 2. Play components that are attached to a composite play structure which provide more than one play activity, and can be approached above or below grade from a platform or deck are considered elevated play components.
ADASAD 240.2.2 Advisory
 3. Soft, contained play structures are made up of one or more components where the user enters a fully enclosed play environment that utilizes pliable materials such as plastic, netting or fabric.
- C.** Accessible surfaces and routes inside play areas have different criteria than accessible surfaces and routes elsewhere. Certain surfaces must meet stringent safety standards put forth by the American Society for Testing and Materials. To ensure compliance with all codes and standards it is important that park leaders and project managers  contact the Accessibility Section for guidance whenever work on a new or existing play area is planned.

Section 28 - Play Areas

II. GENERAL

- A. All newly constructed play areas designed for children ages two and over or altered portions of existing play areas shall be accessible.
ADASAD 202.1, 240.1
1. Where play components are relocated in existing play areas for the purpose of creating safe use zones or where play components are altered and the ground surface is not altered, the ground surface inside the play area shall not be required to be modified for accessibility.
ADASAD 240.1 Exception 2
- B. Where ground level play components are provided, at least one of each type shall be on an accessible route.
ADASAD 240.2.1.1
- C. Where elevated play components are provided, at least 50% shall be on an accessible route.
ADASAD 240.2.2
- D. Accessible routes serving play areas shall comply with Section 34 - Routes of Travel, Part II Exterior Routes of Travel and Parts III – VIII of this section.
ADASAD 1008.2
- E. Depending on the total number of play components provided, additional requirements may be necessary.
★ Refer to Part VIII of this Section for additional route requirements.

III. ACCESSIBLE ROUTES IN PLAY AREAS

- A. Accessible route surfaces inside play areas must comply with the American Society for Testing and Materials (ASTM) “F 1951 Standard Specifications for Determination of Accessible Surface Systems Under and Around Playground Equipment.”
ADASAD 1008.2.6.1
- B. The use zone is the ground level area beneath and immediately adjacent to a play structure or play equipment. This is the surface upon which it is predicted

Section 28 - Play Areas

a user would land when falling from or exiting the equipment and these surfaces are required to comply with the ASTM “F 1292 Standard Specifications for Impact Attenuation of Surface Systems Under and Around Playground Equipment.”

ADASAD 1008.2.6.2

C. Ground Level Accessible Routes

1. Accessible routes serving ground level play components shall have a vertical clearance of 80” high minimum.

ADASAD 1008.2

2. The clear width of the ground level accessible route shall be 60” minimum with the following exceptions:

- a. In play areas less than 1,000 square feet, the clear width may be reduced to 44” minimum, if at least one turning space that is a 60” diameter circle or T-shape, is provided every 30’.

ADASAD 1008.2.4.1 Exception 1

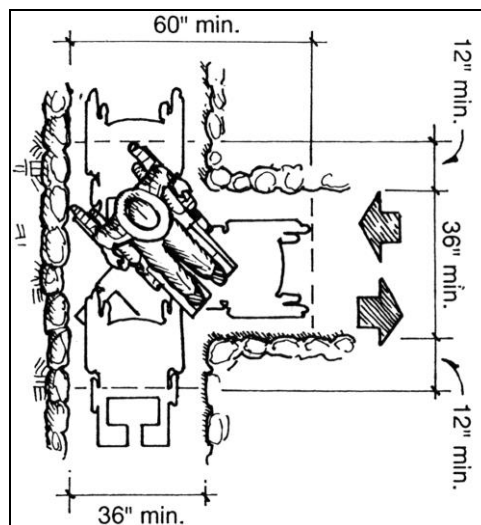

Figure 28-1 Accessible Turning Space in Play Area Routes

- b. The clear width of accessible routes may be reduced to 36” minimum for a distance of 60” maximum provided that multiple reduced width segments are separated by segments that are 60” wide minimum for at least 60” in length minimum.

ADASAD 1008.2.4.1 Exception 2

Section 28 - Play Areas

D. Elevated Accessible Routes

1. Where transfer systems are provided, an elevated play component shall be permitted to connect to another elevated play component as part of an accessible route. However, where 20 or more elevated play components are provided, no more than 25% of the elevated components are permitted to be connected by transfer systems.

ADASAD 1008.2.1 Exception 1 & 2

2. Platform lifts in compliance with all other applicable state and local codes shall be permitted to be used as part of an accessible route.

ADASAD 402.2

3. The clear width of an accessible route connecting elevated play components shall be 36" minimum with the following exceptions:

- a. The clear width of accessible routes connecting elevated play components may be reduced to 32" minimum for a distance of 24" maximum, provided that reduced width segments are separated by segments that are 48" long minimum and 36" wide minimum.

ADASAD 1008.2.4.2 Exception 1

- b. The clear width of transfer systems connecting elevated play components shall be permitted to be 24" minimum.

ADASAD 1008.2.4.2 Exception 2

IV. RAMPS IN PLAY AREAS

- A. Within play areas, ramps connecting ground level play components shall comply with the following:

1. The maximum slope on ramps connecting ground level play components shall be 6.25%.

ADASAD 1008.2.5.1

2. The maximum rise for any ramp run shall not exceed 12".

ADASAD 1008.2.5.2

Section 28 - Play Areas

3. Where required on ramps serving play components, the handrails shall comply with Section 32 - Ramps, Part V Handrails except where modified in Part V of this section.

V. HANDRAILS IN PLAY AREAS

- A. Handrails shall comply with Section 32 - Ramps, Part V Handrails except as follows:

1. Handrails are not required on ramps located within ground level use zones.
ADASAD 1008.2.5.3 Exception 1
2. Handrail extensions are not required in play areas.
ADASAD 1008.2.5.3 Exception 2
3. Handrail gripping surfaces with a circular cross section shall have an outside diameter of 0.95" minimum and 1.55" maximum. Where the shape of the gripping surface is non-circular, the handrail shall provide an equivalent gripping surface
ADASAD 1008.2.5.3.1
4. The top of the handrail gripping surface shall be 20" minimum to 28" maximum above the ramp surface.
ADASAD 1008.2.5.3.2

VI. TRANSFER PLATFORMS IN PLAY AREAS

- A. Where transfer is intended to be from a wheelchair or other mobility device, transfer platforms shall be provided.
ADASAD 1008.3.1
- B. Transfer platforms shall have level surfaces 14" deep minimum and 24" wide minimum. Height of transfer platforms shall be 11" minimum and 18" maximum above the ground or floor surface.
ADASAD 1008.3.1.1-2
- C. A clear and level 30" by 48" transfer space shall be provided adjacent to the transfer platform. The 48" long dimension of the transfer space shall be

Section 28 - Play Areas

centered on and parallel to the 24" long side of the transfer platform. The side of the transfer platform serving the transfer space shall be unobstructed.

ADASAD 1008.3.1.3

- D. A means of support such as handrails, handgrips or custom designed handholds shall be provided at each level where transferring is the intended method of access.

ADASAD 1008.3.1.4

VII. TRANSFER STEPS

- A. Transfer steps shall be provided where movement is intended from a transfer platform to a level with elevated play components that is required to be on an accessible route.

ADASAD 1008.3.2

- B. Transfer steps shall have level surfaces, 14" deep minimum, 24" wide minimum and each step shall have a maximum height of 8".

ADASAD 1008.3.2.1-2

- C. A means of support such as a loop type handle, poles, bars or custom designed handholds shall be provided at each step where transferring is the intended method of access.

ADASAD 1008.3.2.3

VIII. PLAY COMPONENTS

- A. Where elevated play components are provided, ground level play components shall be provided in accordance with **Table 28-1**.

ADASAD 240.2.1.2

Section 28 - Play Areas

Table 28-1 Number and Types of Ground Level Play Components Required to be on Accessible Routes

Number of Elevated Play Components Provided	Minimum Number of Ground Level Play Components Required To be on Accessible Route	Minimum Number of Different Types of Ground Level Play Components Required To be On Accessible Route
1	N/A	N/A
2 to 4	1	1
5 to 7	2	2
8 to 10	3	3
11 to 13	4	3
14 to 16	5	3
17 to 19	6	3
20 to 22	7	4
23 to 25	8	4
More than 25	8, plus 1 for each additional 3 over 25, or fraction thereof	5

EXCEPTION: If at least 50% of the elevated play components are connected by a ramp and if at least 3 of the elevated play components connected by the ramp are different types of play components, the above chart shall not apply.
ADASAD 240.2.1.2 Exception

- B.** Where two or more required ground level play components are provided, they shall be dispersed throughout the play area and integrated with other play components.

ADASAD 240.2.1

1. Where a stand-alone slide is provided, an accessible route must connect the base of the stairs at the entry point to the exit point of the slide. Where a sand box is provided, an accessible route must connect to the border of the sand box.

ADASAD 240.2.1 Advisory

Section 28 - Play Areas

- C. At least one turning space complying with Section 0.1 - Accessibility Basics, Part IV shall be provided on the same level as play components.
ADASAD 1008.4.1
- D. A clear floor or ground space complying with Section 0.1 - Accessibility Basics, Part V shall be provided at each play component.
ADASAD 1008.4.2
- E. Where play tables are provided, knee clearance 24" high minimum, 17" deep minimum, and 30" wide minimum shall be provided. The top of table rims, curbs or other obstructions shall be 31" high maximum.
ADASAD 1008.4.3
1. Play tables designed or constructed primarily for children ages 5 and under shall not be required to provide knee clearance if the clear floor or ground space required in Part VIII, Subpart D is arranged for a parallel approach.
ADASAD 1008.4.3 Exception
- F. With the exception of entry points on slides, where play components require transfer to entry points or seats, the entry points or seats shall be 11" minimum and 24" maximum from the clear floor or ground space. Where play components require transfer to entry points or seats, at least one means of support for transferring shall be provided.
ADASAD 1008.4.4-5

Portable Toilets

I. CONCEPT

- A. Portable toilets should only be used as a temporary facility or as a means to provide additional restrooms for special events.

II. GUIDELINES

- A. Where multiple single user portable toilets are clustered at a single location (including for special events and concessions) 5%, but no less than one, of the toilet units at each cluster shall be accessible.

CBC 11B-213.2 Exception 3

- B. Portable toilets shall include a minimum 60" diameter turning space and shall include a minimum 30" wide clear floor space parallel to the toilet to enable a side transfer.

★ Refer to Section 0.1 Accessibility Basics, Part IV Turning Space and Part V Clear Floor or Ground Space.

- C. Accessible portable toilets shall be identified by the International Symbol of Accessibility (ISA).

CBC 11B-213.2 Exception 3

- D. It is Department Policy that a sign with the language "Priority Use for People With Disabilities" shall be attached to the exterior of portable toilets.

☎ Contact the Facilities Management Division Sign Program to order this sign (sign #RS-028C).

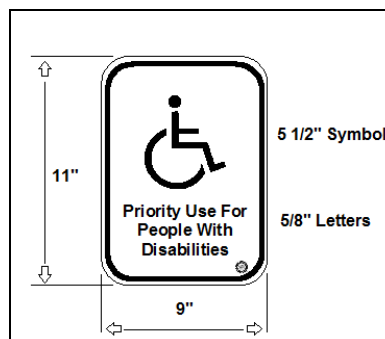



Figure 29-1 Signage for Accessible Portable Toilets

Section 29 - Portable Toilets

- E. Where portable hand washing stations are provided, an accessible portable hand washing station shall also be provided.

 Contact the Accessibility Section for current information pertaining to portable toilets.

Public Telephones

I. CONCEPT

- A. All permanently installed telephones for public use, including pay phones, shall be accessible per this section.
- B. Telephones shall be located on an accessible route of travel.
★ Refer to Section 34 - Routes of Travel.
- C. Where public telephones are provided, wheelchair accessible telephones shall be provided in accordance with **Table 30-1**.

Table 30-1 Number of Accessible Public Telephones

Number of Telephones Provided on a Floor, Level, or Exterior Site	Minimum Number of Required Wheelchair Accessible Telephones
1 or more single units	1 per floor, level, and exterior site
1 bank	1 per floor, level, and exterior site
2 or more banks	1 per bank

II. VOLUME CONTROL

- A. All public telephones, shall be equipped with a volume control adjustable from 12 decibels to 20 decibels.
CBC 11B-704.3
- B. Public telephones with volume control shall be hearing aid compatible and shall be identified by a sign containing a symbol of a telephone handset with radiating sound waves.
CBC 11B-703.7.2.3
★ Refer to Section 36 - Signage for design specifications.

III. WHEELCHAIR ACCESSIBLE TELEPHONES

- A. In addition to a volume control, accessible telephones shall have a cord length of at least 29" and shall have push-button controls where service for such equipment is available.
CBC 11B-704.2.2, 704.2.4

Section 30 - Public Telephones

- B. Telephone controls, including coin slots, shall be located between 15" and 48".
CBC 11B-704.2.2

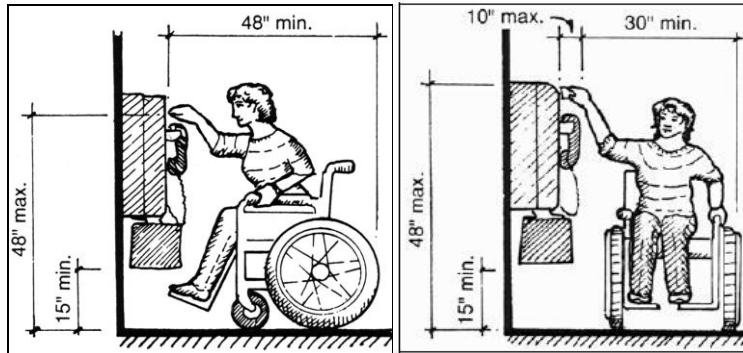

Figure 30-2 Telephone Control Clearances

- C. There must be a clear level space that measures at least 30" x 48" at the front of the telephone for either a forward or side approach.
CBC 11B-704.2.1

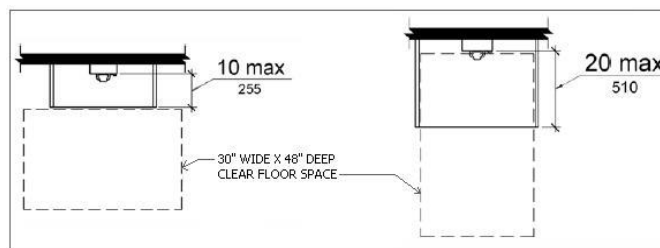

Figure 30-3 Clear Space for a Side or Forward Approach

- D. Where a parallel approach is provided, the distance from the edge of the telephone enclosure to the face of the telephone unit shall be 10" maximum.
CBC 11B-704.2.1.1
- E. Where a forward approach is provided, the distance from the front edge of a counter within the telephone enclosure to the face of the telephone unit shall be 20" maximum.
CBC 11B-704.2.1.2
- F. Where a forward approach is provided at a telephone within an enclosure, the counter may extend beyond the face of the telephone 20" into the required clear floor or ground space and the enclosure may extend beyond the face of the telephone 24". If an additional 6" in width of clear floor space is provided,

Section 30 - Public Telephones

creating a clear floor space of 36" by 48", the enclosure may extend more than 24" beyond the face of the telephone.

CBC 11B-704.2.1.2

IV. TEXT TELEPHONES

- A.** If a total of four or more public pay telephones (including both interior and exterior phones) are provided at a site, and if at least one of the total is in an interior location, then at least one interior public text telephone shall be provided.

CBC 11B-217.4.3-4

- B.** Telephone typewriters (TTY) or text telephones (TT) shall be identified by the International TTY Symbol. Directional signage to the location of the text telephone shall be provided.

CBC 11B-703.7.2.2

★ Refer to Section 36 - Signage for design specifications.

- C.** TTYs provided at a public pay telephone shall be permanently affixed within, or adjacent to, the telephone enclosure. Where an acoustic coupler is used, the telephone cord shall be sufficiently long to allow connection of the TTY and the telephone receiver.

CBC 11B-704.4

- D.** When in use, the touch surface of TTY keypads shall be 34" minimum above the finish floor. EXCEPTION: Where seats are provided, TTYs shall not be required to comply with the 34" minimum.

CBC 11B-704.4.1

- E.** Where a bank of telephones in the interior of a building consists of three or more public pay telephones, at least one public pay telephone in each such bank shall be equipped with a shelf and an electrical outlet within or adjacent to the telephone enclosure. The telephone handset shall be capable of being placed flush on the surface of the shelf. The shelf shall be capable of accommodating a TTY and shall have 6" minimum vertical clearance above the area where the TTY is to be placed.

CBC 11B-704.5

Publications

I. CONCEPT

- A.** All new or reprinted publications shall be prepared using the following guidelines. This policy applies to publications developed at the Headquarters, District or Unit levels, including publications copyrighted to the Department. Staff must ensure that publications produced for the Department by cooperating associations, concessionaires, and other external entities follow these guidelines or subsequent updates.
DOM 2607.3
- B.** The Accessibility Compliance Checklist for Publications may be found in the Appendix. This checklist contains the basic elements necessary for accessible publication design. Refer to this checklist when developing or redesigning publications to ensure that publications are accessible and legally compliant with all statutes and regulations.

II. PUBLICATION DEFINITION

- A.** Publications include but are not limited to brochures, booklets, books, announcements, advertisements, park maps, campground maps, plans, technical reports, teacher materials, and newsletters, as well as electronic versions of such publications.
DOM 2607.3

III. REQUIRED INFORMATION

- A.** Publications must integrate information about accessible features with general descriptive information regarding park sites and facilities.
- B.** The International Symbol of Accessibility (ISA) shall be used to locate accessible features on maps, and may be used to identify the location of accessibility information in publication text.

Section 31 - Publications



Figure 31-1 International Symbol of Accessibility

- C. Publications that include phone numbers must include the following standard statement immediately adjacent to the contact phone number:

“711, TTY RELAY SERVICE.”

- D. Publications that describe park facilities, activities, programs, services, or events shall incorporate the following standard statement:

“CALIFORNIA STATE PARKS SUPPORTS EQUAL ACCESS. PRIOR TO ARRIVAL, VISITORS WITH DISABILITIES WHO NEED ASSISTANCE SHOULD CONTACT [insert contact name and phone number].”

This statement encourages visitors to request assistance, such as a Qualified Sign Language Interpreter (QSLI) for the deaf, in advance.

★ Refer to Departmental Notice 2004-07 for more information on QSLI policy.

- E. All publications shall state:

“THIS PUBLICATION IS AVAILABLE IN ALTERNATE FORMATS BY CONTACTING [insert contact name and phone number].”

Alternate formats for print media include but are not limited to: audio, large font print, electronic format, and Braille.

- F. Printed and electronic advertisements for guided programs and tours shall contain the essential eligibility criteria required to participate in the program or tour.

★ Refer to Section 21 - Guided & Self-Guided Programs and Tours.

Section 31 - Publications

IV. PUBLICATION CONTENT

A. Layout

1. Text must be well balanced with graphics or pictures and empty space. Language used in publications should not be overly wordy or technical. It should be straightforward, relevant, and easy to comprehend for people of all abilities.
2. Words are easier to read in horizontal lines. Artistic word shapes must be kept to a minimum or repeated in linear format, if used.
3. Letter spacing shall be measured between the two closest points of adjacent letters, excluding word spaces. Spacing between individual letters shall be 10% minimum and 35% maximum of font height.

ADASAD 703.5.8

Table 31-1 Measuring Letter Spacing

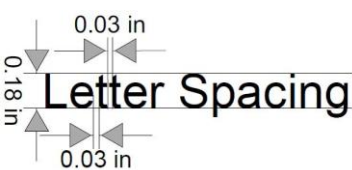
<u>Measurement</u>	<u>Result</u>	<u>Guideline</u>
	$0.03/0.18=0.16 \times 100$ Letter spacing is 16% of font height	Letter spacing shall be 10% minimum to 35% maximum of font height.

4. Spacing between the baselines of sentences within a body of text (leading) shall be 135% minimum and 170% maximum of font height.

ADASAD 703.5.9

Table 31-2 Measuring Leading

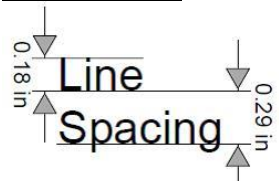
<u>Measurement</u>	<u>Result</u>	<u>Guideline</u>
	$0.29/0.18=1.61 \times 100$ Leading is 161% of font height	Leading shall be 135% minimum to 170% maximum of font height.

5. Maintaining a line length between 45 and 60 characters with margins flush left and ragged right is optimal. Where columns of text are used, space between columns must be large enough so viewers do not read across columns.

Section 31 - Publications

6. Indents should be a standard size. Left indents that force the eye to find a new starting point for each line (such as centered text with very different line lengths, or text wrapped around objects) should be avoided or rarely used.

B. Font

1. Font Family – The font family used for publications shall be legible for persons with varied levels of vision.
 - a. Preferred font families include sans serif fonts. Some examples of sans serif font families include: Arial, Franklin Gothic Book, Lucida Sans, Myriad Pro, Tahoma, and Trebuchet MS.
 - b. Some examples of serif font families that work well include: Adobe Caslon Pro, Bodoni MT, Century Schoolbook, and Garamond.
 - c. The number of font families in a given publication should not exceed two or three.
2. Font Styles – All caps, bold, and italic are difficult to read when used for entire blocks of text. Instead, limit the use of these styles to accent or emphasize important information.
ADASAD 703.5.3
3. Font Proportions - Avoid fonts that are very heavy, very thin, or decorative and those with letters that are either very close together or widely spaced. Font proportions shall meet the following guidelines:
 - a. The width of the uppercase letter “O” shall be 60% minimum and 110% maximum of the height of the uppercase letter “I.”
CBC 11B-703.5.4
 - b. Stroke thickness of the uppercase letter “I” shall be 10% minimum and 20% maximum of the height of the character.
CBC 11B-703.5.7

Section 31 - Publications

Table 31-3 Font Width and Stroke Thickness

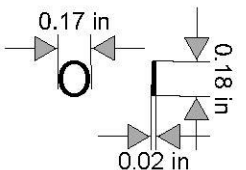
<u>Measurement</u>	<u>Result</u>	<u>Guideline</u>
	<p>width of O is 94% of height of I</p> <p>thickness of I is 11% of height of I</p>	<p>width of O is 60% minimum to 110% maximum of height of I</p> <p>thickness of I is 10% minimum to 20% maximum of height of I</p>

4. Font Height - Minimum font height for publications shall be $\frac{3}{32}$ " or approximately 12-point, measured on the uppercase I.
5. Caption Font Height – Captions which briefly describe images and figures, or provide credits, may be smaller but no smaller than $\frac{1}{16}$ " or approximately 7-point, measured on the uppercase I.

C. Contrast

1. Fonts shall contrast with their background with either dark fonts on a light background or light fonts on a dark background.
ADASAD 703.5.1
2. Placing text over images or patterns forces readers' eyes to constantly adjust to varying contrasts and greatly reduces legibility for those with visual or learning disabilities. Place text over a solid background to achieve the recommended minimum contrast.
3. For printed publications a minimum of 70% contrast between font and background is recommended.
 - a. The scale in the **Figure 31-2** shows shades of gray from 100% (black) to 0% (white) in increments of 10%. Use this chart and the directions that follow to measure contrast of printed material. For measurement purposes, it is best if your publication is printed in black & white or in grayscale.

Section 31 - Publications

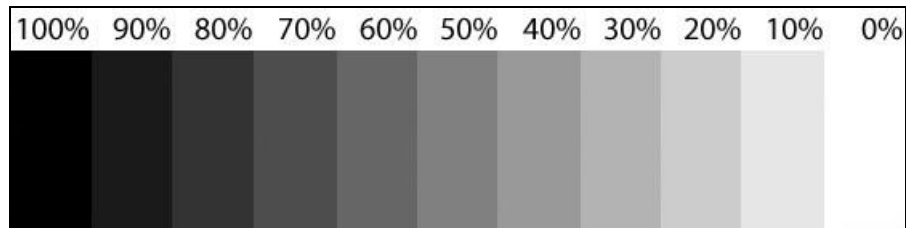

Figure 31-2 Grayscale Chart

b. Directions For Using The Grayscale Chart:

- i. Print this page (in B&W) so you can place the grayscale adjacent to your publication. Find the equivalent gray percentage of your font and background.
- ii. Subtract the lighter of the gray percentage from the darker of the gray percentage to assess whether there is at least 70% contrast between font and background.

★ These directions are a general guide only. Contrast for all published materials should be measured using suitable publishing software.

4. Contrast can be measured on digital/electronic versions of publications by evaluating the relative luminance of the Red, Green, Blue (RGB) values between the font and the background. Ensure a minimum contrast ratio of 4.5:1 (for font smaller than 18-point) by using the World Wide Web Consortium's (W3C) "G18" technique. Several contrast evaluation tools based on their technique are available online or for download.

Visit www.w3.org for more information or ☎ contact the Accessibility Section for assistance.

D. Color

1. When choosing colors for fonts and backgrounds, research suggests that visibility for persons with low vision will be enhanced by considering the following:
 - a. Avoid using red and green against each other as text and background, as persons with red-green color deficiencies (the most common color deficiency) are not able to easily distinguish the two.

Section 31 - Publications

- b. Avoid contrasting colors from adjacent hue families in the color circle (such as orange and yellow, orange and red, yellow and green, blue and green, blue and violet) as they often lack adequate contrasts.
- c. Even if they are from different hue families, colors of similar lightness (such as gray-blue and gray-brown) are difficult for persons with certain color deficiencies to see.
- d. If colors from the same hue families (blue and light blue, brown and tan, etc.) are used adjacent to each other, contrast should be exaggerated to reach the recommended minimum.

V. MAP CONSIDERATIONS

- A. When cartographers create new maps for Department publications, park staff shall recommend that $\frac{3}{32}$ " font (or approximately 12-point measured on the uppercase I) shall be used to label significant features. Campground or trail maps created by field staff, cooperating associations, etc., must also meet or exceed these recommendations and minimums.
- B. Where $\frac{3}{32}$ " font is impractical, select the largest font practical to label significant features.
- C. Minimum font size to label significant features shall be no less than $\frac{1}{16}$ " (or approximately 7-point measured on the uppercase I). Features of lesser significance may be labeled but font does not have to meet minimums.

Table 31-4 Examples of Significant Features

Park Name	Historic Feature
Park Entrance or Kiosk	Campground
Park HQ or Ranger Station	Picnic or Day Use Area
Major Roadway	Beach
City or Town	Trail
Major Body of Water	Accessible Feature
Visitor Center or Museum	Map Legend

- D. Maps that are available electronically shall be cable of up to 500% zoom without pixelation.

Section 31 - Publications

VI. ALTERNATE FORMATS

- A. Upon request, publications must be provided in large print format in a timely manner. Large font electronic versions may suffice, as the requestor wishes.
- B. Large print publications must be 18-point minimum and use a sans serif font.
- C. The responsibility for creating alternate formats lies with the originator of the publication and should be considered a deliverable when planning and designing a publication. Alternate formats for existing publications are the responsibility of the party managing publications in the District or Headquarters.

VII. PUBLICATION REVIEW

- A. Accessible feature information on brochures, trail, and/or campground maps must be reviewed to verify the accuracy of accessible features before being mass produced or posted online. Contact the District Accessibility Coordinator or the Accessibility Section if you are unsure about the information.

VIII. REFERENCES

- A. "Smithsonian Guidelines for Accessible Publication Design". *Smithsonian Institution*, May 2001. Accessed August 2014, <http://www.si.edu/Content/Accessibility/Publication-Guidelines.pdf>
- B. Cooper, Michael et al. "G18: Ensuring that a contrast ratio of at least 4.5:1 exists between text (and images of text) and background behind the text". *Techniques and Failures for Web Content Accessibility Guidelines 2.0. W3C*, 8 April 2014. Accessed August 2014, <http://www.w3.org/TR/WCAG20-TECHS/G18.html>
- C. Arditi, Aries. "Effective Color Contrast". *Lighthouse International*, 2005. Accessed August 2014, <http://www.lighthouse.org/accessibility/design/accessible-print-design/effective-color-contrast>
- D. "Signage and the 2010 ADA Standards v2.1". *Luminant Design LLC*, 2011. Accessed August 2014, <http://www.luminantdesign.com/ada.html>
- E. "Programmatic Accessibility Guidelines for National Park Service Interpretive Media". *Harpers Ferry Center, National Park Service*, February 2012. Accessed August 2014, <http://www.nps.gov/hfc/accessibility/>

Ramps

I. CONCEPT

- A.** Ramps are only used on Accessible Routes of Travel (ART) and Exterior Routes of Travel (ERT). Ramps are not required on Outdoor Recreation Access Routes (ORAR) or trails.
★ Refer to Section 7 - Buildings and Section 34 - Routes of Travel.
- B.** Notwithstanding curb ramps, whenever the slope on an ART or ERT exceeds 5%, a ramp must be provided.
CBC 11B-403.3-4

II. SURFACE

- A.** The surface of the ramp shall be stable, firm and slip resistant.
CBC 11B-405.4
- B.** Changes in level other than the running slope and cross slope are not permitted on ramp runs.
CBC 11B-405.4

III. WIDTH

- A.** Floor or ground surfaces of ramp runs shall firm stable, and slip-resistant. Changes in level other than the running slope and cross slope are not permitted on ramp runs.
CBC 11B-405.4
- B.** All ramps shall have a minimum clear width of 48".
CBC 11B-405.5

Section 32 - Ramps

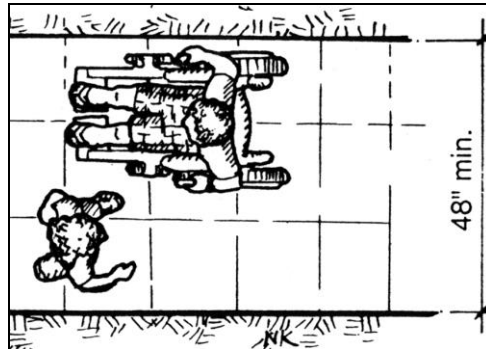

Figure 32-1 Ramp Clear Width

IV. SLOPES

- A. The maximum linear slope on the ramp shall not exceed 8.3%.
CBC 11B-405.2
- B. The maximum cross slope on the ramp shall not exceed 2%.
CBC 11B-405.3
- C. Outdoor ramps and their approaches shall be designed so that water will not accumulate on walking surfaces.
CBC 11B-405.10

V. LANDINGS

- A. Ramps shall have level landings (2% max. gradient) at top, bottom and each change of direction. Intermediate landings shall be provided at intervals not exceeding 30" of vertical rise.
CBC 11B-405.7.1

Section 32 - Ramps

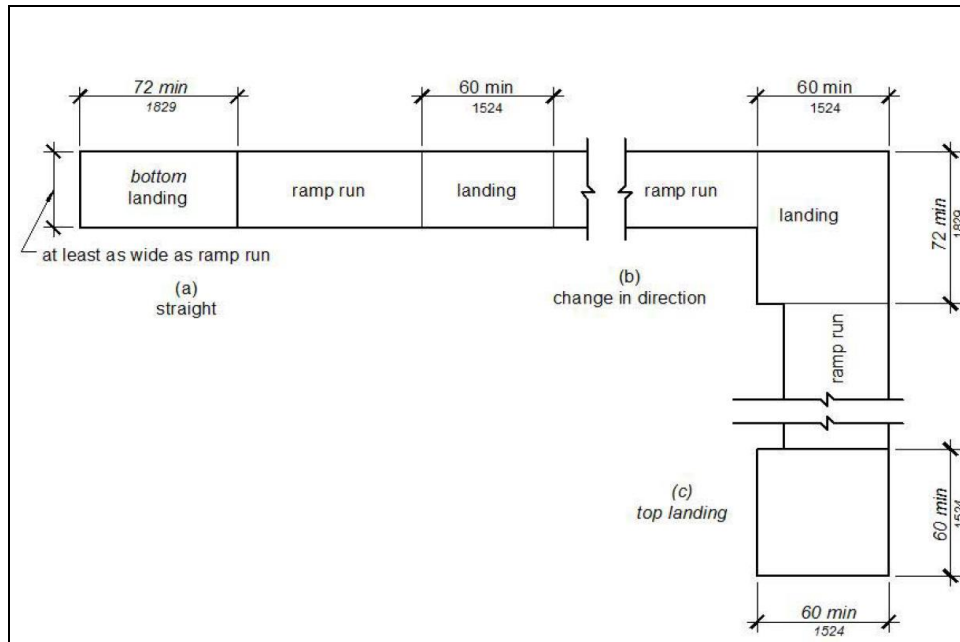

Figure 32-2 Ramp Landings

- B.** Top landings shall not be less than 60" wide and shall have a length of at least 60" in the direction of the ramp run. **(Figure 32-2)**
CBC 11B-405.7.2.1, 407.7.3
- C.** At the bottom and intermediate landings, the width shall be at least the same as the width of the ramp. **(Figure 32-2)**
CBC 11B-405.7.2
- D.** Intermediate landings at a change of direction shall be a minimum of 60" x 72" in the direction of the upper ramp run. Bottom landings shall have a dimension of not less than 72" in the direction of ramp run. **(Figure 32-2)**
CBC 11B-405.7.3.1, 407.7.4
- E.** Where doorways are located adjacent to a ramp landing, maneuvering clearances required by Section 13 - Doors and Gates shall be permitted to overlap the required landing area.
CBC 11B-405.7.5
- F.** The width of the landing shall extend 24" past the strike edge of any door or gate for exterior ramps and 18" past the strike edge for interior ramps.
CBC 11B-404.2.4.3

Section 32 - Ramps

VI. HANDRAILS

- A. Ramp runs shall have handrails that comply with the guidelines specified in Section 22 - Handrails.
CBC 11B-405.8

VII. EDGE PROTECTION

- A. Edge protection shall be provided on each side of ramp runs and at each side of ramp landings that complies with the following:
CBC 11B-405.9.2
1. A curb or barrier, 2" high minimum, which prevents the passage of a 4" diameter sphere, where any portion of the sphere is within 4" of the floor or ground.
 2. To prevent wheel entrapment, the curb or barrier shall provide a continuous and uninterrupted barrier along the length of the ramp.

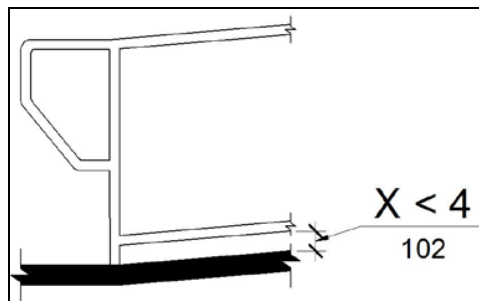

Figure 32-3 Curb or Barrier Edge Protection

3. EXCEPTIONS:
- a. Edge protection shall not be required on ramps that are not required to have handrails and have flared sides that comply with Section 11 - Curb Ramps, Part II, C.
 - b. Edge protection shall not be required on the sides of ramp landings serving an adjoining ramp run or stairway.

Section 32 - Ramps

- c. Edge protection shall not be required on the sides of ramp landings having a vertical drop-off $\frac{1}{2}$ " maximum within 10" horizontally of the minimum landing area.
- B.** Ramps more than 30" above the adjacent ground shall be equipped with guards that comply with *CBC-1013*. Such guards shall be continuous from top to bottom.
CBC 10-1013.2

Restrooms

I. CONCEPT

- A. Access to restrooms shall comply with all subsections of Title 24 of the California Code of Regulations (CCR). The CCR details and specifies all requirements relating to toilets, showers, lavatories, drinking fountains, fixtures and controls.
- B. New restrooms shall be located on an accessible route of travel.
 - ★ Refer to Section 34 - Routes of Travel.
- C. Exterior entry doors shall be accessible.
 - ★ Refer to Section 13 - Doors and Gates.

II. FLOORS

- A. Floor or ground surfaces and slope shall comply with the guidelines outlined in Section 0.1 - Accessibility Basics, Part II Floor and Ground Surfaces and Part III Changes in Level.
- B. The floor or ground must be smooth, hard, and non-absorbent and extend up the walls a minimum of 5”.
- C. Walls within the toilet stalls and walls within 24” of the front and sides of urinals should be smooth, hard, and non-absorbent and finished to 48” above the floor.

III. TOILET STALLS & FIXTURES

A. Toilet Stalls

- 1. Where multiple single user toilet rooms are clustered in a single location (typical unisex restroom building) 50% shall be accessible.
CBC 11B-213.2 Exception 4

Section 33 - Restrooms

2. If six or more stalls are provided in one room, or where the combination of urinals and toilets totals six or more fixtures, at least one toilet stall shall be side transfer and at least one additional ambulatory toilet stall should be at least 60" deep and a width of 35" minimum and 37" maximum, with an outward swinging, self-closing door and have parallel grab bars.

CBC 11B-213.3.1, 604.8.2

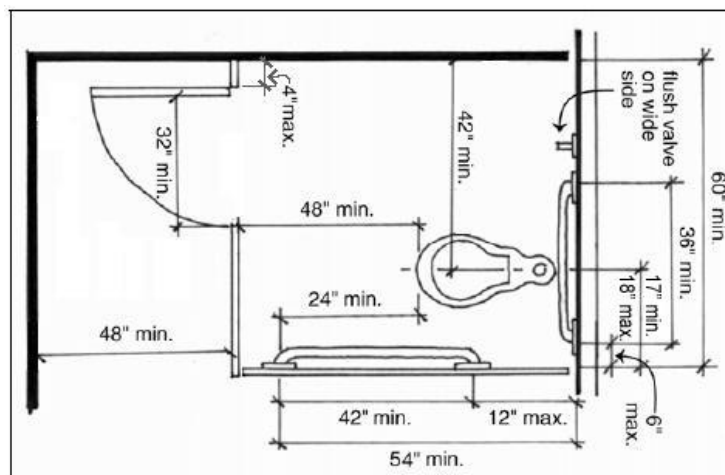

Figure 33-1 Side Transfer Stall (End-Opening)

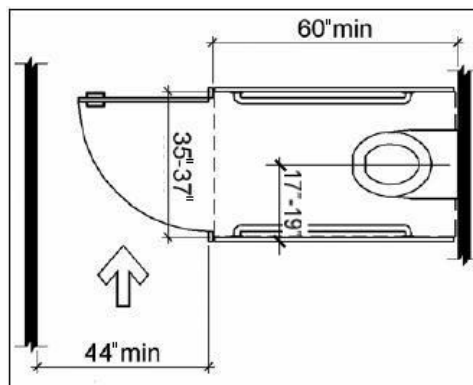

Figure 33-2 Ambulatory Stall

3. The toilet stall shall have a clear, unobstructed opening width of 32" for an end opening stall and 34" for a side opening stall. (Figures 33-1 & 33-3)
CBC 11B-604.8.1.2, 404.2.3

Section 33 - Restrooms

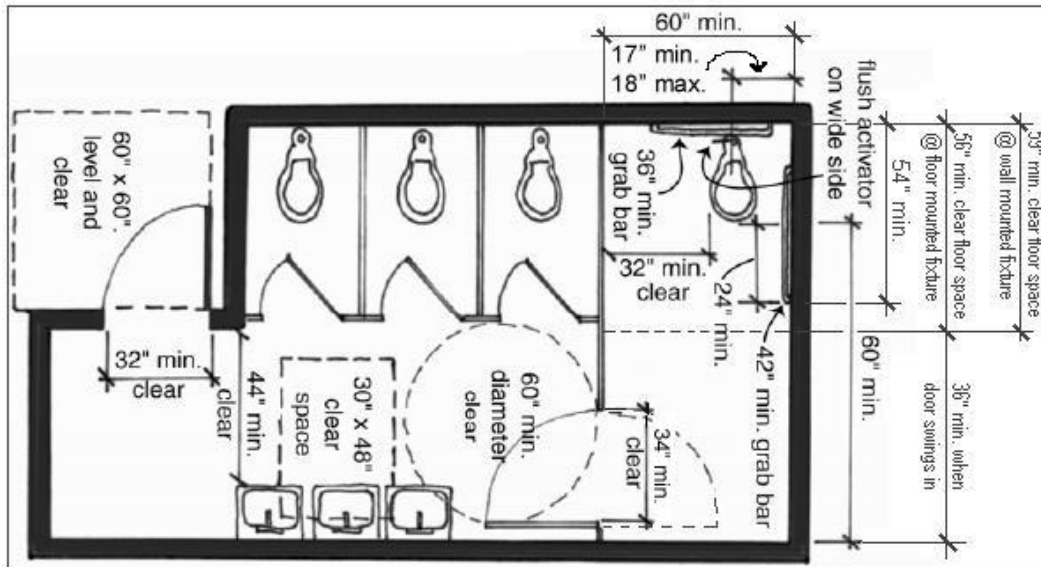

Figure 33-3 Side Transfer Stall (Side-Opening)

4. If there is a common area outside the stalls, a turning space shall be provided measuring 60" in diameter to a height of 27" from the floor. **(Figure 33-3)**
CBC 11B-603.2.1

B. Toilet Stall Doors

1. Other than the door to the accessible toilet compartment, a door in any position may encroach into the turning space by 12" maximum.
CBC 11B-603.2.3
2. Doors shall not swing into the clear floor space or clearance required for any toilet fixture. EXCEPTION: Where the toilet room or bathing room is for individual use and a 30" x 48" clear floor space is provided within the room beyond the arc of the door swing, doors may swing into the clear floor space or clearance required for toilet fixtures.
CBC 11B-603.2.3

Section 33 - Restrooms

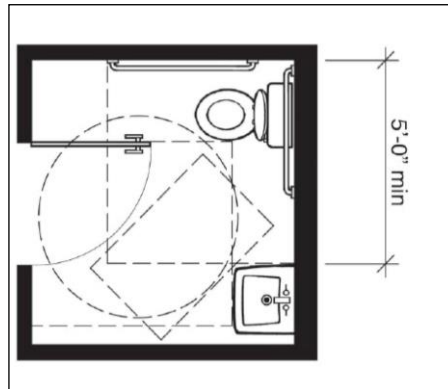

Figure 33-4 Individual Use Toilet Room Door Swing Exception

3. The toilet stall shall be equipped with a self-closing door that can be opened and latched shut with a closed fist.
CBC 11B-604.8.1.2
4. The maximum pressure required to open the stall door must be 5 lbs. or less.
CBC 11B-604.8.1.2, 404.2.9
5. The stall door latch, centered 34" to 48" above the floor, shall be flip-over, sliding or similar style not requiring grasping or twisting.
CBC 11B-604.8.1.2, 404.2.7
6. Toilet compartment doors, including door hardware, shall comply with *Section 13 - Door and Gates*.
CBC 11B-604.8.1.2

C. Toilet Fixtures

1. The toilet fixture shall be positioned with a wall or partition to the rear and to one side. The centerline of the toilet fixture shall be 17" to 18" maximum from the side wall or partition, except that the toilet fixture shall be 17" minimum and 19" maximum from the side wall or partition in the ambulatory accessible toilet compartment. **(Figure 33-1, 33-2, & 33-3)**
CBC 11B-604.2
2. Clearance around a toilet fixture shall be 60" minimum measured perpendicular from the side wall and 56" minimum measured perpendicular

Section 33 - Restrooms

from the rear wall. A minimum 60" wide and 48" deep maneuvering space shall be provided in front of the toilet fixture. **(Figure 33-1 & 33-3)**

CBC 11B-604.3.1

- The height of the top of the toilet seat should be between 17" and 19".

CBC 11B-604.4

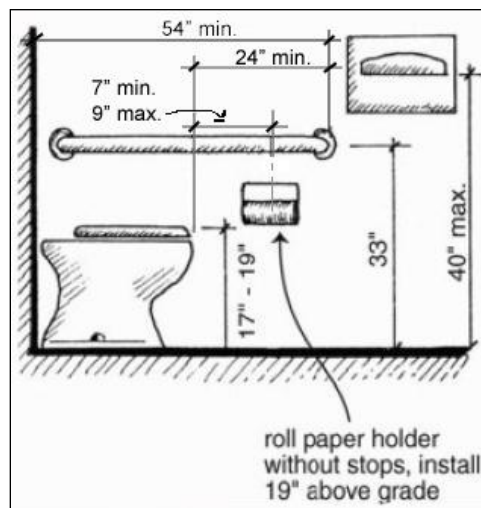

Figure 33-5 Toilet Fixture, Grab Bars and Dispensers

IV. TOILET FIXTURE CONTROLS

- Controls for flush valve shall be mounted on the wide side of toilet areas or urinals 44" or less above the floor.

CBC 11B-604.6

- Controls are well designed if they can be operated with a closed fist.

- Controls and operating mechanisms shall be operable with one hand and not require tight grasping, pinching or twisting.

CBC 11B-309

- Force required to activate controls shall be no greater than 5 lbs.

CBC 11B-309

Section 33 - Restrooms

- E. Lever operated, push-type and electronic controls are preferred control mechanisms.

V. GRAB BARS

- A. Grab bars located on each side, or on one wall and rear wall of a toilet, shall be securely attached, centered 33" above and parallel to the floor (up to 36" for tank type toilets). **(Figure 33-5)**

CBC 11B-604.5, 609.4

- B. Grab bars at the rear wall shall be no less than 36" long (42" is the preferred length).

CBC 11B-604.5.2

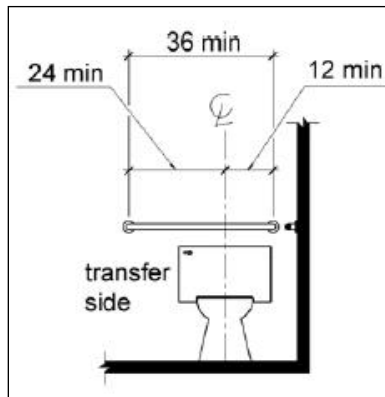

Figure 33-6 Rear Wall Grab Bar

- C. The side wall grab bar shall be 42" long minimum (48" preferred), located 12" maximum from the rear wall and extending 54" minimum from the rear wall with the front end positioned 24" minimum in front of the toilet fixture. **(Figures 33-1 & 33-5)**

CBC 11B-604.5.1

- D. Grab bars shall not rotate in their fittings and shall support a 250 pound load.

CBC 11B-609.6, 609.8

- E. Grab bars with circular cross sections shall have an outside diameter of 1¼" minimum and 2" maximum.

Section 33 - Restrooms

- F. If grab bars are mounted adjacent to a wall, the space between the wall and grab bars shall be 1½".

CBC 11B-609.3

- G. Surface of grab bars shall be free of sharp edges or abrasive elements.

CBC 11B-609.5

VI. DISPENSERS

- A. Toilet paper dispensers shall be installed below the grab bar and shall be 7" minimum and 9" maximum in front of the toilet fixture measured to the centerline of the dispenser outlet, and to a minimum of 19" above the floor.

(Figure 33-5)

CBC 11B-604.7

- B. Dispensers shall not be of a type that controls delivery or that does not allow continuous paper flow.

CBC 11B-604.7

- C. Paper dispensers cannot restrict use of grab bars.

- D. Towel dispensers, air dryers, waste receptacles, coin slots, etc. shall have 30" x 48" level clear space in front and shall be mounted with accessible controls no more than 40" above the floor.

CBC 11B-603.5

- E. Dispensers shall operate with one hand and not require grasping, pinching or twisting.

CBC 11B-309

- F. All levers, dispensers, dryers, etc. must be operable with a maximum pressure of 5 lbs.

CBC 11B-309

Section 33 - Restrooms

VII. URINALS

- A. Where provided, at least one shall have a clear floor space of 30" x 48" in front of the urinal space to allow forward approach.

CBC 11B-605.3

- B. Where provided, at least one shall have a rim projecting a minimum of 13.5" from the wall and a maximum of 17" above the floor.

CBC 11B-605.2

VIII. LAVATORIES

- A. Minimum clear space of 30" x 48" shall be provided in front of the lavatory to allow a forward approach.

CBC 11B-606.2

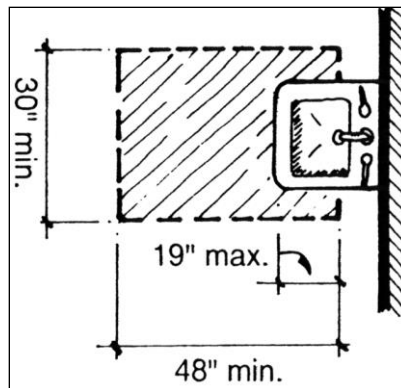

Figure 33-7 Clear Space at Lavatory

- B. Maximum rim height above the floor is 34".

CBC 11B-606.3

Section 33 - Restrooms

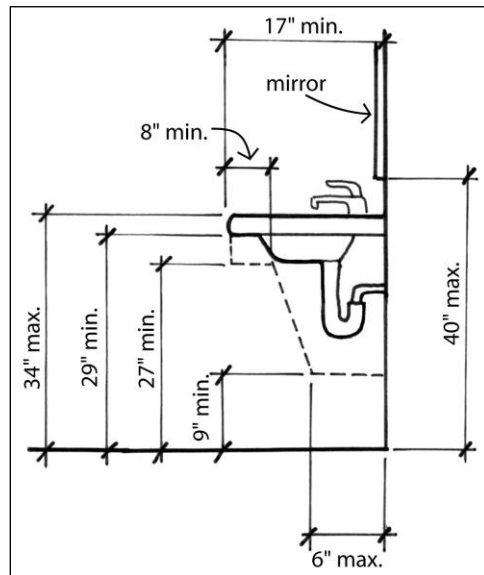

Figure 33-8 Lavatory Maneuvering Clearance

- C. Lavatories shall be mounted with a clearance of at least 27" from the floor to the bottom of the apron. **(Figure 33-8)**
CBC 11B-606.2, 306
- D. Knee clearance and toe clearance is required under lavatories. **(Figure 33-8)**
★ Refer to Section 0.1 - Accessibility Basics, Part VI Knee and Toe Clearance.
- E. The bowl of the lavatory shall be 6½" deep maximum.
CBC 11B 606.7
- F. Hot water lines and drain pipes under lavatories shall be insulated or otherwise covered. There shall be no sharp or abrasive surfaces under the lavatory.
CBC 11B-606.5
- G. If the lavatory is adjacent to a wall, there must be a minimum 18" from the wall to the centerline of the lavatory.
CBC 11B-606.6

Section 33 - Restrooms

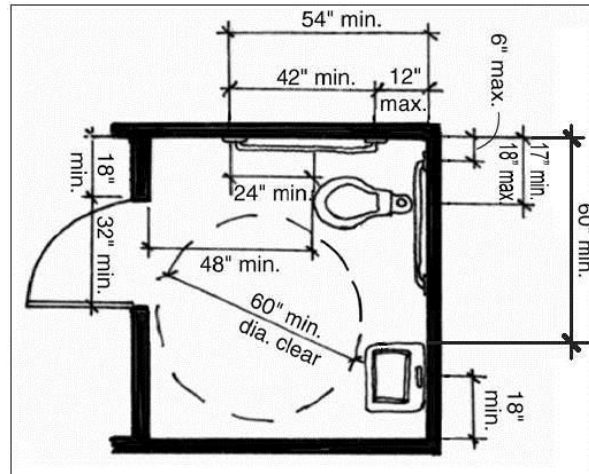

Figure 33-9 Lavatory Wall Clearance

- H. Controls shall comply with Section 0.1 - Accessibility Basics, Part IX Operable Parts.
- I. Faucets may be lever type or self-closing. Self-closing shall remain open for 10 seconds minimum.
CBC 11B-606.4

IX. MIRRORS, CLOTHES HOOKS, AND SHELVES

A. Mirrors

1. Mirrors, if provided, shall be mounted with the bottom edge of the reflecting surface no higher than 40" from the floor. **(Figure 33-8)**
CBC 11B-603.3
2. When mirrors are provided at locations other than above lavatories or countertops, at least one shall be installed with the bottom edge of the reflecting surface 35" (890 mm) maximum above the finish floor or ground.

B. Clothes Hooks

1. If clothes hooks are provided, they shall be within 15" minimum and 48" maximum above the finish floor
CBC 11B-604.8.3, 308

C. Shelves

Section 33 - Restrooms

1. Where provided, shelves shall be located 40" minimum and 48" maximum above the finish floor.

X. LIGHT SWITCHES

- A. Light switches shall be located within compliant reach ranges.
★ Refer to Section 0.1 - Accessibility Basics, Part VIII Reach Range.

XI. SIGNAGE

- A. All restrooms, both single and multi-user, shall be identified by both a visual and a tactile sign installed on the wall adjacent to the latch side of restroom doors. This sign shall comply with the guidelines for visual and tactile signs, height, and location as specified in Section 36 - Signage.

CBC 11B-216.2

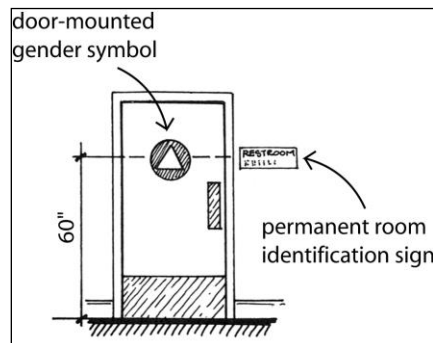

Figure 33-10 Restroom Signage

1. Restrooms that are accessible shall include, on the visual sign, the International Symbol of Accessibility as specified in Section 36 - Signage.
- B. All restroom doors shall be identified by a geometric symbol that complies with the guidelines for symbols specified in Section 36 - Signage.
CBC 11B-216.8
- C. Where existing restrooms are not accessible, visual directional signs indicating the location of the nearest accessible restroom, if any, shall be provided.
 1. Visual signs shall comply with the guidelines found in Section 36 - Signage and shall include the International Symbol of Accessibility.

Routes of Travel

I. CONCEPT

- A.** Routes of travel represent the primary path that a pedestrian would typically use to access a building, facility or activity. In the park setting there are two different types of routes that may be used to connect the elements within a use area. The type of route to use depends upon the level of development in the area and the elements that are being connected. Trails and Beach Access Routes are also used throughout parks, but they are not appropriate routes for use to connect elements within a specific use area.
- ★ Refer to Section 42 - Trails or Section 5 - Beaches and Shores for the technical requirements of Trails or Beach Access routes.
- B.** The most usable route for people with mobility impairments is the Exterior Route of Travel (ERT). The technical requirements for the ERT must be met in highly developed areas, such as paved parking lots to offices, visitor centers, museums and restrooms. Since they are the easiest to use, the grade requirements for the ERT should be met whenever possible in the park setting. The ERT may include: parking access aisles, curb ramps, crosswalks at vehicular ways, walks, ramps and lifts.
- C.** The Outdoor Recreation Access Route (ORAR) is used to connect elements within a camping, picnic, or designated trailhead use area. Typical application of the ORAR is from a campsite to the restroom or campfire center, within a picnic area or between the picnic site and an activity area, such as a trailhead.

II. EXTERIOR ROUTE OF TRAVEL (ERT)

A. General:

1. The accessible route shall be the most practical and direct route possible. It shall incorporate the use of curb ramps, ramps, etc. when necessary.
2. A sign displaying the International Symbol of Accessibility (ISA) at the primary entrance and at every major junction of the accessible route shall be installed. The sign shall be displayed to direct the user to an accessible entrance.

ADASAD 216.6

Section 34 - Routes of Travel

- The slope in the direction of travel shall be a maximum of 5%. Where conditions dictate a slope greater than 5%, a ramp shall be provided.

CBC 11B-403.3

★ Refer to Section 32 - Ramps.

- Walkways with continuous gradients shall have level areas 60" in length at intervals of 400'.

CBC 11B-403.7

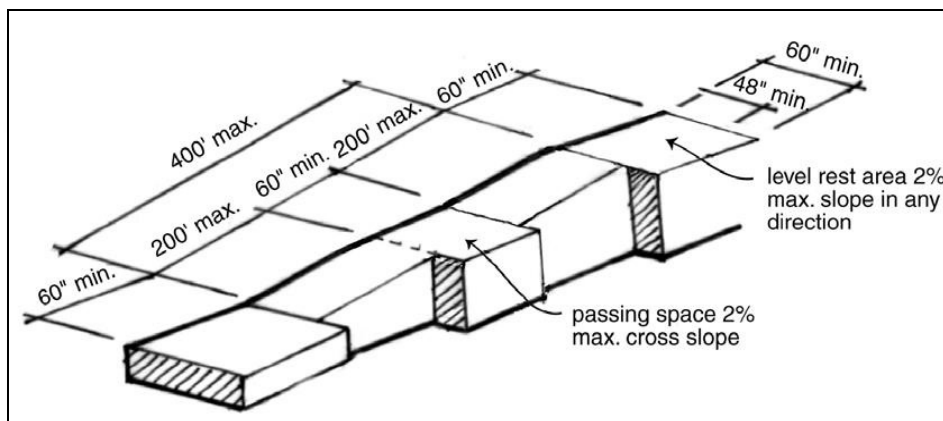

Figure 34-1 Walkways with Continuous Gradient

- Route width shall be a minimum of 48".

CBC 11B-403.5.1

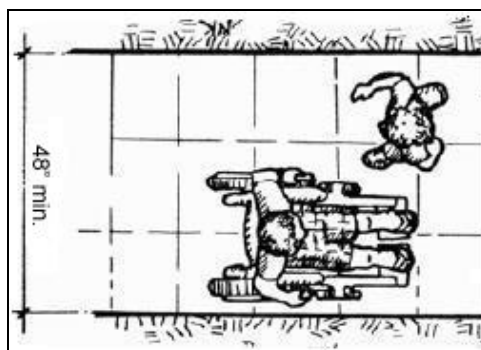

Figure 34-2 Exterior Route of Travel Width

- If an accessible route is less than 60" wide, passing spaces at least 60" x 60" shall be located at maximum intervals of 200'. (Figure 34-1)

CBC 11B-403.5.3

Section 34 - Routes of Travel

7. The slope perpendicular to the direction of travel, cross slope, shall be a maximum of 2%.

CBC 11B-403.3

8. Route surface and change in level shall comply with Section 0.1 - *Accessibility Basics, Part II Floor and Ground Surfaces and Part III Changes in Level.*

B. Details:

1. Where wheelchair traffic is expected to make a U-turn around an obstacle, the route width must be a minimum of 42" on the approach and 48" around the obstacle.

CBC 11B-403.5.2

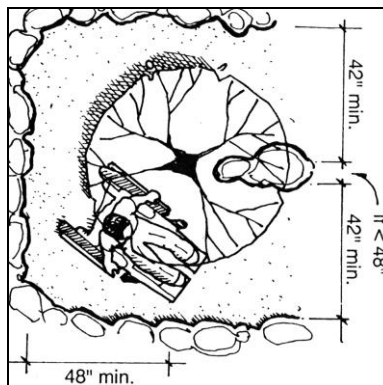

Figure 34-3 U-Turn around an Obstacle (48" wide turn)

2. Where the route is less than 42" (36" minimum), provide 60" around the obstacle.

CBC 11B-403.5.2

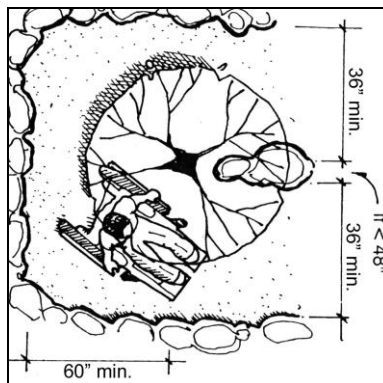

Figure 34-4 U-Turn around an Obstacle (60" wide turn)

Section 34 - Routes of Travel

3. Objects that protrude into the route shall comply with Section 0.1 - Accessibility Basics, Part VII Protruding objects.
4. A level area of at least 60" x 60" shall be provided on the swing side of any door or gate and shall extend 24" to the side of the strike edge. A level area of 48" wide x 44" deep shall be located on the push side of any door or gate.

CBC 11B-404.2.4

★ Refer to Section 13 - Doors and Gates for additional maneuvering clearance requirements at doors and gates.

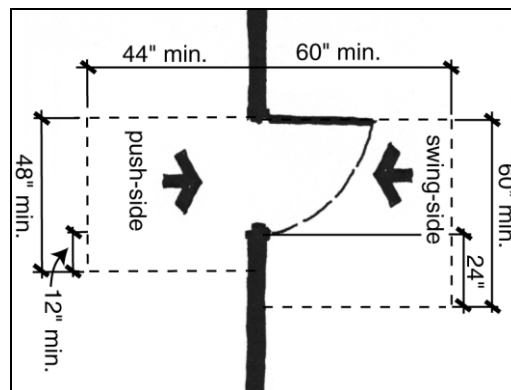

Figure 34-5 Doorway Maneuvering Clearance

III. OUTDOOR RECREATION ACCESS ROUTES (ORAR)

A. General:

1. The surface of the ORAR shall be stable and firm.
AGODA 1016.2
2. Tread obstacles, such as roots or rocks, shall not be higher than 1". Where the surface is concrete, asphalt, or boards, obstacles shall not exceed 1/2" in height measured vertically to the highest point.
AGODA 1016.5
3. The clear tread width shall be 36", except the width may be reduced to 32" for a distance of 24" maximum where existing conditions cannot be mitigated.
ADASAD 403.5.1 Exception 1

Section 34 - Routes of Travel

4. Where the width of the route is less than 60", passing spaces measuring 60" x 60" shall be provided at intervals of 200'.

AGODA 1016.4

5. The running slope and segment length of an ORAR shall comply with **Table 34-1**.

AGODA 1016.7

Table 34-1 Maximum Running Slope and Segment Length

Running Slope of Outdoor Recreation Access Route Segment		Maximum Length of Segment
Steeper than	But not Steeper than	
0%	5%	No Limit
5%	8.33%	50'
8.33%	10%	30'

- a. Running slopes greater than 10% are not permitted.

6. Where the running slope of an ORAR segment is steeper than 5%, a resting space shall be provided at the top and bottom of each segment at intervals per **Table 34-2**. The resting space shall be 60" minimum in length, have a width at least as wide as the route and have a slope of 2% or less in any direction. Where the surface is other than concrete, asphalt, or boards, the slope may exceed 2% but shall not exceed 5% in any direction if required for proper drainage.

AGODA 1016.8

Table 34-2 Resting Space Intervals

Running Slope of Outdoor Recreation Access Route Segment		Resting Space Interval
Steeper than	But not Steeper than	
0%	5%	None Required
5%	8.33%	Every 50'
8.33%	10%	Every 30'

7. The cross slope shall be 2% maximum (where the surface is other than concrete, asphalt, or boards, cross slopes not steeper than 5% shall be permitted when necessary for drainage).

AGODA 1016.7.2

Section 34 - Routes of Travel

B. Details:

1. Openings in the surface of the ORAR, such as on a boardwalk, shall comply with *Section 0.1 - Accessibility Basics, Part II Floor and Ground Surfaces*.
2. Objects that protrude into the ORAR shall comply with *Section 0.1 - Accessibility Basics, Part VII Protruding Objects*.

IV. HANDRAILS

- A.** Where handrails are provided along a route of travel, they shall comply with the guidelines specified in *Section 22 - Handrails*.

Service Machines

I. CONCEPT

- A. Where walk-up service machines (including, ATMs, fee collection, ticket, point of sale machines, and lockers) are provided, they shall be accessibly designed, be on an accessible route of travel, have accessible clear floor space, and follow accessible reach ranges.
- B. All new service machines shall be accessible in accordance with ABA and ADA Accessibility Guidelines for Buildings and Facilities and the California Code of Regulations, Title 24. ☎ Contact the Accessibility Section for assistance.

II. LOCATION

- A. Service machines shall be located on an accessible route of travel.
CBC 11B-206.2.2
★ Refer to Section 34 - Routes of Travel.
- B. One full, unobstructed side of the service machine must adjoin or overlap an accessible route or another clear space.
CBC 11B-206.2.2

III. REACH

- A. Operable parts of the service machine shall be within the prescribed limits for either a forward or side approach as outlined in Section 0.1 - Accessibility Basics, Part VIII Reach Range.
CBC 11B-707.3

Section 35 - Service Machines

IV. ADDITIONAL REQUIREMENTS

- A. Operable parts must be operable with one hand and shall not require tight grasping, pinching, or twisting of the wrist. The force required to activate operable parts shall be 5 lbs. maximum.
CBC 11B-707.3
- B. Machines shall be speech enabled. Operating instructions and orientation, visible transaction prompts, user input verification, error messages, and all displayed information for full use shall be accessible to and independently usable by individuals with vision impairments. Speech shall be delivered through a mechanism that is readily available to all users, including but not limited to, an industry standard connector or a telephone handset. Speech shall be recorded or digitized human, or synthesized.
CBC 11B-707.5
- C. Speech shall be capable of being repeated or interrupted. Volume control shall be provided for the speech function.
CBC 11B-707.5.1
- D. Where receipts are provided, speech output devices shall provide audible balance inquiry information, error messages, and all other information on the printed receipt necessary to complete or verify the transaction.
CBC 11B-707.5.1.2
- E. Numeric keys shall be arranged in a 12-key ascending or descending telephone keypad layout. The number five key shall be tactilely distinct from the other keys.
CBC 11B-707.6.2

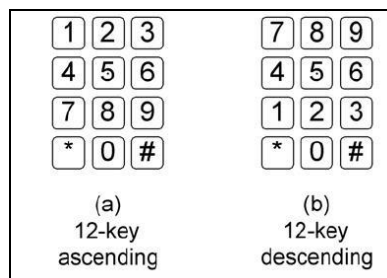

Figure 35-1 Numeric Key Layout

Section 35 - Service Machines

- F.** Function keys shall contrast visually from background surfaces. Characters and symbols on key surfaces shall contrast visually from key surfaces. Visual contrast shall be either light-on-dark or dark-on-light.

CBC 11B-707.6.3.1

- G.** Function key surfaces shall have tactile symbols as follows: Enter or Proceed key: raised circle; Clear or Correct key: raised left arrow; Cancel key: raised letter ex; Add Value key: raised plus sign; Decrease Value key: raised minus sign. *Note: Tactile symbols need not comply with the contrast requirements above.*

CBC 11B-707.6.3.2

- H.** The display screen shall be visible from a point located 40" above the center of the clear floor space in front of the machine.

CBC 11B-707.7.1

1. Where display screens are mounted vertically or no more than 30° tipped away from the viewer, the center line of the display screen and other display devices shall be no more than 52" above the floor or ground surface.

CBC 11B-707.7.1.1

2. Where display screens are mounted between 30° and 60° tipped away from the viewer, the center line of the display screen and other display devices shall be no more than 44" above the floor or ground surface.

CBC 11B-707.7.1.2

3. Where display screens are mounted no less than 60° and no more than 90° (horizontal) tipped away from the viewer, the center line of the display screen and other display devices shall be no more than 34" above the floor or ground surface.

CBC 11B-707.7.1.3

4. Characters displayed on the screen shall be in a sans serif font. Characters shall be 3/16" high minimum based on the uppercase letter "I". Characters shall contrast with their background with either light characters on a dark background or dark characters on a light background.

CBC 11B-707.7.2

- I.** Braille instructions for initiating the speech mode shall be provided.

CBC 11B-707.8

★ Refer to Section 36 - Signage, Part III.

Signage

I. CONCEPT

- A. This section refers to permanent signs installed at or within buildings, day-use areas or campgrounds (including campfire centers), parking lots, and along routes of travel.
- B. There are three general categories of signage that shall comply with this section:
1. Identification signs: Interior and exterior signs that identify permanent spaces and facilities, accessible entrance/exit signs, accessible parking signs, accessible toilet and bathing room signs, and signs indicating availability of an assistive listening system.
★ Refer to Section 26 - Parking for sign guidelines specific to parking.
 2. Location or directional signs: Interior and exterior signs that provide direction to or information about spaces or facilities, availability of and location of facilities (including distances), or availability of and direction to accessible routes.
 - a. Trailhead signage: Exterior signs that provide information about the conditions of a trail.
★ Refer to Section 42 - Trails for sign guidelines specific to trails.
 3. Regulation and safety signs: Interior and exterior signs about rules, procedures and regulations (e.g., restrictive signs such as “NO FISHING, NO CAMPING OR NO SMOKING ON TRAIL”; regulatory sign such as “CAMP IN DESIGNATED AREAS ONLY”; and safety signs such as “UNSAFE DRINKING WATER”).

II. GENERAL

- A. Signs shall be placed in logical and visually unobstructed locations, while ensuring that growth of adjacent foliage will not interfere with visibility.

Section 36 - Signage

- B.** Interior and exterior signs identifying permanent rooms and spaces shall follow the guidelines for both a visual and a tactile sign. Where pictograms are provided as a means of identification, the pictogram shall comply with the guidelines found in this section and shall have a text descriptor with raised characters and Braille that complies with this section.

ADASAD 216.2

1. Where both a visual and tactile sign are required, either one sign with both visual and tactile characters, or two separate signs, one with visual, and one with tactile characters, shall be provided.

ADASAD 703.1

- C.** Interior and exterior signs that provide direction to or information about spaces and facilities shall follow the guidelines for a visual sign.

ADASAD 216.3

- D.** Interior and exterior signs that provide information about rules, procedures, and regulations shall follow the guidelines for a visual sign.

III. TACTILE SIGNS

A. Raised Characters

1. Signs with raised characters shall be duplicated in Braille and shall comply with the following:

ADASAD 703.2

- a. Raised characters shall be $\frac{1}{32}$ " minimum above their background.
- b. Characters shall be uppercase.
- c. Characters shall be sans serif and shall not be italic, oblique, script, highly decorative, or of other unusual forms.
- d. Characters shall be selected from fonts where the width of the uppercase letter "O" is 60% minimum and 110% maximum of the height of the uppercase letter "I."

CBC 11B-703.2.4

Section 36 - Signage

- e. Character height measured vertically from the baseline of the character shall be $\frac{5}{8}$ " minimum and 2" maximum based on the height of the uppercase letter "I."

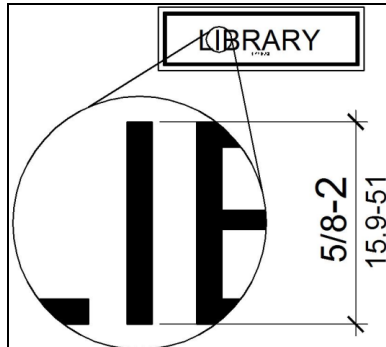

Figure 36-1 Height of Raised Characters

- f. Stroke thickness of the uppercase letter "I" shall be 15% maximum of the height of the character.
- g. Character spacing shall be measured between the two closest points of adjacent raised characters within a message, excluding word spaces. Where characters have rectangular cross sections, spacing between individual raised characters shall be $\frac{1}{8}$ " minimum and 4 times the raised character stroke width maximum. Where characters have other cross sections, spacing between individual raised characters shall be $\frac{1}{16}$ " minimum and 4 times the raised character stroke width maximum at the base of the cross sections, and $\frac{1}{8}$ " minimum and 4 times the raised character stroke width maximum at the top of the cross sections. Characters shall be separated from raised borders and decorative elements $\frac{3}{8}$ " minimum.
- h. Spacing between the baselines of separate lines of raised characters within a message shall be 135% minimum and 170% maximum of the raised character height.
- i. Text shall be in a horizontal format.
CBC 11B-703.2.9

Section 36 - Signage

B. Braille

1. Braille shall be contracted (Grade 2) and shall comply with the following:
 - ADASAD 703.3
 - a. Braille dots shall have a domed or rounded shape and shall comply with **Table 36-1**. The indication of an uppercase letter or letters shall only be used before the first word sentences, proper nouns and names, individual letters of the alphabet, initials, and acronyms.

Table 36-1 Braille Dimensions

Measurement Range	Minimum in Inches to Maximum in Inches
Dot base diameter	0.059" to 0.063"
Distance between two dots in the same cell ¹	0.090" to 0.100"
Distance between corresponding dots in adjacent cells ¹	0.241" to 0.300"
Dot height	0.025" to 0.037"
Distance between corresponding dots from one cell directly below ¹	0.395" to 0.400"

¹Measured center to center

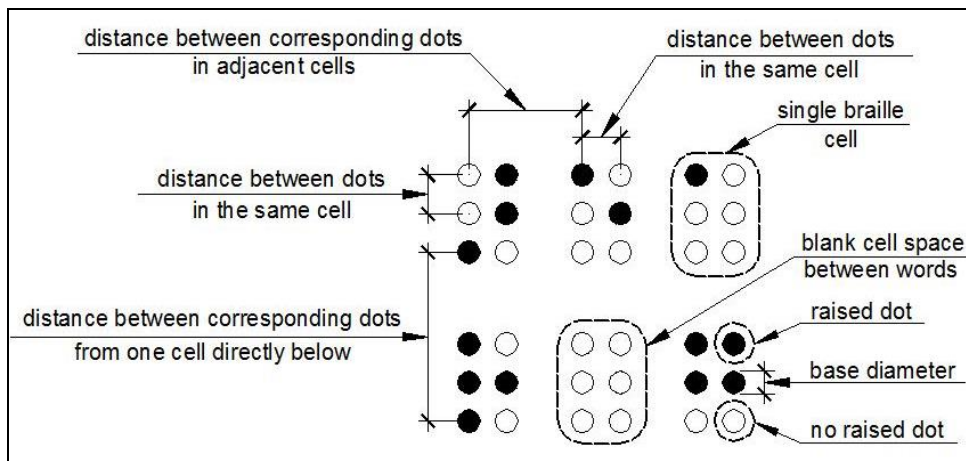

Figure 36-2 Braille Measurement

Section 36 - Signage

- b. Braille shall be positioned below the corresponding text in a horizontal format, flush left or centered. If text is multi-lined, Braille shall be placed below the entire text. Braille shall be separated $\frac{3}{8}$ " minimum and $\frac{1}{2}$ " maximum from any other tactile characters and $\frac{3}{8}$ " minimum from raised borders and decorative elements.

CBC 11B-703.3.2

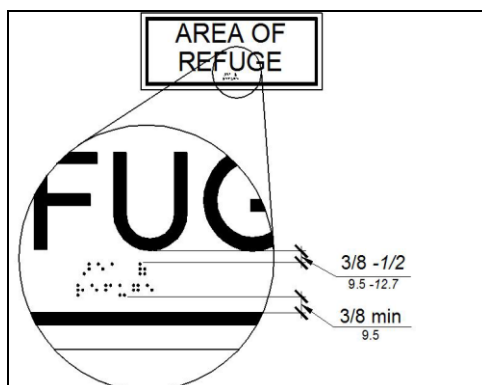

Figure 36-3 Position of Braille

C. Height and Location of Tactile Signs

1. Installation height and location of signs with tactile characters shall comply with the following:

ADASAD 703.4

- a. Tactile characters on signs shall be located 48" minimum above the finish floor or ground surface, measured from the baseline of the lowest Braille cells and 60" maximum above the finish floor or ground surface, measured from the baseline of the highest line of raised characters.

CBC 11B-703.4.1

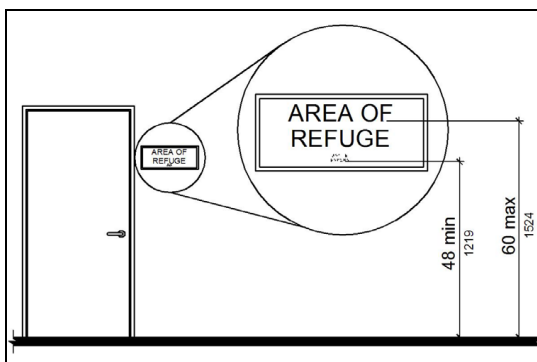

Figure 36-4 Height of Tactile Characters above Finish Floor or Ground

Section 36 - Signage

- b. Where a tactile sign is provided at a door, the sign shall be located alongside the door at the latch side. Where a tactile sign is provided at double doors with one active leaf, the sign shall be located on the inactive leaf. Where a tactile sign is provided at double doors with two active leaves, the sign shall be located to the right of the right hand door. Where there is no wall space at the latch side of a single door or at the right side of double doors, signs shall be located on the nearest adjacent wall. Signs containing tactile characters shall be located so that a clear floor space of 18" minimum by 18" minimum, centered on the tactile characters, is provided beyond the arc of any door swing between the closed position and 45° open position. Where permanent identification signage is provided for rooms and spaces they shall be located on the approach side of the door as one enters the room or space. Signs that identify exits shall be located on the approach side of the door as one exits the room or space.

CBC 11B-703.4.2

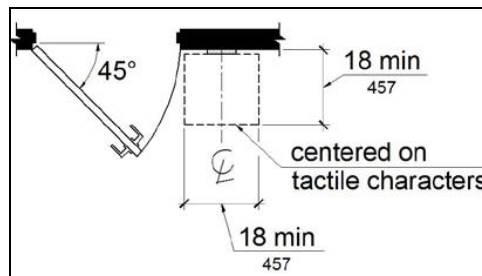

Figure 36-5 Location of Tactile Signs at Doors

IV. VISUAL SIGNS

A. Visual Characters

1. Visual characters on signs shall comply with the following:
ADASAD 703.5
 - a. Exception: Where visual characters comply with the requirements for raised characters and are accompanied by Braille that is compliant, they shall not be required to comply with items b through i.
 - b. Characters and their background shall have a non-glare finish. Characters shall contrast with their background with either light characters on a dark background or dark characters on a light background.
 - ★ Refer to Section 18 - Exhibits for tools to measure contrast.

Section 36 - Signage

- c. Characters shall be uppercase or lowercase or a combination of both.
- d. Characters shall not be italic, oblique, script, highly decorative, or of other unusual forms.
- e. Characters shall be selected from fonts where the width of the uppercase letter "O" is 60% minimum and 110% maximum of the height of the uppercase letter "I."
CBC 11B-703.5.4
- f. Minimum character height shall comply with **Table 36-2**. Viewing distance shall be measured as the horizontal distance between the character and an obstruction preventing further approach towards the sign. Character height shall be based on the uppercase letter "I."

Table 36-2 Visual Character Height

Height to Finish Floor or Ground From Baseline of Character	Horizontal Viewing Distance	Minimum Character Height
40" to less than or equal to 70"	Less than 72"	$\frac{5}{8}$ "
	72" & greater	$\frac{5}{8}$ ", plus $\frac{1}{8}$ " per foot of viewing distance above 72"
Greater than 70" to less than or equal to 120"	Less than 180"	2"
	180" & greater	2", plus $\frac{1}{8}$ " per foot of viewing distance above 180"
Greater than 120"	Less than 21'	3 inches
	21' and greater	3", plus $\frac{1}{8}$ " per foot of viewing distance above 21'

- g. Visual characters shall be 40" minimum above the finish floor or ground.
- h. Stroke thickness of the uppercase letter "I" shall be 10% minimum and 20% maximum of the height of the character.
CBC 11B-703.5.7
- i. Character spacing shall be measured between the two closest points of adjacent characters, excluding word spaces. Spacing between individual characters shall be 10% minimum and 35% maximum of character height.

Section 36 - Signage

- j. Spacing between baselines of separate lines of characters within a message shall be 135% minimum and 170% maximum of the character height.
- k. Text shall be in a horizontal format.
CBC 11B-703.5.10

B. Pictograms

- 1. Pictograms on signs shall comply with the following:
ADASAD 703.6
 - a. Pictograms shall have a field height of 6" minimum. Characters and Braille shall not be located in the pictogram field.

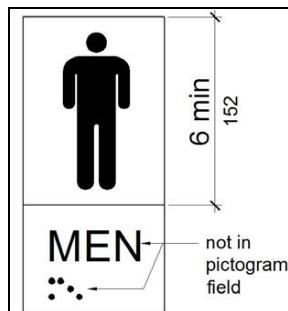

Figure 36-6 Pictogram Field

- b. Pictograms and their field shall have a non-glare finish. Pictograms shall contrast with their field with either a light pictogram on a dark field or a dark pictogram on a light field.
- c. Pictograms shall have text descriptors located directly below the pictogram field. Text descriptors shall comply with the guidelines for raised characters, Braille, height and location.

C. Symbols

- 1. Symbols of accessibility shall comply with the following:
ADASAD 703.7
 - a. Symbols of accessibility and their background shall have a non-glare finish. Symbols of accessibility shall contrast with their background with either a light symbol on a dark background or a dark symbol on a light background.

Section 36 - Signage

- b. The International Symbol of Accessibility shall consist of a white figure on a blue background.



Figure 36-7 International Symbol of Accessibility

- c. International Symbol of TTY.

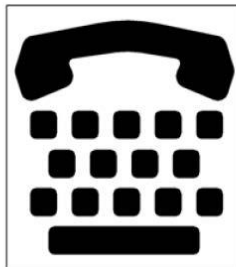

Figure 36-8 International Symbol of TTY

- d. Telephones with a volume control shall be identified by a pictogram of a telephone handset with radiating sound waves on a square field.



Figure 36-9 Volume Control Telephone

- e. Signs for assistive listening systems shall be identified by the International Symbol of Access for Hearing Loss.

Section 36 - Signage



Figure 36-10 International Symbol of Access for Hearing Loss

- f. Signs for audio description shall be identified by the Symbol for Audio Description.



Figure 36-11 Symbol for Audio Description

2. Symbols for restrooms and bathing facilities shall comply with the following:
CBC 11B-703.7.2.6
 - a. Doorways leading to restrooms and bathing facilities shall be identified by a geometric symbol mounted at 58" minimum and 60" maximum above the finish floor or ground surface measured from the centerline of the symbol. Where a door is provided the symbol shall be mounted within 1" of the vertical centerline of the door and shall comply with the following:
 - i. Men's restroom and bathing facilities shall be identified by an equilateral triangle, 1/4" thick with edges 12" long and a vertex pointing upward. The triangle symbol shall contrast with the door, either light on a dark background or dark on a light background.
 - ii. Women's restroom and bathing facilities shall be identified by a circle, 1/4" thick and 12" in diameter. The circle symbol shall contrast with the door, either light on a dark background or dark on a light background.
 - iii. Unisex restroom and bathing facilities shall be identified by a circle, 1/4" thick and 12" in diameter with a 1/4" thick triangle with a vertex pointing upward superimposed on the circle and within the 12" diameter. The triangle symbol shall contrast with the circle symbol, either light on a

Section 36 - Signage

dark background or dark on a light background. The circle symbol shall contrast with the door, either light on a dark background or dark on a light background.

- iv. Edges of signs shall be rounded, chamfered, or eased. Corners of signs shall have a minimum radius of $\frac{1}{8}$ ".

V. REFERENCES

- A. "Audio Description Symbol." *The Audio Description Project, American Council of the Blind*. Accessed November 2014, <http://acb.org/adp/ad.html#what>

Sinks

I. CONCEPT

- A. This section contains the accessibility requirements for sinks other than lavatories or those found in restrooms. These types of sinks include sinks in picnic and campground areas and sinks for utility purposes, such as washing or cleaning fish.

II. STANDARD SINKS

- ★ Refer to Section 33 - Restrooms for lavatory requirements.

III. UTILITY SINKS (DEEP)

- A. Where utility sinks are provided, at least 5%, but not less than one of each type provided, in each accessible room or space shall comply with these guidelines and shall be connected by an Outdoor Recreation Access Route.

99AG 16.13.1

- ★ Refer to Section 34 - Routes of Travel.

- B. A clear floor space of 30" x 48" shall be provided in front of the sink positioned for a parallel approach.

99AG 16.13.2

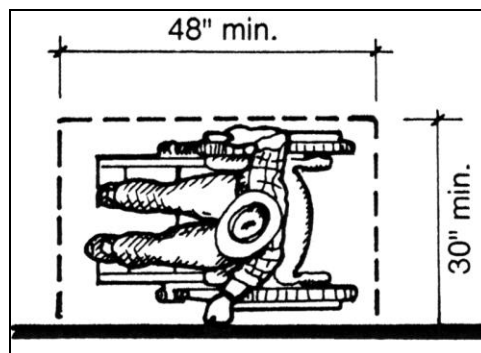

Figure 37-1

Section 37 - Sinks

- C.** The clear space in front of a sink shall have a slope no greater than 2% in any direction. Where necessary for proper drainage, a slope of 3% maximum is allowed.

99AG 16.13.3

- D.** The surface of the clear space shall be stable and firm.

99AG 16.13.4

- E.** The counter or rim of a sink shall be 34" maximum above the floor or ground.

99AG 16.13.5

- F.** The bottom of the sink bowl shall be 15" minimum above the floor or ground.

99AG 16.13.6

- G.** Controls and operating mechanisms shall be within the prescribed reach ranges for an obstructed high side reach and shall comply with the requirements for operable parts.

99AG 16.13.7

★ Refer to Section 0.1 - Accessibility Basics, Part VIII Reach Range and Part IX Operable Parts.

Special Events

I. CONCEPT

- A.** The guidelines in this section refer to park sponsored events held within a park unit that are open to the public, rather than private events such as weddings, receptions, etc.
- B.** Special events often require park staff to allow the public into areas that normally receive little use or that may not be equipped for large groups. Prior to the special event, these areas must be evaluated for accessibility.
- C.** All event facilities must generally be accessible.
- D.** All vendors, concessionaires, etc. associated with the event need to be reminded in advance of their responsibility to provide accessible exhibits, aisles, sales counters, etc.
- E.** The Accessibility Compliance Checklist for Special Events may be found in the Appendix, and contains the basic elements necessary for an accessible event. It is the policy of the Department that special event coordinators utilize the checklist when planning a special event to ensure that it is accessible.

II. GUIDELINES

- A.** Printed and electronic advertisements for special events shall include the required information as specified in *Section 31 - Publications, Part III Required Information*.
- B.** Event parking, including temporary event parking, shall be provided at legally defined ratios of accessible and van accessible spaces to total spaces provided. Slopes, surfaces, routes of travel and signage with the International Symbol of Accessibility (ISA) shall follow the guidelines contained within *Section 26 - Parking and Section 34 - Routes of Travel*.

Section 38 - Special Events

- C.** Event portable toilets, and the route to them, shall follow the guidelines contained within *Section 29 - Portable Toilets* and *Section 34 - Routes of Travel*.
- D.** Event seating, and the route to the seating, shall follow the guidelines contained within *Section 8 - Campfire Centers & Assembly Areas* and *Section 34 - Routes of Travel*.
- E.** Audiovisual programs that may be part of a special event shall follow the guidelines contained in *Section 3 - Audiovisual Programs*.
- F.** An assistive listening system should be considered and used at event assembly areas where audible communication is integral to the use of the space and shall follow the guidelines contained in *Section 2 - Assistive Listening Systems*.
- G.** Guided and self-guided programs and tours that may be part of a special event shall follow the guidelines contained in *Section 21 - Guided & Self-Guided Programs and Tours*.
- H.** Temporary exhibits installed for special events shall follow the guidelines contained in *Section 18 - Exhibits*.
- I.** Temporary visitor information or sales counters installed for special events shall follow the guidelines contained in *Section 43 - Visitor Information & Sales Areas*.

Stairs

I. CONCEPT

- A. Where stairs are provided, in addition to required elevators, lifts or ramps, they shall be on the building/facility route of travel and shall meet the following guidelines.

II. TREADS AND RISERS

- A. The heights and widths of the treads and risers shall be uniform. Risers shall be 4" high minimum and 7" high maximum. Treads shall be 11" deep minimum.
CBC 11B-504.2

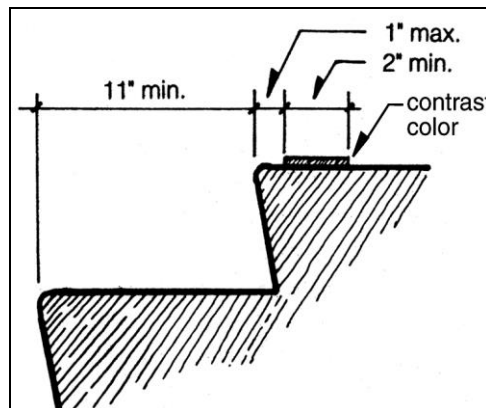

Figure 39-1 Stairway Treads

- B. Open risers are not permitted. EXCEPTIONS: 1. On exterior stairways, an opening of not more than $\frac{1}{2}$ " may be permitted between the base of the riser and the tread, 2. On exterior stairways, risers constructed of grating containing openings of not more than $\frac{1}{2}$ " may be permitted.

CBC 11B-504.3

- C. Tread surface shall comply with the requirements for floor and ground surfaces. Changes in level are not permitted. EXCEPTION: Treads are permitted to have a slope not steeper than 2%.

CBC 11B-504.4

★ Refer to Section 0.1 - Accessibility Basics, Part II Floor and Ground Surfaces.

Section 39 - Stairs

1. Interior stairs shall have the uppermost tread and lowest tread marked by a stripe providing clear visual contrast. Exterior stairs shall have the uppermost tread and all treads marked by a stripe providing clear visual contrast.

CBC 11B-504.4.1

- a. The stripe shall be a minimum of 2" wide to a maximum of 4" wide placed parallel to, and not more than 1" from, the nose of the step or uppermost tread. The stripe shall extend the full width of the step or uppermost tread and shall be of material that is at least as slip resistant as the other treads of the stair. A painted stripe shall be acceptable. Grooves shall not be used to satisfy this requirement. **(Figure 39-1)**

- D. The leading edge of the tread shall have a radius of no more than $\frac{1}{2}$ ". Nosings that project beyond risers shall have the underside of the leading edge curved or beveled. Risers shall be permitted to slope under the tread at an angle of 30° maximum from vertical. The permitted projection of the nosing shall extend $1\frac{1}{4}$ " maximum over the tread below.

CBC 11B-504.5

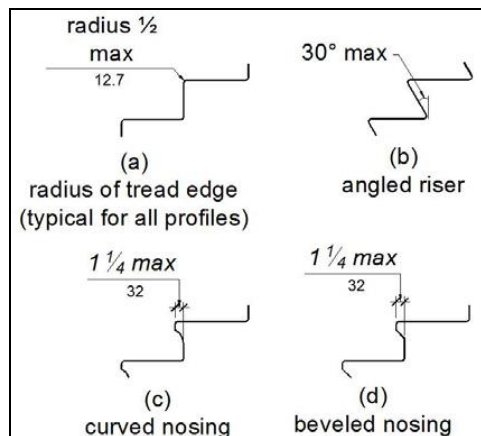

Figure 39-2 Tread Nosings

- E. Stair treads and landings subject to wet conditions shall be designed to prevent accumulation of water.

CBC 11B-504.7

- F. The California Building Code Section 1007.3 shall govern the width of stairs used for a primary exit way.

Section 39 - Stairs

III. HANDRAILS

- A. Stairs shall have handrails that comply with the guidelines specified in *Section 22 - Handrails*.
CBC 11B-504.6

IV. FLOOR IDENTIFICATION

- A. Floor identification signs required by CBC 10-1022.9 shall be located at the landing of each floor level, placed adjacent to the door on the latch side, in all enclosed stairways in buildings two or more stories in height to identify the floor level.
CBC 11B-504.8
- B. The sign shall comply with the requirements for visual and tactile signs found in *Section 36 - Signage*.
- C. At the exit discharge level, the sign shall include a raised five pointed star located to the left of the identifying floor level. The outside diameter of the star shall be the same as the height of the raised characters.
CBC 11B-504.8

Storage Areas & Lockers

I. CONCEPT

- A.** At least 5%, but no less than one of each type of storage facility (cabinets, shelves, closets, drawers, etc.) provided shall be accessible.

CBC 11B-225.2.1

★ Where locker rooms provide dressing areas, refer to Section 15 - Dressing Rooms.

II. DOORWAYS

- A.** The entrance door to storage areas (except shallow closets – those defined as having a reach range of 20” or less) shall have a minimum width opening of 32”.

CBC 11B-404.2.3

- B.** Shallow (not walk-in) closet storage areas shall have a minimum 20” door opening.

CBC 11B-404.2.3(3)

III. APPROACH SPACE

- A.** A clear space immediately adjacent to the storage area /locker shall be a minimum of 30” x 48” and positioned for either a forward or a side approach.

CBC 11B-811.2

- B.** One full, unobstructed closet side shall adjoin or overlap an accessible route or another clear space.

CBC 11B-305.6

Section 40 - Storage Areas & Lockers

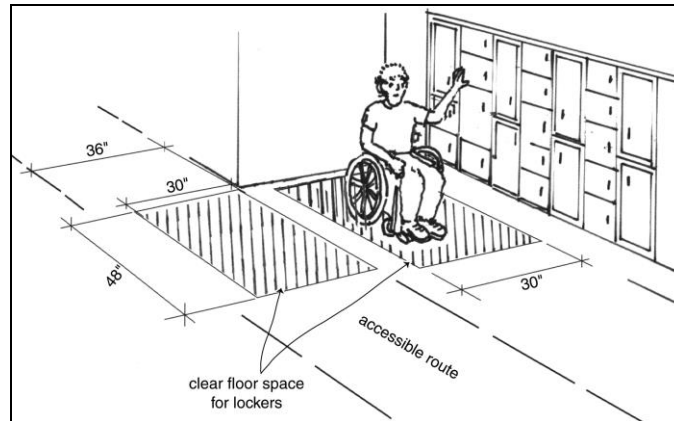

Figure 40-1 Storage Area & Locker Clear Space

- C. Storage areas located in an alcove or confined on all, or part of, three sides shall have additional maneuvering clearances provided.

CBC 11B-305.7

IV. REACHES

- A. Access to the interior of storage areas and lockers shall be within a compliant reach range as specified in Section 0.1 - Accessibility Basics, Part VIII Reach Range.

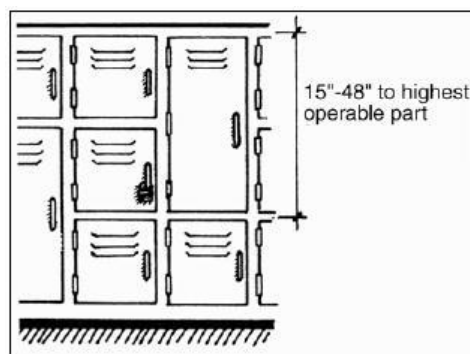

Figure 40-2 Reach Range

V. HARDWARE

- A. Hardware shall be operable with one hand without tight grasping, pinching or twisting and with a force no greater than 5 lbs. Touch latches and u-shaped pulls are acceptable.

CBC 11B-811.4

Swimming Pools

I. CONCEPT

- A. Access to swimming is dependent on getting to the pool area and getting into and out of the water.

II. GENERAL

- A. There shall be an unobstructed path of travel from accessible parking to the swimming pool.
ADASAD 206.2.1
★ Refer to Section 34 - Routes of Travel.
- B. Pool gates shall meet the requirements of Section 13 - Doors and Gates.
- C. Swimming pool deck areas must be accessible and an assistive device must be provided to assist persons with disabilities to enter the pool.

III. SAFETY FEATURES

- A. Float dividers, colors, textures and pavement markings should be used to clearly indicate increasing water depth.
- B. Colors and textures that contrast with the adjoining walking surface should be used to clearly indicate pool and ramp edges and other high-risk areas.
- C. Paving shall be non-slip and non-abrasive.
CBC 31B-3114B.1
- D. Edges of the pool coping should be rounded, with a 1" minimum 2" maximum overhang, and shall not exceed 2½" in thickness.
CBC 31B-3112B.3
- E. There shall be a minimum 48" wide unobstructed path of travel around the pool.
CBC 31B-3114B.1

Section 41 - Swimming Pools

IV. POOL ACCESS

- A. At least two means of entry and exit shall be provided for each swimming pool. The primary means of access shall be a ramp (sloped entry) or lift.

CBC 11B-242.2

1. The secondary means of access shall not duplicate the primary means but may be transfer walls, transfer systems, or stairs.

- B. Swimming pools with a perimeter less than 300 linear feet will have one means of access, which must either be a lift or a ramp (sloped entry).

CBC-11B 242.2 Exception 1

V. POOL ACCESS RAMP

- A. Ramp access into the water shall be an accessible route.

ADASAD 206.2.2

- B. Ramps into swimming pools shall meet the following criteria:

CBC 11B-1009.3

1. Ramps shall meet the requirements of CBC-11B 405 when sloped entry exceeds 5%. The following modifications will be used:
 - a. Ramps shall extend to a depth of 24" minimum to 30" maximum below the stationary water level.
 - b. There shall also be at least one landing located 24" minimum to 30" maximum below the stationary water level.
 - ★ Refer to Section 32 - Ramps.
2. Handrails are required on all ramps.
 - ★ Refer to Section 22 - Handrails.
3. The clear width between handrails must be between 33" and 38".

Section 41 - Swimming Pools

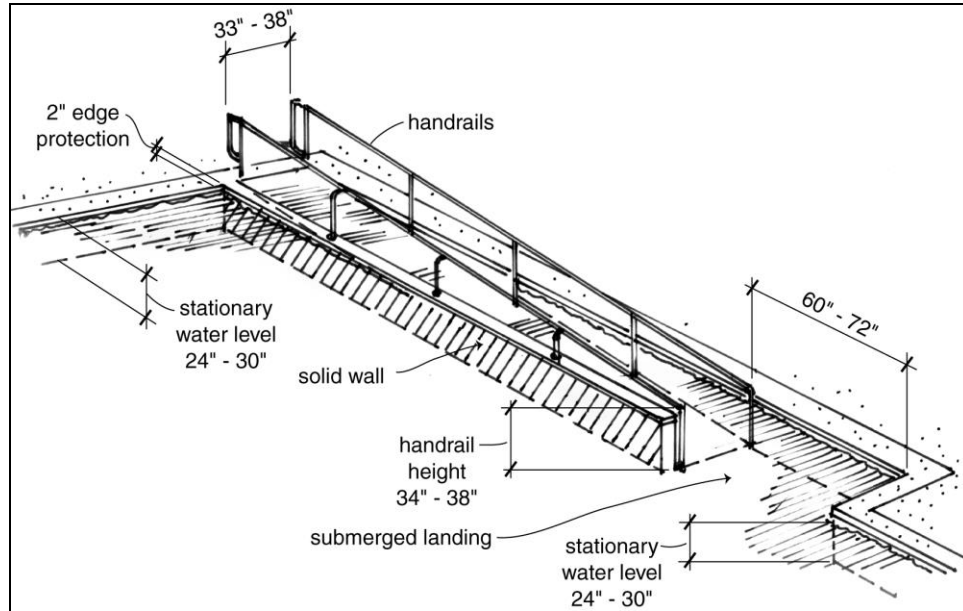

Figure 41-1 Pool Access Ramp

VI. POOL ACCESS LIFT

A. Swimming pool areas must be accessible and a mechanism to assist persons with disabilities in gaining unassisted operation entry into the pool and exiting from the pool shall be provided. Such a mechanism may consist of a swimming pool lift device as long as it meets the following criteria:
CBC 11B-1009.2

1. The seat of the lift shall comply with the following specifications:
 - a. The seat must be rigid and shall have a back support that is 12" tall.
 - b. The seat shall have a restraint for the use of the occupant with operable parts complying with *CBC-11B 309*.
 - c. The lift seat shall be a minimum of 16" wide.
 - d. The seat must have two armrests. The armrest on the side of the seat by which access is gained shall be either removable or fold clear of the seat. Armrests shall not obstruct with the transfer.

Section 41 - Swimming Pools

- e. Footrests shall be provided and move in conjunction with the seat.
- f. The seat shall be capable of unassisted operation from both the deck and water levels. Controls and operating mechanisms shall be unobstructed when the lift is in use and shall comply with *CBC-11B 309.4*.
- g. The seat must be stable and not permit unintended movement when a person is getting into or out of the seat.

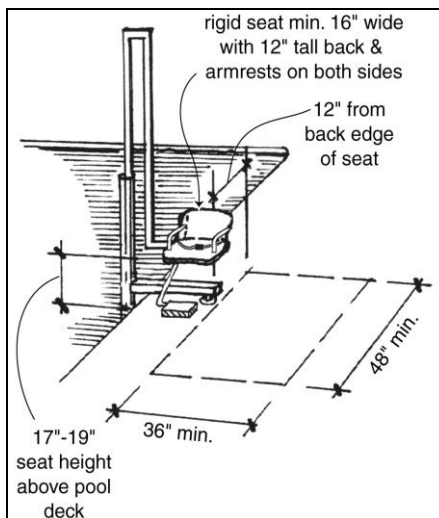

Figure 41-2 Pool Access Lift Seat

- 2. The location of the seat/lift has the following specifications:
 - a. Pool lifts shall be located where the water level is 36" minimum and 48" maximum.
 - b. A minimum clear deck space shall be on the side of the seat opposite the water. The space is measured from the seat. It shall be a minimum of 36" wide and 48" long from a line located 12" behind the rear edge of the seat. The space shall be clear and free of deck braces that can interfere with the transfer. **(Figure 41-2)**
 - c. The height of the lift seat shall be designed to allow a stop at 17" minimum to 19" maximum measured from the deck to the top of the seat surface when in the raised (loaded) position. An adjustable seat may be used. **(Figure 41-2)**

Section 41 - Swimming Pools

- d. In the raised position, the center-line of the lift seat must be located over the pool deck, at least 16" minimum from the edge of the pool.

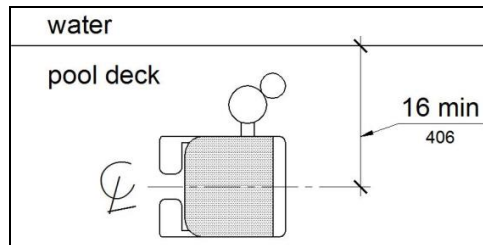

Figure 41-3 Pool Access Lift Seat Location

3. Pool lifts shall be capable of unassisted operation from both the deck and water levels.
- Controls shall be unobstructed when a lift is in use.
 - Controls shall not require tight grasping, pinching or twisting and no more than 5 lbs. of pressure to operate.
 - Pool lift seats shall submerge to a water depth of 18" minimum.

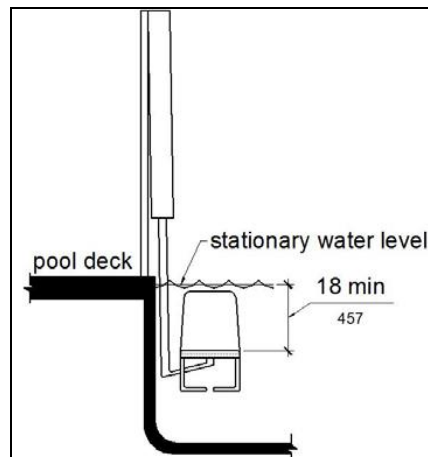

Figure 41-4 Pool Access Lift Submerged Depth

- d. Single pool lifts shall provide a minimum live-load weight capacity of no less than 300 lbs. Lifts shall also be capable of sustaining a static load of at least three times the rated load.

Section 41 - Swimming Pools

VII. STEPS

- A. Pool stairs shall comply with CBC-11B 504.
CBC-11B 1009.6.1
★ Refer to Section 39 - Stairs.
- B. The width between handrails shall be 20" minimum and 24" maximum.
CBC-11B 1009.6.2.
- C. Stair striping in a contrasting color is required on all new pool stairs.
CBC-11B 1009.6.1

VIII. BENCHES

- A. Where fixed benches are provided around the pool deck:
★ Refer to Section 20 - Fixed Benches.

IX. ADDITIONAL CRITERIA

- A. If showers, lockers, drinking fountains or towel racks are provided:
★ Refer to Section 4 - Bathing Facilities, Section 7 - Buildings, Section 16 - Drinking Fountains, and Section 40 - Storage Areas & Lockers.

Trails

I. CONCEPT

- A. Unlike Exterior Routes of Travel (ERT) and Outdoor Recreation Access Routes (ORAR), trails provide the means for the activity of hiking. Trails provide access to remote locations and unique park features. They offer visitors the opportunity to experience various park settings.
- B. Whenever hiking is considered one of the primary activities offered, or where there is a large concentration of trails, every effort should be made to install and maintain accessible trails. The accessible trails should represent the most significant features and environmental experiences unique to the area.
- C. Although addressing accessibility is only required when constructing new trails or making trail alterations, there is always an opportunity to improve access during maintenance management activities (e.g. remove step bridge approach and provide ramped bridge approach during bridge replacement; allow pedestrian passing space through gate along a maintenance road used as a trail route).

II. GUIDELINES

- A. Trail surface.
 - 1. The surface of trails, passing spaces, and resting spaces shall be firm and stable.
AGODA 1017.2
- B. Trail width.
 - 1. The clear width of trails shall be 36" minimum.
AGODA 1017.3
- C. Passing Spaces.
 - 1. Trails with a clear width less than 60" shall provide passing spaces at intervals of 1000' maximum. Where the full length of trail is not accessible, a

Section 42 - Trails

passing space shall be located at the end of the trail segment that is accessible. Passing spaces and resting spaces are permitted to overlap.

AGODA 1017.4

- a. Passing spaces shall either be a space 60" x 60" minimum; or
- b. The intersection of two trails providing a T-shaped turning space, complying with the guidelines in **Section 0.1 - Accessibility Basics**, where the base and the arms of the T-shaped space extend 48" minimum beyond the intersection. Vertical alignment at the intersection of the trails that form the T-shaped space shall be as flat as possible.

D. Trail obstacles.

1. Surface obstacles on trails, passing spaces, and resting intervals, such as roots, rocks, and changes in surface elevations shall not be higher than 2" measured vertically to the highest point. EXCEPTION: Where the surface is asphalt, concrete, or boards, surface obstacles shall not exceed 1/2" in height.

AGODA 1017.5

- a. Where surface obstacles cross the full width of the trail, the obstacles should be separated by a distance of 48" minimum where possible.

E. Trail openings.

1. Openings in the surface, such as on a boardwalk, shall not be greater than 1/2" wide. Elongated openings shall be placed so that the long dimension is perpendicular or diagonal to the dominant direction of travel.

AGODA 1017.6

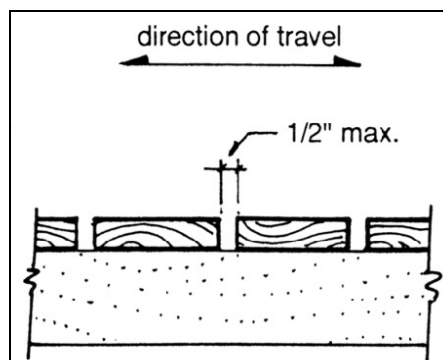

Figure 42-1 Elongated Openings

Section 42 - Trails

F. Running slope.

1. Not more than 30% of the total length of a trail shall have a running slope steeper than 8.33%.
AGODA 1017.7.1
2. The running slope of any segment of a trail shall not be steeper than 12%.
3. Where the running slope of a segment of trail is steeper than 5%, the maximum length of trail shall be in accordance with **Table 42-1** and a resting space complying with part **H** shall be provided at the top and bottom of each segment.

Table 42-1 Maximum Running Slope and Segment Length

Running Slope of Trail		Maximum Length of Trail
Steeper than	But not Steeper than	
0%	5%	None
5%	8.33%	200'
8.33%	10%	30'
10%	12%	10'

G. Cross slope.

1. The slope perpendicular to the direction of travel, cross slope, shall be 2% maximum for concrete, asphalt, or board surfaces and 5% maximum for all other surfaces.
AGODA 1017.7.2

H. Resting Spaces.

1. Resting spaces shall be 60" minimum in length.
AGODA 1017.8.1
2. Where resting spaces are provided within the trail, resting spaces shall be at least as wide as the widest segment of the trail leading to the resting space. Where resting spaces are provided adjacent to the trail, the resting space clear width shall be 36" minimum.
AGODA 1017.8.2

Section 42 - Trails

3. Resting spaces shall have slopes not steeper than 2% in any direction.
EXCEPTION: where the surface is other than concrete, asphalt, or boards, cross slopes not steeper than 5% are permitted when necessary for drainage.

AGODA 1017.8.3

4. Where resting spaces are provided adjacent to the trail a turning spacing, complying with the guidelines in *Section 0.1 - Accessibility Basics*, shall be provided. Vertical alignment between the trail, turning space, and resting space shall be as flat as possible.

I. Protruding objects.

1. Elements on trails, passing spaces, and resting spaces shall be within compliant protrusion limits.

AGODA 1017.9

★ Refer to *Section 0.1 - Accessibility Basics, Part VII Protruding Objects*.

III. GATES

A. Where trails pass through gates:

★ Refer to *Section 13 - Doors and Gates* or ☎ contact the Accessibility Section for alternate gate designs specific to trails.

IV. SIGNAGE

A. Trail signs shall be provided at trailhead access locations and shall include the following information:

AGODA 1017.10

1. Length of trail or trail segment.
2. Surface Type.
3. Typical and minimum trail width.
4. Typical and maximum running slope.
5. Typical and maximum cross slope.

Section 42 - Trails

- B.** Signs with the information in part **A.** are available for order through the Facilities Management Division Sign Program. Fill out the appropriate DPR 93 form and ☎ contact staff in the Sign Program for further assistance.

V. EDUCATIONAL NATURE TRAILS

CBC 11B-246.8

- A.** An educational nature trail is a trail in which the designated use is pedestrian only and is planned for the primary purpose of educating the public on the natural or cultural resources of the area. Educational nature trails also contain a series of informational panels or signs and often a printed informational brochure.
- B.** Educational nature trails shall be made accessible to people with vision disabilities by the provision of tactile edging (such as rope guidelines) or cane detectable edging along at least one side of the trail.
1. This edging should use either elevation change (e.g., raised curb, railing, cut bank back slope, elevated trail) and/or texture change (e.g., transition from concrete to grass, transition from gravel to vegetation, knots in the rope guideline) capable of providing a clearly detectable trail route for cane use.
 2. Distinctive tactile surface textures should call attention to informational displays, panels, site amenities, signs, and related guide and assistance devices. These tactile surface textures should be as wide as the trail and at least 30" long in the direction of travel to ensure sufficient length for detection.
 3. Signs, posts, and panels which are sequentially numbered for the purpose of providing site specific written or audio information shall use raised Arabic numbers and symbols for identification.

★ Refer to Section 18 - Exhibits and Section 36 - Signage for guidelines related to informational panels, raised characters, and symbols.

Visitor Information & Sales Areas

I. CONCEPT

- A. Visitor information and sales areas may be located at entrance stations, visitor centers or museums, or within campgrounds.

II. COUNTERS AND SALES AREAS

- A. Counters/sales areas shall be on an accessible route of travel.
 - ★ Refer to Section 7 - Buildings.
- B. Information counters/sales areas shall have a portion of the counter surface accessible to persons who use wheelchairs.
 - 1. Sales counters and service counters shall comply with item a or item b below. The accessible portion of the counter top shall extend the same depth as the sales or service counter top.
 - a. For parallel approach: A portion of the counter surface that is 36" long minimum and 34" high maximum above the finish floor shall be provided. A 30" x 48" clear floor or ground shall be positioned for a parallel approach adjacent to the 36" inch minimum length of counter.
CBC 11B-904.4.1
 - b. For a forward approach: A portion of the counter surface that is 36" long minimum and 34" high maximum shall be provided. Knee and toe space complying with Section 0.1 - Accessibility Basics shall be provided under the counter. A 30" x 48" clear floor or ground space shall be positioned for a forward approach to the counter.
CBC 11B-904.4.2
- C. Merchandise and sales items shall be placed within one of the compliant reach ranges as specified in Section 0.1 - Accessibility Basics, Part VIII Reach Range.
CBC 11B-308

Section 43 - Visitor Information & Sales Areas

III. CHECKOUT AREA

- A. At least one, but never less than 25% of all service counters with cash registers shall be made accessible by providing a 36" checkout aisle or space on the customer side of the service counter.

CBC 11B-227.2

IV. POINT OF SALE MACHINES

- A. If provided, all point of sale machines, except drive-up, shall meet current accessibility requirements.

★ Refer to Section 35 - *Service Machines*.

V. TURNSTILES

★ Refer to Section 13 - *Doors and Gates*.

Vista Points & Overlooks

I. CONCEPT

- A.** Vista points, roadside pullouts and/or overlooks, their features, views and the experiences they provide, must be accessible.
AGODA F246
- B.** Where multiple viewing areas are provided, at least 20%, but not less than 1 of each viewing opportunity for each distinct point of interest shall be accessible.
AGODA F246.3
- C.** At least one outdoor recreation access route (ORAR) shall connect the accessible parking spaces or other arrival points serving the viewing area with accessible outdoor constructed features, elements, spaces and facilities within the viewing area.
AGODA F246.4

II. VIEWING AREAS

- A.** A clear ground space shall be provided at each distinct viewing location. The clear ground space shall be 36” minimum by 48” minimum and shall be positioned for either a forward or parallel approach to the viewing location. One full unobstructed side of the clear ground space shall adjoin or overlap an ORAR or trail as applicable.
AGODA 1015.2

Section 44 - Vista Points & Overlooks

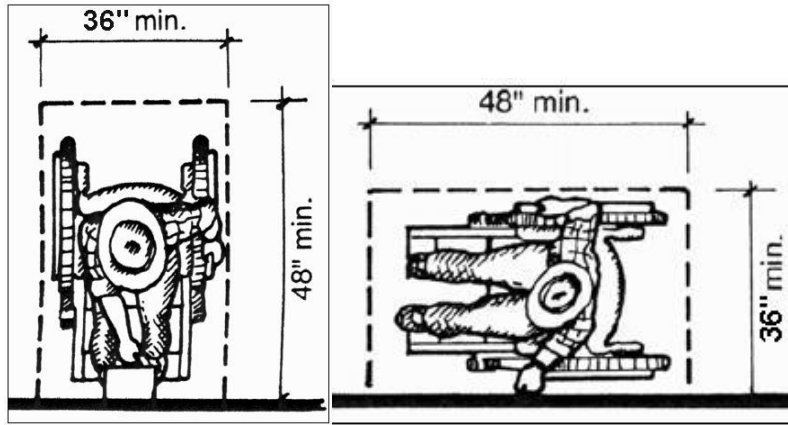

Figure 44-1 Position of Clear Floor or Ground Space

- B. The viewing area shall have at least one circular space 60" in diameter minimum or a T-shaped space at least 36" wide and 60" long on each leg.
AGODA 1015.4

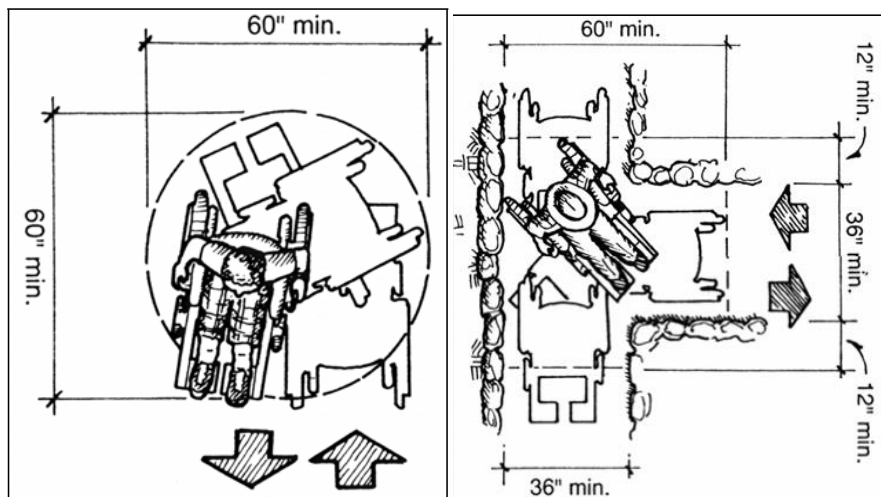

Figure 44-2 Circular Turning Space or T-Shaped Turning Space

- C. The maneuvering space shall be firm, stable and shall not exceed a 2% slope in any direction. Where the surface is other than asphalt, concrete, or boards, a slope not greater than 5% shall be permitted when necessary for drainage.
AGODA 1015.5-1015.6
- D. Each distinct viewing location shall allow unrestricted viewing to accommodate eye levels between 32" and 51" from the ground and shall extend the full width of the clear ground space. EXCEPTION: Guardrails or other safety barriers are

Section 44 - Vista Points & Overlooks

permitted to obstruct the viewing space to the extent the obstruction is necessary for the guard or safety barrier to serve its intended purpose.

AGODA 1015.3

- E. Descriptive signs provided at vista points shall meet appropriate standards.
 - ★ Refer to Section 18 - Exhibits and Section 36 - Signage.
- F. Where feasible, provide audible versions of exhibit information, when exhibits are designed or redesigned.

III. VIEWING SCOPES

- A. Where viewing scopes are provided within viewing areas (e.g. telescopes, periscopes, etc.) at least 20%, but never less than one, of each type shall be accessible.

AGODA 246.3
- B. A clear floor or ground space 36" x 48" shall be positioned for a forward approach to the viewing scope. One full unobstructed side of the clear ground space shall adjoin or overlap an ORAR or trail, or another clear ground space.

AGODA 1011.2.1
- C. Knee and toe clearance shall be provided under the viewing scope.

AGODA 1011.2.1

 - ★ Refer to Section 0.1 - Accessibility Basics, Part VI Knee and Toe Clearance.
- D. Where only one viewing scope is provided, it must be useable from both a seated and a standing position.
- E. The eyepiece of accessible viewing scopes shall be 43" minimum, 51" maximum above the ground.

AGODA 1011.8

Section 44 - Vista Points & Overlooks

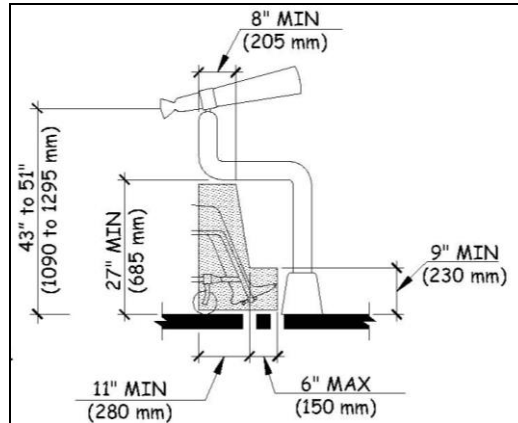

Figure 44-3 Viewing Scope Clearances

- F.** All operating controls shall be operable with one hand, shall not require tight grasping, pinching or twisting, and controls shall not require greater than 5 lbs. of force to activate.

ADASAD 309.4

- G.** All operating controls shall be located within the minimum reach ranges prescribed for a forward approach.

ADASAD 308

★ Refer to Section 0.1 - Accessibility Basics, Part VIII Reach Range.

Work Areas

I. CONCEPT

- A. Spaces and elements within employee work areas shall only be required to comply with CBC 11B-206.2.8, 207.1, and 215.3 and shall be designed and constructed so that individuals with disabilities can approach, enter, and exit the employee work area.

CBC 11B-203.9

- B. Although areas used exclusively by employees for work are not required to be fully accessible, reasonable accommodations shall be made for individuals with disabilities when requested. ☎ Contact the Human Rights Office for work related accommodation issues.

II. GUIDELINES

- A. Common use circulation paths within employee work areas shall be accessible with the following exceptions:

1. Common use circulation paths located within employee work areas that are less than 1000 square feet and defined by permanently installed partitions, counters, casework, or furnishings shall not be required to be accessible.

ADASAD 206.2.8

2. Common use circulation paths located within employee work areas that are an integral component of work area equipment (any machine, instrument, engine, motor, pump, conveyor, etc.) shall not be required to be accessible.

3. Common use circulation paths located within exterior employee work areas that are fully exposed to the weather shall not be required to be accessible.

CBC 11B-206.2.8, 402

- ★ Refer to Section 0.1, Accessibility Basics; and Section 7, Buildings, for more information.

- B. Means of exit shall comply with CBC Chapter 10, Section 1007. Where means of exit are permitted by local building or life safety codes to share a

Section 45 - Work Areas

common path of exit travel, accessible means of exit shall be permitted to share a common path of exit.

CBC-11B 207.1

- C.** Where employee work areas have audible alarm coverage, the wiring system shall be designed so that visible alarms comply with **Section 1 - Alarm Systems**.

CBC-11B 215.3

Glossary

Accessibility Guidelines for Outdoor Developed Areas (AGODA)

Provides scoping and technical specifications for outdoor recreation facilities including camping facilities, picnic facilities, viewing areas, trails, beach access routes, and outdoor constructed features.

Accessible

Admission, passage, circulation, and full use of buildings, facilities, programs, and the various elements within or the combination of them, to persons with disabilities.

Accessible Route

A continuous unobstructed path connecting elements and spaces of a building or facility.

Interior accessible routes may include: corridors, floors, ramps, elevators, lifts, and clear floor space at fixtures.

Exterior accessible routes may include: parking access aisles, curb ramps, crosswalks at vehicular ways, walks, ramps, and lifts.

An accessible circulation path may include an exterior or interior way of passage from one place to another for pedestrians, including, but not limited to, walks, hallways, courtyards, stairways, and stair landings.

Alcove

A small recessed opening off of a larger space.

Alteration

Alter or alteration is any change, addition, or modification in construction or occupancy, or a structural repair or change in primary function to an existing structure other than repair or addition; modifications made to an existing building or facility that go beyond normal maintenance activities and affects or could affect usability.

Glossary

Americans with Disabilities Act of 1990 (ADA)

Federal law that prohibits discrimination against people with disabilities and assures full and equal participation and benefit from the State's programs, services, and activities.

Americans with Disabilities Act Standards for Accessible Design (ADASAD)

Provides scoping and technical specifications for accessibility to new construction and alterations undertaken by Federal, State, and Local entities.

Architectural Barriers Act of 1968 (ABA)

Federal law stating that buildings and facilities designed, constructed, or altered with Federal funds, or leased by a Federal agency, must comply with standards for physical accessibility.

Assembly Areas

A building or facility, or portion thereof, used for the purpose of entertainment, educational or civic gatherings, or similar purposes. For the purposes of these guidelines, assembly areas include, but are not limited to, classrooms, lecture halls, public meeting rooms, campfire centers, visitor centers, auditoriums, theaters, centers for performing arts, amphitheaters, arenas, stadiums, grandstands, or convention centers.

Assistive Device

A device that assists users in accomplishing day-to-day functions. For example, a wheelchair is an assistive device to aid a person who cannot walk.

Assistive Listening System

An amplification system utilizing transmitters, receivers, and coupling devices to bypass the acoustical space between a sound and a listener by means of induction loop, radio frequency, infrared, or direct-wired equipment.

Assistive Technology

Any item, piece of equipment, or system, whether acquired commercially, modified, or customized, that is commonly used to increase, maintain, or improve functional capabilities of individuals with disabilities.

Audio Description

Audio description refers to a specialized type of audio presentation that includes brief explanations of visual items necessary for comprehending content to those who are unable to see them. In a video, audio description may explain movements or appearances of persons or objects, unexplained sounds, facial or body gestures, scenes or setting changes, etc. For tours or exhibits, audio description would provide concise, objective, vivid descriptions of objects, graphics, or other visual elements of the program. Audio description may be live or pre-recorded, and may be delivered by an assistive listening system.

Barrier Removal

Removal, rearrangement, or modification of objects or built elements that impede access.

Beach Access Route

A continuous, unobstructed path that crosses the surface of a beach and provides pedestrians access to the water. Beach access routes may be permanent or removable.

Beach Wheelchair

A wheelchair with large inflated tires that can be used on sandy surfaces.

Bevel

Two surfaces meeting at an angle less than 90°.

Boards

Boards include, but are not limited to, wood, plastic, metal, and composite products.

Braille

A system of writing composed of raised dots in different patterns that represent letters and numbers read with the fingertips.

Buildings

Any and all portions of permanent structures occurring on or in support of a state park unit, including concession buildings, dispatch areas, dormitories, employee housing, entrance kiosks/stations, first aid stations, janitorial rooms, kiosks, laboratories, museums, offices, restrooms, storage areas, theaters, and visitor centers.

Glossary

California Building Code (CBC)

Provides scoping and technical specifications for accessibility to new construction and alterations undertaken by State and Local entities. Parallels the ADASAD and provides additional technical specifications in certain applications.

California Historical Building Code (CHBC)

Provides alternative regulations to facilitate access and use by persons with disabilities to and throughout facilities designated as qualified historical buildings or properties.

Captioned/captioning

The process of converting the audio content of a webcast, film, video, CD-ROM, DVD/Blu-ray, live event, or other production into text and displaying the text on a screen, monitor, or other device. Types of captions include closed captions, open captions, and subtitles for the deaf and hard of hearing.

Circulation Path

An exterior or interior way of passage provided for pedestrian travel, including but not limited to, walks, hallways, courtyards, elevators, platform lifts, ramps, stairways, and landings.

Clear Floor Space

The minimum unobstructed floor space required to accommodate a single, stationary wheelchair and occupant.

Clear Tread Width

The width of the useable surface measured perpendicular to the direction of travel.

Cross Slope

The slope measured perpendicular to the direction of travel.

Decibel (dB)

A unit used to measure the intensity of a sound.

Detectable Warnings

A standardized surface feature built in or applied to walking surfaces or other elements to warn of hazards on a route of travel.

Disability

An individual is defined as having a disability when one or more of the following conditions apply:

- (1) A physical or mental impairment that limits one or more of the major life activities of an individual, or
- (2) A record of such an impairment, or
- (3) Being regarded as having such impairment.

Edge Protection

A curb or wheel-guide rail used to protect an area having a hazardous drop-off.

Educational Nature Trail

A trail in which the designated use is pedestrian only and is planned for the primary purpose of educating the public on the natural or cultural resources of the area; trails usually contain a series of informational panels or signs and a printed informational brochure.

Egress, Means of

A continuous and unobstructed way of exit travel from any point in a building or facility to a public way. An accessible means of egress is one that complies with these guidelines and does not include stairs, steps, or escalators.

Element

An architectural or mechanical component of a building facility, space, or site (e.g., telephone, curb ramp, door, drinking fountain, seating, etc.).

Equivalent Facilitation

The use of designs, products, or technologies as alternatives to the prescribed requirements, that results in substantially equivalent or greater accessibility and usability.

Essential Eligibility Criteria

A set of criteria that defines the very basic or minimum ability level at which a person must be able to perform in order to participate in an activity.

Glossary

Exterior Route of Travel (ERT)

An outdoor route of travel connecting major components of facilities (i.e., parking lot to a building).

Facility

All or any portion of buildings, structures, site improvements, elements, and pedestrian routes or vehicular ways located on a site.

Firm Surface

A surface which resists deformation by either indentations or particles moving on its surface.

Foot-candle (fc)

A unit of illuminance or illumination, equivalent to the illumination produced by a source of one candle at a distance of one foot and equal to one lumen per square foot.

Gangway

A variable-sloped pedestrian walkway that links a fixed structure or land with a floating structure.

Grade

A reference plane representing the average floor or ground level.

International Symbol of Accessibility (ISA)

The symbol adopted by Rehabilitation International's 11th World Congress for the purpose of indicating that buildings and facilities are accessible to persons with disabilities.

Landing

A platform between elevation changes in a route of travel (often used when stairs change direction).

Lavatory

A fixed bowl or basin with running water and drainpipe, as in a toilet or bathing facility, for washing or bathing purposes.

Leading

Blank space between baselines of sentences within a body of text.

Level Area

A surface that does not have a slope in any direction exceeding 2% (1:50) gradient.

Lift

A hoisting and lowering mechanism equipped with a car or platform or support that serves two landings of a building or structure and is designed to carry a passenger or passengers and/or luggage or other material a vertical distance as may be allowed.

Light Reflectance Value (LRV)

The total quantity of visible light reflected by a surface at all wavelengths and directions when illuminated by a light source. The LRV is frequently reported on paint chips and samples.

Nosing

The leading edge of treads of stairs and of landings at the top of stairway flights.

Obstacle

An object that protrudes into the circulation route, limits the vertical passage space, or reduces the clearance width of a pathway. On trails, obstacles can include objects such as boulders and tree branches, or tread obstacles such as tree roots or rocks.

Operable Part

A component of an element used to insert or withdraw objects, or to activate, deactivate, or adjust the element.

Outdoor Constructed Features

Picnic tables, fire rings, grills, fireplaces, wood stoves, trash and recycling receptacles, water hydrants, utility and sewage hookups, outdoor rinsing showers, benches, and viewing scopes provided at outdoor recreation facilities.

Outdoor Recreation Access Route (ORAR)

A continuous, unobstructed path that is intended for pedestrian use that connects accessible elements, spaces, and facilities within camping and picnic facilities and at viewing areas and trailheads.

Glossary

Pictogram

A pictorial symbol that represents activities, facilities, or concepts.

Pixelation

To cause a digital image to break up into pixels by overenlarging it.

Protruding Object

Any object that juts out or projects into an accessible route, outdoor recreation access route, or trail that may cause injury or block access.

Qualified Historic Building or Facility

A building or facility that is listed in or eligible for listing in the National Register of Historic Places, or designated as historic under an appropriate State or local law. See California Code of Regulations Title 24, Part 8.

Qualified Sign Language Interpreter

An interpreter who is able to interpret effectively, accurately, and impartially both receptively and expressively, using any necessary specialized vocabulary.

Quartile

Any of the values in a series dividing the distribution of the individuals in the series into four groups of equal frequency.

Ramp

A walking surface that has a running slope steeper than 5% (1:20).

Reach Ranges

The maximum and minimum height that a person in a wheelchair can reach from either a forward or side approach.

Reasonable Accommodation

Any change or adjustment to a job, the work environment, or the way things usually are done that would allow a person with a disability to apply for a job, perform job functions, or enjoy equal access to benefits available to other individuals in the workplace.

Reasonable Modification

A change in policies, practices, or procedures necessary to afford goods, services, facilities, privileges, advantages, or accommodations to individuals with disabilities.

Rehabilitation Act of 1973, Section 508 Standards

Section 508 establishes requirements for electronic and information technology developed, maintained, procured, or used by the Federal government. Section 508 requires Federal electronic and information technology to be accessible to people with disabilities, including employees and members of the public. California Government Code Section 11135 and the State Administrative Manual, Chapter 4833 require state agencies to adopt the Section 508 Standards.

Rest or Resting Interval

A level portion of a trail that is wide enough to provide wheelchair users and others a place to rest and gain relief from the prevailing grade and cross slope demands of the path.

Riser

The vertical portion of a step in a staircase that connects the top of a tread to the next higher tread.

Route of Travel

An identifiable accessible route within an existing site, building, or facility by means of which a particular area may be approached, entered, and exited, and which connects a particular area with an exterior approach (including sidewalks, streets, and parking areas), an entrance to the facility, and other parts of the facility. When alterations, structural repairs, or additions are made to existing buildings or facilities, the term "route of travel" also includes the toilet and bathing facilities, telephones, drinking fountains, and signs serving the area of work.

Running Slope

The slope that is parallel to the direction of travel.

Sans Serif

A typeface in which characters have no serifs.

Serif

A short line at the ends of the main strokes of a character, which may lead the eye through text, or may make letters run together.

Glossary

Sink

A fixed bowl or basin with running water and drainpipe, as in a kitchen or laundry, for washing dishes, clothing, etc.

Slip-resistant Surface

A surface that provides sufficient frictional counterforce to the forces exerted in walking to permit safe ambulation.

Stable Surface

A surface that remains unchanged by contaminants or applied force, so that when the contaminant or force is removed, the surface returns to its original condition.

Strike Edge Clearance

The clearance from the strike edge of a door to the first protrusion or obstruction.

Tactile

An object that can be perceived using the sense of touch.

Telephone Typewriter (TTY)

Equipment that employs interactive text-based communications through the transmission of coded signals across the standard telephone network. Text telephones can include devices known as TDDs (telecommunication display devices or telecommunication devices for deaf person), computers with special modems, or text telephones (TT).

Title II of the Americans with Disabilities Act of 1990

The section of the Americans with Disabilities Act of 1990 which prohibits state and local governments from discriminating against people with disabilities in programs, services, and activities.

Title 24

A section of the California Code of Regulations, also known as the California Building Code, that, in part, addresses accessibility in buildings and facilities.

Title-safe Area

In television broadcasting, a rectangular area which is far enough in from the four edges of a television screen such that text or graphics show neatly within a margin and without distortion.

Threshold

A strip of wood, metal, or stone along the bottom of a doorway.

Trail

A pedestrian route that is designed, designated, or constructed primarily for outdoor recreational purposes. A pedestrian route developed primarily to connect elements, spaces, or facilities within a site is not a trail.

Trailhead

An outdoor space that is designated by an entity responsible for administering or maintaining a trail to serve as an access point to the trail. The junction of two or more trails or the undeveloped junction of a trail and a road is not a trailhead.

Transcript

A text representation of sounds in an audio clip or an auditory track of a multimedia presentation. A “collated text transcript” for a video combines (collates) caption text with text descriptions of video information (descriptions of the actions, body language, graphics, and scene changes of the visual track). Collated text transcripts are essential for individuals who are deaf-blind and rely on Braille for access to movies and other content.

Transient Lodging

A building or facility containing one or more guest room(s) for sleeping that provides accommodations that are primarily short-term in nature. This does not include residential dwelling units intended to be used as a residence, or private buildings or facilities that contain no more than five rooms for rent or hire and that are actually occupied by the proprietor as the residence of such proprietor.

Transition Plate

A sloping pedestrian walking surface located at the end(s) of a gangway.

Tread

The horizontal part of a step. Also, used to describe the surface of an Outdoor Recreation Access Route.

Truncated Domes

Small domes with cut-off tops that are detectable warnings used at transit platforms, curb ramps, and at the approach to vehicular ways.

Glossary

Turnstile

A post with revolving horizontal bars, placed at an entrance to allow the passage of pedestrians.

Universal Design

The designing of products and environments to be usable by all people, to the greatest extent possible, regardless of age, size, or ability.

Unloading Aisle

The zone adjacent to an accessible parking stall for passenger loading and unloading.

Utility Sink

A sink that has a vertical dimension deeper within the confines of the sink than the standard lavatory basin and allows the user of a picnic area or campground setting to clean large pots or equipment. It has the general configuration of a sink found in a custodial maintenance area.

Vehicular Way

A route provided for vehicular traffic, such as in a street, driveway, or parking facility.

Viewing Area

An outdoor space developed for viewing landscapes, wildlife, or other points of interest.

Vitrine

A glass-paneled cabinet or glass display case for art, objects, artifacts, specimens, curios, etc.

Wing Wall

A wall protrusion at a right angle to another wall.

Appendix

Accessibility Compliance Checklist: Audiovisual Programs

This document is intended to assist those who are designing audiovisual programs. Questions answered "no" indicate the element is not accessible and should be corrected. Refer to Section 3 – Audiovisual Programs for detailed descriptions of accessible requirements. Please ☎ contact the Accessibility Section at (916) 445-8949 or access@parks.ca.gov for clarification or assistance.

I. GENERAL

1. Is the audiovisual program presented in an accessible location?

Yes
 No

2. If requested, has a qualified sign language interpreter been arranged?

Yes
 No
 Not Applicable

3. In public assembly areas where audible communication is integral to the use of the space, an assistive listening system is available?

Yes
 No
 Not Applicable

4. Audiovisual programs part of an exhibit include the requirements for clear floor space, reach range and operable parts where applicable?

Yes
 No
 Not Applicable

II. EQUIPMENT

1. Analog/digital televisions and computer monitors used to transmit the audiovisual program are equipped with caption decoder circuitry?

Yes
 No
 Not Applicable

2. Touchscreens used to transmit an audiovisual program have an input method to connect a keyboard?

Yes
 No
 Not Applicable

Accessibility Compliance Checklist: Audiovisual Programs

3. When part of an exhibit, an audiovisual program with auditory output includes an industry standard connector to allow for private listening?

Yes
 No
 Not Applicable

4. When part of an exhibit, an audiovisual program with voice output includes incremental volume amplification controls?

Yes
 No
 Not Applicable

III. DESIGN

1. ★ Refer to the Accessibility Compliance Checklist for Exhibits for the basics of Audiovisual Program Design.

2. For audiovisual programs transmitted through a TV, monitor, or projector, font size correlates with screen size and the comfortable viewing distance?

Yes
 No
 Not Applicable

3. For audiovisual programs transmitted through a touchscreen, minimum font size is 18-point?

Yes
 No
 Not Applicable

4. Where part of an exhibit, is there a minimum of 10 foot-candles or 10 lumens of light provided to view the audiovisual program?

Yes
 No
 Not Applicable

5. Where held in an indoor or outdoor public assembly area, minimum lighting at floor or ground level is no less than 1 foot-candle or 1 lumen?

Yes
 No
 Not Applicable

6. For interactive audiovisual programs where a timed response is required, users are alerted and given sufficient time to indicate more time is required?

Yes
 No
 Not Applicable

Accessibility Compliance Checklist: Audiovisual Programs

7. Color coding has not been used as the only means of conveying information, indicating an action, prompting a response, or distinguishing a visual element?

Yes
 No
 Not Applicable

8. Where an audiovisual program permits a user to adjust color and contrast settings, a variety of color and contrast settings are available?

Yes
 No
 Not Applicable

9. When transmitted on a TV or monitor, the audiovisual program has been designed to avoid causing the TV or monitor to flicker with a frequency greater than 2Hz and lower than 55Hz?

Yes
 No
 Not Applicable

10. Speech or other audio information necessary for the comprehension of the content of the audiovisual program has been captioned?

Yes
 No
 Not Applicable

11. Visual information necessary for the comprehension of the content of the audiovisual program has been audio described?

Yes
 No
 Not Applicable

IV. OTHER

1. Are alternate formats of audiovisual program content readily available upon request?

Yes
 No

2. Where an assistive listening system is available, has a visual sign been posted in a prominent location indicating the availability of the assistive listening system?

Yes
 No
 Not Applicable

3. Where audio description is available, has a tactile sign been posted in a prominent location indicating the availability of audio description?

Yes
 No
 Not Applicable

Accessibility Compliance Checklist: Exhibits

This document is intended to assist those who are designing exhibits. Questions answered "no" indicate the element is not accessible and should be corrected. Refer to Section 18 – Exhibits for detailed descriptions of accessible exhibit requirements. Please ☎ contact the Accessibility Section at (916) 445-8949 or access@parks.ca.gov for clarification or assistance.

I. EXHIBIT PLACEMENT

1. Has the exhibit been placed along an accessible route?

Yes
 No

2. Has the exhibit been placed adjacent to a 30" x 48" clear floor or ground space for either a forward or parallel approach?

Yes
 No

3. Where an exhibit is mounted greater than 27" to 80" above the floor or ground, no portion of the exhibit protrudes into the accessible route greater than 4"?

Yes
 No
 Not Applicable

4. Where an exhibit is mounted under a roof or shelter, there is 80" minimum clearance from the underside of the roof or shelter to the floor or ground?

Yes
 No
 Not Applicable

II. EXHIBIT CONTENT

1. Is letter spacing 10% minimum to 35% maximum of font height?

Yes
 No
 Not Applicable

2. Is line spacing 135% minimum to 170% maximum of font height?

Yes
 No
 Not Applicable

Accessibility Compliance Checklist: Exhibits

3. For the chosen font is the width of the uppercase letter "O," 60% minimum and 110% maximum the height of the uppercase letter "I?"

Yes
 No
 Not Applicable

4. For the chosen font is the stroke thickness of the uppercase letter "I" 10% minimum and 20% maximum the height of the character?

Yes
 No
 Not Applicable

5. Is the minimum font height $\frac{3}{16}$ " or 18-point?

Yes
 No
 Not Applicable

6. Is there a minimum contrast of 70% or ratio of 3:1 between the chosen font and the background?

Yes
 No
 Not Applicable

7. Is there a minimum of 10 foot-candles or 10 lumens of light provided to view the exhibit?

Yes
 No
 Not Applicable

III. EXHIBIT TYPES

1. Vertical: are graphics and text on the exhibit between 46" and 62" measured from the floor or ground?

Yes
 No
 Not Applicable

2. Angled: is the exhibit placed at a 30° to 60° angle from the floor or ground and 27" minimum to 34" maximum above the floor or ground (measured from the lowest edge)?

Yes
 No
 Not Applicable

3. Table-top: is the top of the exhibit 28" minimum to 34" maximum measured from the floor or ground?

Yes
 No
 Not Applicable

4. Vitrine (top-down view): are objects within the vitrine mounted no higher than 32" measured from the floor or ground?

Yes
 No
 Not Applicable

Accessibility Compliance Checklist: Exhibits

5. Vitrine (eye-level view): are objects within the vitrine mounted no higher than 42" measured from the floor or ground?

Yes
 No
 Not Applicable

6. Exhibits with interactive components and/or controls (including touch screens):

- a. Is there knee and toe clearance under the exhibit that is 27" tall minimum x 30" wide minimum x 19" deep minimum?

Yes
 No
 Not Applicable

- b. Controls on angled exhibits are within 20" from the bottom edge of the exhibit (where the height of the exhibit is 48" maximum from the floor or ground) or within 25" from the bottom edge of the exhibit (where the height of the exhibit is 44" maximum from the floor or ground)?

Yes
 No
 Not Applicable

- c. Controls on table-top exhibits are within 24" from the edge of the exhibit (where the height of the exhibit is 34" maximum from the floor or ground)?

Yes
 No
 Not Applicable

- d. Controls are operable with one hand, do not require tight grasping, pinching, or twisting of the wrist, and require no more than 5 lbs. of force to activate?

Yes
 No
 Not Applicable

7. Audiovisual: ★ Refer to the *Accessibility Compliance Checklist for Audiovisual Programs*.

IV. OTHER

1. Are alternate formats of exhibit content readily available upon request?

Yes
 No

Accessibility Compliance Checklist: Publications

This document is intended to assist those who are planning and designing publications. Questions answered "no" indicate the element is not accessible and should be corrected. Refer to Section 31 –Publications for detailed descriptions of accessible requirements. Please ☎ contact the Accessibility Section at (916) 445-8949 or access@parks.ca.gov for clarification or assistance.

I. REQUIRED INFORMATION

1. Does the publication integrate information about accessible features?

Yes
 No

2. Does the publication state:

“CALIFORNIA STATE PARKS SUPPORTS EQUAL ACCESS. PRIOR TO ARRIVAL, VISITORS WITH DISABILITIES WHO NEED ASSISTANCE SHOULD CONTACT [insert contact name and phone number]”

Yes
 No

3. Immediately adjacent to a contact phone number, does the publication state:

“711, TTY RELAY SERVICE.”

Yes
 No

4. Does the publication state:

“THIS PUBLICATION IS AVAILABLE IN ALTERNATE FORMATS BY CONTACTING [insert contact name and phone number].”

Yes
 No

5. Printed and electronic advertisements for guided programs and tours contain the essential eligibility criteria to participate in the program or tour?

Yes
 No
 Not Applicable

II. PUBLICATION CONTENT

1. Is letter spacing 10% minimum to 35% maximum of font height?

Yes
 No

Accessibility Compliance Checklist: Publications

2. Is line spacing 135% minimum to 170% maximum of font height?

Yes
 No

3. For the chosen font is the width of the uppercase letter "O," 60% minimum and 110% maximum the height of the uppercase letter "I"?

Yes
 No

4. For the chosen font is the stroke thickness of the uppercase letter "I" 10% minimum and 20% maximum the height of the character?

Yes
 No

5. Is the minimum font height $\frac{3}{32}$ " or 12-point?

Yes
 No

6. Is there a minimum contrast of 70% or ratio of 3:1 between the chosen font and the background?

Yes
 No

III. MAPS

1. Has the International Symbol of Accessibility been used to locate accessible features on maps?

Yes
 No

2. Is the minimum font height to label significant features on the map $\frac{1}{16}$ " or 7-point?

Yes
 No

3. Are maps that are available electronically capable of up to 500% zoom without pixelation?

Yes
 No
 Not Applicable

IV. OTHER

1. Are alternate formats of publication and map content readily available upon request?

Yes
 No

Accessibility Compliance Checklist: Special Events

This document is intended to assist those who are planning a park sponsored special event that is open to the public. Questions answered "no" indicate the element is not accessible and should be corrected. Refer to Section 38 – Special Events for detailed descriptions of accessible requirements. Please ☎ contact the Accessibility Section at (916) 445-8949 or access@parks.ca.gov for clarification or assistance.

NOTE: For event publications and events with exhibits and/or audio-visual programs, refer to the corresponding checklist. Review all relevant chapters within the guidelines for any items not covered in this checklist.

I. EVENT PARKING

1. The ratio of accessible parking spaces to total spaces has been provided per Section 26 - Parking?

Yes
 No

2. The slope of accessible parking is not >2% in any direction?

Yes
 No

3. Accessible parking stalls are 18' deep minimum, 9' wide minimum, and have a 5' wide minimum aisle (8' minimum aisle if van accessible)?

Yes
 No

4. Accessible parking stalls are identified with the International Symbol of Accessibility?

Yes
 No

II. RESTROOMS

1. Where multiple single user portable toilets are clustered at a single location 5%, but not less than one, are accessible?

Yes
 No
 Not Applicable

2. Portable accessible toilets include a minimum 60" diameter turning space and a minimum 30" wide clear floor space parallel to the toilet to enable a side transfer?

Yes
 No
 Not Applicable

Accessibility Compliance Checklist: Special Events

3. Are portable accessible toilets identified by the International Symbol of Accessibility and a sign that states "Priority Use for People With Disabilities?"

- Yes
 No
 Not Applicable

4. Where portable hand washing stations are provided, is there an accessible portable hand washing station?

- Yes
 No
 Not Applicable

III. ROUTES OF TRAVEL

1. Intended routes of travel from parking to the event, restrooms, seating, food booths, etc., meet either the requirements for an ERT or an ORAR (depending on event location) per Section 34 - Routes of Travel?

- Yes
 No

IV. ASSEMBLY AREAS

1. The ratio of accessible seating to total seating has been provided per Section 8 - Campfire Centers & Assembly Areas?

- Yes
 No
 Not Applicable

2. Where there are >300 seats, accessible seating has been distributed throughout the area to provide a choice of sight lines?

- Yes
 No
 Not Applicable

3. Accessible seating spaces are 33" wide minimum where two adjacent spaces are provided or 36" wide minimum where a single space is provided?

- Yes
 No
 Not Applicable

4. Accessible seating spaces are 48" deep minimum for a front or rear approach or 60" deep minimum for a side approach?

- Yes
 No
 Not Applicable

Accessibility Compliance Checklist: Special Events

5. Where provided, stages and other spaces used by presenters are connected to accessible seating by an accessible route?

Yes
 No
 Not Applicable

6. Where audible communication is integral to the event, is an assistive listening system available?

Yes
 No
 Not Applicable

7. If requested, or if a significant part of the event is a group presentation, will a qualified sign language interpreter be provided?

Yes
 No
 Not Applicable

V. VISITOR INFORMATION AND/OR SALES AREA

1. Are information/sales counters 28" high minimum to 34" high maximum, with a section that is 36" long minimum?

Yes
 No
 Not Applicable

2. Is there a 30" x 48" clear floor or ground space adjacent to the accessible portion of the counter that is positioned for either a forward or parallel approach?

Yes
 No
 Not Applicable

3. Reaches to brochures, books, souvenirs, etc. are within one of the six reach ranges per Section 0.1 – Accessibility Basics?

Yes
 No
 Not Applicable

4. At least 25% of all checkout areas have aisles at least 36" wide?

Yes
 No
 Not Applicable

5. If these standards cannot be met, is a sign posted stating, "If you need assistance, please ask?"

Yes
 No
 Not Applicable

